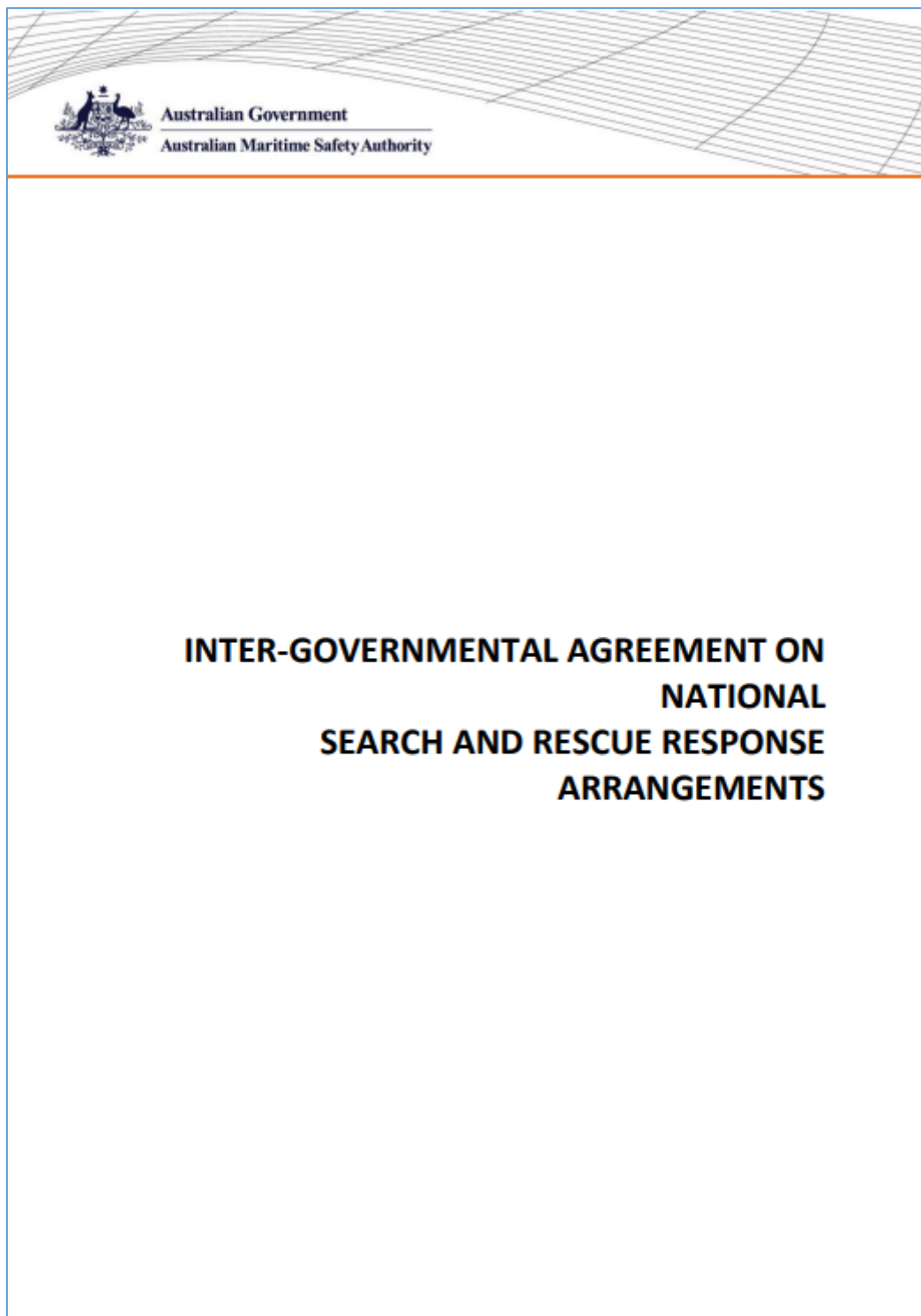

Appendices

NATIONAL SEARCH AND RESCUE MANUAL

2025 EDITION Version 1 – February 2025

Appendix A – Intergovernmental Agreement

This appendix contains a copy of the 2017 IGA applicable to the Australian National SAR Plan.



INTER-GOVERNMENTAL AGREEMENT ON NATIONAL SEARCH AND RESCUE RESPONSE ARRANGEMENTS

This AGREEMENT is made in November 2017.

BETWEEN

THE COMMONWEALTH OF AUSTRALIA
THE STATE OF NEW SOUTH WALES
THE STATE OF VICTORIA
THE STATE OF QUEENSLAND
THE STATE OF WESTERN AUSTRALIA
THE STATE OF SOUTH AUSTRALIA
THE STATE OF TASMANIA
THE NORTHERN TERRITORY OF AUSTRALIA
THE AUSTRALIAN CAPITAL TERRITORY
(‘The Parties’)

1. DEFINITIONS

- 1.1 **‘Alerting Post’** means any facility serving as an intermediary receiving distress alerts and then responsible for onward distribution to the responsible SAR Authority.
- 1.2 **‘AMSA’** means the Australian Maritime Safety Authority.
- 1.3 **‘Australian SAR Authority’** means the authority with international responsibility for compliance with Australia’s search and rescue obligations, being AMSA.
- 1.4 **‘International distress alert’** means an internationally recognised distress alert or signal with location data, if available.
- 1.5 **‘National Search and Rescue Response Arrangements’** means this agreement.
- 1.6 **‘National SAR Council’** means the National Search and Rescue Council as constituted in accordance with paragraph 3.1 of this agreement.
- 1.7 **‘National SAR Manual’** means the National Search and Rescue Manual endorsed by the National SAR Council as the standard reference to be used by all search and rescue authorities in Australia for search and rescue operations.
- 1.8 **‘SAR’** means search and rescue.

2

- 1.9 **'SAR Facility'** means any mobile resource, including designated search and rescue units, used to conduct search and rescue operations.
- 1.10 **'State and Territory SAR Authorities'** means the following agencies nominated by each Party to this agreement:
- The New South Wales Police for the State of New South Wales;
 - The Victoria Police for the State of Victoria;
 - The Queensland Police for the State of Queensland;
 - The Western Australia Police for the State of Western Australia;
 - The South Australia Police for the State of South Australia;
 - The Tasmania Police for the State of Tasmania;
 - The Northern Territory Police for the Northern Territory;
 - The Australian Federal Police for the Australian Capital Territory including Jervis Bay; and
 - The Australian Federal Police for the territories of Christmas Island, Cocos (Keeling) Islands, and Norfolk Island.
- 1.11 **'State/Territory Emergency Service Agencies'** means the agencies that have responsibility for providing State/Territory emergency services as legislated within each State/Territory, which provide support to the national SAR arrangements.
- 1.12 **'Vessels'** and **'craft'** do not include vessels and craft of the Australian Defence Force or those of the defence force of any other country.

2. PURPOSE OF THE AGREEMENT

- 2.1 This agreement is intended to provide guidance to the SAR Authorities of all Parties, recognising that:
- 2.1.1 This Agreement updates and replaces the Agreement signed 29 June 2012;
- 2.1.2 AMSA, established under the Australian Maritime Safety Authority Act 1990 as a Commonwealth statutory authority, has as a legislative function the provision of a national search and rescue service in a manner consistent with Australia's obligations under the:
- *Convention on International Civil Aviation, 1944* ('Chicago' Convention);
 - *International Convention for the Safety of Life at Sea, 1974* (SOLAS) (the Safety Convention); and
 - *International Convention on Maritime Search and Rescue, 1979* (the SAR Convention);
- 2.1.3 The promotion of continued cooperation in the provision of search and rescue between the Australian SAR Authority and each of the State and Territory SAR Authorities is essential; and

- 2.1.4 The National Search and Rescue Response Arrangements for coordination of resources to be used in search and rescue operations are fundamental to the success of a national search and rescue service.

3 TERMS OF THE AGREEMENT

- 3.1 The Parties agree that the National SAR Council will be the national coordinating body for search and rescue response arrangements in Australia, with the following functions:
- I. oversee the implementation of search and rescue arrangements within Australia's search and rescue region for consistency with the National Search and Rescue Response Arrangements;
 - II. sponsor and promote the development and use of the National SAR Manual, which details agreed search and rescue response and coordination arrangements in Australia; and
 - III. promote the ongoing effectiveness of the cooperative arrangements between the SAR Authorities.
- 3.2 The Parties will take such action as is provided for by this agreement and as is otherwise required to achieve the objectives of the National Search and Rescue Response Arrangements in accordance with the roles and responsibilities set out below.
- 3.3 The Parties accept the administrative and funding arrangements underpinning the operation of the National Search and Rescue Response Arrangement as outlined in this agreement.
- 3.4 The Parties will plan and resource for search and rescue responsibilities as set out in the National SAR Manual, recognising and accepting that the first SAR Authority to become aware of a search and rescue incident is obliged to respond until overall coordination can be transferred to the SAR Authority best placed to coordinate the response, in accordance with the principles set out in the National SAR Manual.
- 3.5 The Parties agree to support the National Search and Rescue Arrangement to ensure that:
- I. Australia's obligations under international conventions and agreements relating to search and rescue are fulfilled;
 - II. The national approach to search and rescue coordination is continued and strengthened;
 - III. Mechanisms are in place to facilitate cooperative decision making; and
 - IV. The obligations of Parties under this arrangement are met.

4 RESPONSIBILITIES FOR SEARCH AND RESCUE

- 4.1 The Parties agree to continue to recognise and maintain the long standing and well understood division of responsibility between the Commonwealth and the States and Territories for search and rescue in relation to persons, vessels, vehicles and aircraft.

4.2 The Australian SAR Authority

- 4.2.1 The Australian SAR Authority will have primary responsibility for coordinating search and rescue operations for:
- I. International civil aircraft, manned space vehicles and aircraft on the Civil Aviation Safety Authority (CASA) and Recreational Aviation Australia (RA-Aus) registers; and
 - II. Persons on or from a vessel at sea.
- 4.2.2 The Australian SAR Authority has a function as an Alerting Post responsible for receiving international distress alerts for onward distribution to the responsible SAR Authority as per appendix B of the NATSAR Manual.
- 4.2.3 The Australian SAR Authority will be responsible for any liaison with international search and rescue authorities that may be required in response to any search and rescue operation.
- 4.2.4 The Australian SAR Authority will be responsible for the overall coordination of any national emergency plan or arrangement involving search and rescue within the Australian search and rescue region.

4.3 State and Territory SAR Authorities

- 4.3.1 The State and Territory SAR Authorities will have responsibility for coordinating search and rescue operations for:
- I. Persons and vehicles on land;
 - II. Persons and vessels on inland waterways and in waters within the limits of the ports of the relevant State or Territory;
 - III. Persons on or from a vessel at sea;
 - IV. Aircraft not included in the CASA and RA-Aus registers including ultralights, para-gliders, hang-gliders, and gyrocopters; and
 - V. Land searches for missing registered civil aircraft in support of the Australian SAR Authority.
- 4.3.2 The State and Territory SAR Authorities will coordinate volunteer rescue organisations within their respective jurisdictions.

5 COOPERATIVE ARRANGEMENTS

- 5.1 The Parties agree to the following cooperative arrangements to underpin Australia's search and rescue system:
- I. The National SAR Manual is formally recognised as the standard reference for operational use by the Australian and the State and Territory SAR Authorities.
 - II. The Australian and State and Territory SAR Authorities are to follow the cooperative arrangements described in the National SAR Manual.

- III. The SAR Authority first becoming aware of a search and rescue incident will take all necessary action until responsibility can be handed over to the search and rescue authority better placed to take overall coordination.
- IV. When a number of SAR Authorities contribute to a search and rescue operation, one SAR Authority will have overall coordination responsibility and the others will act in support in accordance with the procedures established by the National SAR Manual.
- V. If an aviation or maritime search and rescue operation for which a State or Territory SAR Authority has overall coordination over-reaches that Authority's capabilities overall coordination may, by mutual consent, be transferred to the Australian SAR Authority in accordance with the procedures established by the National SAR Manual. Similarly, if the Australian SAR Authority is over committed with other search and rescue operations it may, by mutual consent, transfer overall coordination to a State or Territory SAR Authority. No SAR Authority will unreasonably refuse the transfer of overall coordination.
- VI. The Parties agree to ensure that any emergency management plan or arrangement that impacts on search and rescue preparedness and/or response, is considered by the National SAR Council to ensure that the appropriate coordination and harmonisation is in place.
- VII. The Parties will facilitate the involvement of State/Territory Emergency Service Agencies and other organisations within their respective areas of responsibility, to provide support to the national SAR arrangements.

6 SAR RESOURCING AND OPERATIONAL EXPENSES

- 6.1 Each Party shall provide resources to its SAR Authority based on planning for search and rescue responses as outlined above.
- 6.2 The Australian and the State and Territory SAR Authorities shall each provide, without charge unless otherwise agreed, such assistance or facilities as may reasonably be requested by the SAR Authority with overall coordination of a search and rescue operation.
- 6.3 The Australian and the State and Territory SAR Authorities will each coordinate the provision of assistance or facilities by the State/Territory Emergency Service Agencies and other organisations that support the national SAR arrangements within their respective jurisdictions, without charge unless otherwise agreed, as may reasonably be requested by the SAR Authority with overall coordination of a search and rescue operation.
- 6.4 A SAR Authority that hires or requisitions privately owned facilities for a search and rescue operation will, unless otherwise agreed between the SAR Authorities, bear any costs of hiring or payment of compensation for such requisitioning.
- 6.5 Where the resources required to respond to a search and rescue exceed those available to any Party, or where the circumstances require significant coordination across Party

6

agencies, a search and rescue may develop into an emergency management response. Where a search and rescue results in State, Territory or national emergency plans or arrangements being activated, they are to be activated in support of national search and rescue response arrangements established through this agreement.

7 OPERATION OF THE NATIONAL SAR COUNCIL

7.1 Management

7.1.1 The National SAR Council is to be chaired by AMSA and the secretariat for the National SAR Council is also provided by AMSA to facilitate the implementation of this agreement.

7.1.2 Each Party will encourage the representatives from its SAR Authority to consider a whole-of-government perspective, and not just the views of its own agency.

7.2 Membership

7.2.1 Membership of the National SAR Council comprises one representative from each of:

- I. the Australian SAR Authority,
- II. each of the State and Territories SAR Authorities, and
- III. the Australian Defence Force.

7.3 Meetings

7.3.1 The Council should meet at least annually and may conduct its business out of session, providing a record is agreed between members affirming the decisions made out of session. Meetings may be held face to face or by teleconference or videoconference. Notice of meetings and agendas will be given at least one week in advance, unless otherwise agreed by the members. Meetings will not proceed unless a majority of members are able to attend.

7.4 Costs

7.4.1 Each member of the National SAR Council bears its own costs and expenses incurred in the course of Council business.

8 AMENDMENTS

8.1 The Parties may at any time review this agreement and, if they unanimously decide to modify this agreement will take all practical steps to give effect to their decision by executing a replacement agreement.

9 COMMENCEMENT AND DURATION

9.1 This agreement will commence on the date it is signed by all Parties.

9.2 The Parties may unanimously decide to terminate this agreement, and having done so each Party will do all that is practicable to terminate it.

10 COUNTERPARTS

10.1 This agreement may be executed in any number of counterparts and by the parties on separate counterparts and all counterparts taken together constitute one document.

**ENDORSED in November 2017:
By the following representatives.**

<p>For the COMMONWEALTH:</p>  <p>.....</p> <p>The Hon Darren Chester MP Minister for Infrastructure and Transport</p>  <p>.....</p> <p>Hon Michael Keenan MP Minister for Justice</p>
<p>For the AUSTRALIAN CAPITAL TERRITORY</p>  <p>.....</p> <p>The Hon Mick Gentleman MLA <i>30/11/17</i> Minister for Police and Emergency Services</p>

Inter-governmental Agreement on National Search and Rescue Response Arrangements

For the State of NEW SOUTH WALES



.....
The Hon Troy Grant MP
Minister for Police and Emergency Services

For the NORTHERN TERRITORY



.....
The Hon Michael Gunner MLA
Minister for Police, Fire and Emergency Services

For the State of SOUTH AUSTRALIA



.....
The Hon Chris Picton MP
Minister for Police, Correctional Services, Emergency Services and Road Safety


For the State of VICTORIA



.....
The Hon Lisa Neville MP
Minister for Police

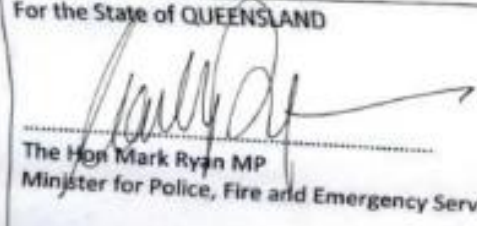
Inter-governmental Agreement on National Search and Rescue Response Arrangements

For the State of TASMANIA



.....
The Hon Rene Hidding MP
Minister for Police and Emergency Management

For the State of QUEENSLAND



.....
The Hon Mark Ryan MP
Minister for Police, Fire and Emergency Services

For the State of WESTERN AUSTRALIA



.....
The Hon Michelle Hopkins Roberts MLA
Minister for Police and Road Safety

2 JAN 2018

Appendix B – National SAR Responsibilities

DIVISION OF RESPONSIBILITY		FUNCTION TO BE PERFORMED BY, OR ON BEHALF OF, THE OVERALL COORDINATING AUTHORITY					
For land, sea and air SAR, in respect of:	Responsible Authority ¹	Provision and coordination of air SAR Assets.	Provision and coordination of land SAR Assets.	Provision and coordination of maritime SAR Assets.	Communication (other than air/surface)	Air/ground communication for land search and rescue.	Aircraft/ship communication were direct communications not available.
International civil aircraft, manned space vehicles and aircraft on the Civil Aviation Safety Authority (CASA) and Recreational Aviation Australia (RA-Aus) Registers	JRCC Australia	JRCC Australia	Police	JRCC Australia Police	JRCC Australia Police	Airservices Australia Police	Airservices Australia
Persons on or from a Vessel at Sea ²	JRCC Australia Police ³	JRCC Australia Police	Police	JRCC Australia Police	JRCC Australia Police	Airservices Australia Police	Airservices Australia Police

¹ The first SAR Authority to become aware of a SAR incident is obliged to respond until overall coordination can be transferred to the 'Best Placed' SAR Authority in accordance with the provisions of the Inter-Governmental Agreement on National Search and Rescue Arrangements 2017 and the principles set out in the National SAR Manual

² Other than those for which the ADF is responsible

³ JRCC Australia involvement when requested to arrange for the provision of aircraft or accept coordination of air search in accordance with the principles set out in the National SAR Manual

DIVISION OF RESPONSIBILITY		FUNCTION TO BE PERFORMED BY, OR ON BEHALF OF, THE OVERALL COORDINATING AUTHORITY					
For land, sea and air SAR, in respect of:	Responsible Authority ¹	Provision and coordination of air SAR Assets.	Provision and coordination of land SAR Assets.	Provision and coordination of maritime SAR Assets.	Communication (other than air/surface)	Air/ground communication for land search and rescue.	Aircraft/ship communication were direct communications not available.
Persons and vehicles on land ⁴ ; and Persons and vessels on inland waterways and in waters within the limits of the ports of the relevant State or Territory	Police	Police JRCC Australia	Police	Police	Police	Police Airservices Australia	Police Airservices Australia
Aircraft not included in the CASA and RA-Aus registers including ultralights, paragliders, hang-gliders, and gyrocopters (unregistered aircraft).	Police	Police JRCC Australia	Police	Police JRCC Australia	Police Airservices Australia	Police Airservices Australia	Police Airservices Australia
Australian Defence Force (ADF) and Foreign Military Personnel, Aircraft, Ships and Submarines	ADF ⁵	ADF	ADF	ADF	ADF	ADF	ADF

⁴ JRCC Australia involvement when requested to arrange for the provision of aircraft or accept coordination of air search in accordance with the principles set out in the National SAR Manual

⁵ ADF involvement in search and rescue is arranged through HQJOC (Headquarters Joint Operations Command) in accordance with the principles set out in the National SAR Manual

Appendices

DIVISION OF RESPONSIBILITY		FUNCTION TO BE PERFORMED BY, OR ON BEHALF OF, THE OVERALL COORDINATING AUTHORITY					
For land, sea and air SAR, in respect of:	Responsible Authority ¹	Provision and coordination of air SAR Assets.	Provision and coordination of land SAR Assets.	Provision and coordination of maritime SAR Assets.	Communication (other than air/surface)	Air/ground communication for land search and rescue.	Aircraft/ship communication were direct communications not available.
Unidentified Distress Beacon Alerts	JRCC Australia	JRCC Australia	Police	JRCC Australia Police	JRCC Australia	JRCC Australia Airservices Australia	JRCC Australia Airservices Australia
In respect to persons on oil and gas facilities at sea associated with the exploration, production, storage and offloading of product.	JRCC Australia Police* ⁶	JRCC Australia Police	Police	JRCC Australia Police	JRCC Australia Police	Airservices Australia Police	Airservices Australia Police

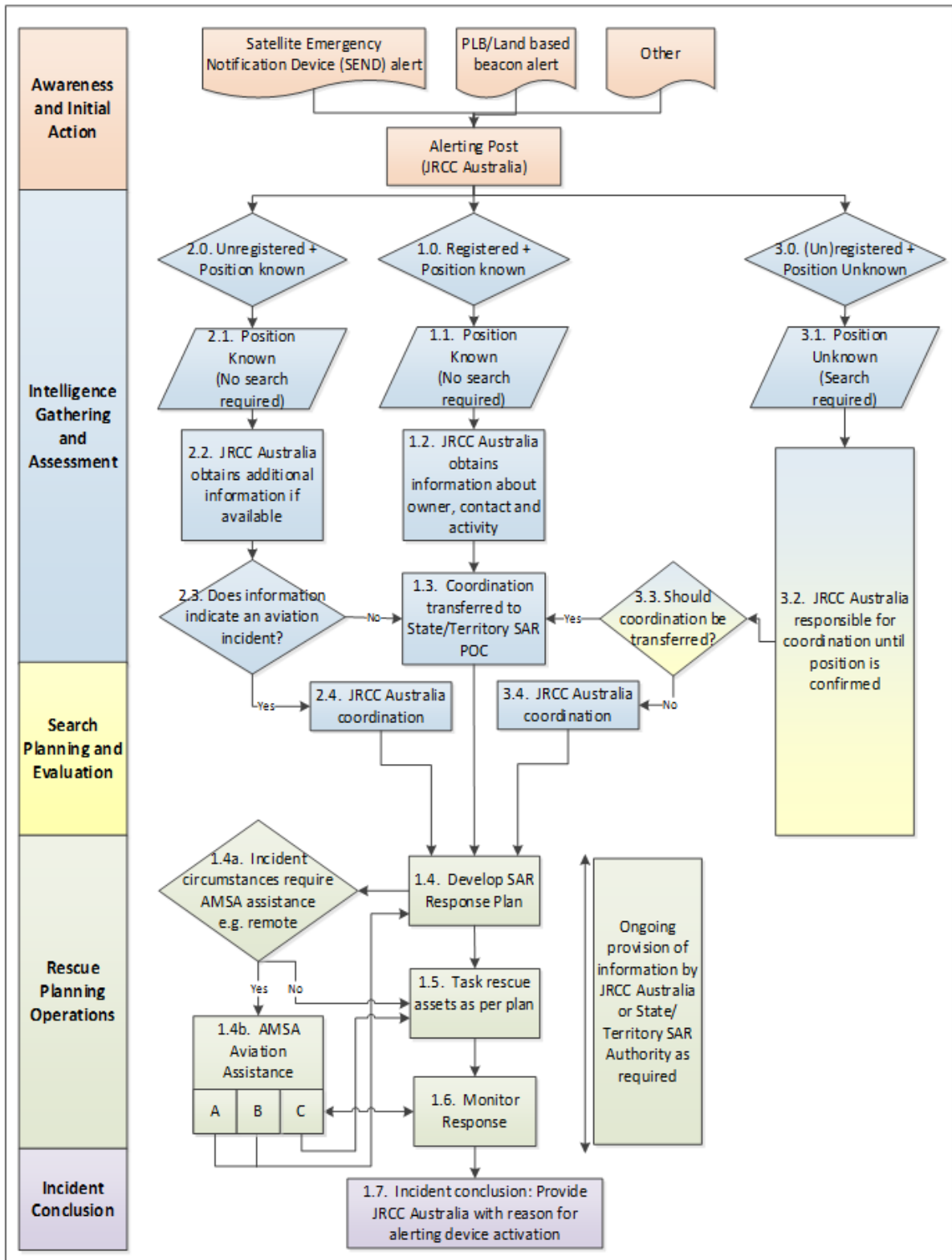
NB: This responsibility matrix relates only to search and rescue responsibilities and does not replace the responsibilities of other organisations as they relate to safety, security and environmental issues on Oil and Gas facilities.

*Responsibility for the rescue of persons from oil and gas facilities at sea will be determined in accordance with the 'Best Placed' provisions.

Will require that National Offshore Petroleum Safety and Environmental Management Authority (NOPSEMA) is informed of this change.

Appendix C – National Operational Procedure for Transfer of Coordination

Overview



Appendices

Guidelines for Procedure to transfer coordination

1.0	The term 'position known' means that the position accuracy is nominally within 5 kilometres, and for GPS encoded positions are normally within 150 meters. An appropriately trained response team should be able to localise the final beacon position on scene in line with respective procedures.
1.3	<p>Transfer of coordination and information between JRCC Australia and State/Territory will occur with the agreed SAR point of contact in each jurisdiction, which already exists (attachment 1).</p> <p>Provision of transfer of coordination and incident information will occur both in writing and verbally:</p> <p>Written exchange – Written information will include, position information, beacon registration information if known, and any other relevant intelligence obtained.</p> <p>Verbal exchange – The recognised time of transfer of coordination will be when verbal agreement occurs.</p> <p>Example of this information is provided in Appendix D of the NATSAR Manual. The information exchange will occur almost simultaneously, normally with the written information provided first, followed by a telephone call. Other means of transferring information to the coordinating authority will be considered upon request.</p>
1.4	A response will be planned by the respective jurisdiction in line with their procedures.
1.4a	When developing the SAR Response Plan, the coordinating SAR authority may determine that aviation assistance is required from JRCC Australia due to circumstances specific to that incident e.g. the location is in a particularly remote area.
1.4b	<p>JRCC Australia can provide three types of aviation assistance:</p> <ol style="list-style-type: none"> Identification of suitable aviation SAR assets Identification and briefing provided for suitable aviation SAR assets Identification, briefing and tasking of suitable aviation SAR assets. <p>If assistance a) or b) is requested, then JRCC Australia will provide the relevant information to the coordinating authority to assist in further developing the SAR Response Plan.</p> <p>If assistance c) is requested, then JRCC Australia will task the asset but will still remain in a supporting role to the coordinating SAR Authority. The intention is for the coordination SAR Authority to have direct communications with the aircraft responding to the incident where possible. This is the best practice to ensure the SMC and the ground parties responding have real time and accurate information without delay. It is understood that there may be some communications limitations especially outside of state contracted assets, but the intention is to transition to this operational practice. If this capability does not exist, JRCC Australia will provide a relay of relevant information as required.</p>
1.6	The SMC of the coordinating SAR authority has responsibility to monitor the progress of the SAR Response Plan and will be provided with updates of ongoing information if obtained by JRCC Australia.
1.7	As international SPOC, JRCC Australia is required to provide incident reports to COSPAS-SARSAT as per our international agreement, including reason for activation and number of lives saved etc. Upon incident conclusion, the coordinating SAR authority will forward this information to JRCC Australia.
2.2	If registration details are not available JRCC Australia will continue with inquiries to obtain additional information. Unless it is determined that it is an aviation incident, coordination will be transferred to the appropriate State/Territory SAR Authority.
3.2	When the position is unknown, JRCC Australia will retain coordination and take appropriate action to confirm the position. In accordance with the NATSAR Manual Volume 1, Chapter 1.2.10, JRCC Australia and the respective State/Territory SAR authority will have a discussion regarding the best placed SAR authority to take coordination, based on the incident circumstances.

State / Territory SAR Authority Points of Contact

State	Contact
NSW	Sydney Police COM Centre Rescue Coordinator (RCO)
QLD	Police SARMC for the district, backup Brisbane Police COM Centre Duty Sergeant
NT	Police COM Centre Darwin
WA	Police COM Centre Perth Duty Inspector, then as agreed for local Police contacts
SA	Police STAR Group Shift Manager, if no contact Police COM Centre
VIC	Police RCC
TAS	Police Radio Dispatch Services (RDS) Centre, Tasmania Police COM Centre Hobart
ACT	ACT Policing Operations Centre
Australian External Territories	Australian Federal Police Nation Operations State Service Centre (NOSSC)

Transfer of Coordination Information Exchange Requirements

In accordance with Section 1.2.30 and 1.2.35 of the manual, transfer of coordination is deemed to have taken place at the time verbal agreement is reached. The transfer of coordination is to be recorded appropriately within each Authority's incident management system.

The transfer of coordination can involve overall coordination or specific sub-components of the search activity e.g. Land\Air\Sea search coordination. Transfer discussions will only be undertaken between appropriately authorised person(s) of respective SAR Authority's.

Noting that each SAR Authority has fit for purpose record keeping systems the following is to be used as a guide for information that shall be transferred electronically to another SAR agency as part of the transfer of coordination process.

Item	Comment
Timestamp	System generated Date\Time stamp
Reference telephone call for time of verbal transfer	Reference telephone call between SAR Authorities in which verbal transfer of coordination was agreed
Incident Identifier and short description	Authority Incident\CAD reference number, short title of incident and plain language description
Coordination Transfer	Details of coordination element to be transferred, possibilities include ⁶ : <ul style="list-style-type: none"> - Overall Coordination - Land Search - Sea Search - Air Search
Current Situation	Assessment of the current situation by the coordinating SAR authority
Intelligence and Actions undertaken	A summary of known information and actions completed

⁶ Delete those that are not applicable

Appendices

Incident location	Incident location details, at a minimum Latitude and Longitude (decimal degrees) are to be provided Additional positional formats can be provided, e.g. Grid Reference, embedded GPS position
Additional incident support requirements	Additional incident support requirements as agreed between SAR authorities, examples could include forward command post support, next of kin liaison, radio broadcasts etc.
Supplementary Information	Information pertaining to the target e.g. beacon registration details, target operator details and contacts, trip details

Example: Transfer of Coordination information

192359 UTC Jun 2015

FM JRCC AUSTRALIA

TO [State\Territory SPOC]

INFO [As required]

INCIDENT 2015/1234 - TRANSFER OF SEARCH AND RESCUE [OVERALL COORDINATION\AIR SEARCH\LAND SEARCH\SEA SEARCH] – PLB\SEND DEVICE LOCATED XXX

Ref A. Telecon JRCC Australia \ [State\Territory SPOC] 192350 UTC JUN 2015

Ref B. NATSARMAN xx.x

1. COORDINATION TRANSFER

IN ACCORDANCE WITH REF A, JRCC AUSTRALIA HEREBY FORMALLY REQUEST THE TRANSFER OF [OVERALL\AIR SEARCH\LAND SEARCH\SEA SEARCH, IN ACCORDANCE WITH PARAGRAPH 1.2.31 OF THE NATIONAL SEARCH AND RESCUE MANUAL, FOR THE SEARCH AND RESCUE ACTION FOR RESPONSE TO THE ACTIVATION OF A [DEVICE] ACTIVATED AT [DDHHMM UTC MMM YYYY].

2. CURRENT SITUATION:

JRCC AUSTRALIA RECEIVED PLB DETECTION AT 19 2230UTC. THE JRCC HAS CONFIRMED THERE IS A PARTY OF FOUR PERSONS CANYONING IN X AREA AND THAT THEY REPORTED THEY WOULD ONLY ACTIVATE THE BEACON IN CASE OF A SERIOUS INJURY OR ACCIDENT. THE PARTY DEPARTED THIS MORNING, NO OTHER INFORMATION REGARDS SAFETY EQUIPMENT IS KNOWN. AIRCRAFT TRANSITING THE AREA HAVE BEEN REQUESTED TO REPORT ANY HEARING REPORTS IN THE AREA.

3. INTELLIGENCE AND ACTIONS UNDERTAKEN:

JRCC AUSTRALIA HAS CONTACTED THE REGISTERED BEACON OWNER EMERGENCY CONTACTS. THEY ADVISE THAT THE BEACON HAS BEEN LOANED TO X AND Y, THEY ARE CURRENTLY CANYONING IN THE X AREA WITH FOUR OTHER PERSONS. THE FOLLOWING CONTACT\COMMUNICATION DEVICES ARE IN POSSESSION OF THE REGISTERED OWNERS.

4. INCIDENT LOCATION:

- A. LATITUDE\LONGITUDE: 39-14.5S 142-54.76E
- B. *GRID REFERENCE: 54H 665062 5654661 UTM
- C. *EMBEDDED GPS POSITION: 39-14.5S 142-54.7E

* AS APPLICABLE

5. ADDITIONAL INCIDENT SUPPORT REQUIREMENTS

IN ACCORDANCE WITH REQUEST OF [STATE\TERRITORY SPOC] JRCC AUSTRALIA HAS TASKED [RESCUE 431 CHALLENGER 604 TIER 1 AIRCRAFT] ETA ON SCENE IS ADVISED AS 200112 UTCJUN 2015.

6. SUPPLEMENTARY INFORMATION, BEACON REGISTRATION INFORMATION

Registered Beacon Details

Status

Operational

Organisation

ATTN: MANAGER OPERATIONS

Owner (Last Updated: 12/08/2015)

AMSA ER
GPO Box 2181
CANBERRA, ACT 2601

Phone: (W) 02 6230 6811

Fax: 02 6230 6868

Email: rccaus@amsa.gov.au

Remarks:

Internal Comments:

Emergency Contacts

<i>Contact Name</i>	<i>Home Phone</i>	<i>Work Phone</i>	<i>Mobile Phone</i>
SSARO on duty		1800 641 792	

Beacon Details (Last Updated: 12/08/2015)

Hex: 3EF699F53F81FE0

Manufacturer GME - Standard Communications Pty Ltd

Manufacturer Serial # 912175012

Model MT410G PLB

Comments * 1AUG15 - 4WD trip with family to Mount Kosciuszko. 2 x Adults and 2 x Children. Returning sunday night 2AUG15.

Internal Comments

Primary Use: Vehicle Details (Last Updated: 12/08/2015)

Make/Model Toyota Rav4

Year 2008

Rego JU45KL

Colour Black

Call Sign

UHF No

HF No

Satellite Phones

REGARDS,

JRCC AUSTRALIA

Appendix D

Overview

- Appendix D-1 Distress Emergency Signals
- Appendix D-2 Maritime SAR Recognition Codes
- Appendix D-3 Plotting Symbols
- Appendix D-4 Sighting and Hearing Techniques
- Appendix D-5 Tables and Graphs
- Appendix D-6 Probable Positions of Error
- Appendix D-7 Worksheets
- Appendix D-8 Aircraft Accident Site Precautions
- Appendix D-9 Civil Aircraft Search and Rescue Assets (SRAs)
- Appendix D-10 Coastal Datum Search and Rescue Planning

Appendix D-1 Distress Emergency Signals

Overview

Many signals have been devised over the years to signal a condition of distress or other emergency status. Those listed in this Appendix are those which are most common, have been accepted by international agreement or national custom, or which may be significant for occasional use by SAR assets.

Because of the large number of possible signals of various types that may be used to indicate an emergency condition or may be used for emergency communication, this list is not all-inclusive.

International Distress Signals

- a) A gun or other explosive signal fired at intervals of about one minute;
- b) A continuous sounding of any fog-signalling apparatus;
- c) Rockets or shells, throwing red stars fired one at a time at short intervals.
- d) A signal made by any signalling method consisting of the group ...---... (SOS) in the Morse Code;
- e) A signal sent by radiotelephony consisting of the spoken word 'Mayday'
- f) The International Code Signal of distress indicated by the code group NC; (See the International Code of Signals for other code groups with emergency significance.)
- g) A signal consisting of a square flag having above or below it a ball or anything resembling a ball;
- h) Flames on a vessel (as from a burning tar barrel, etc.);
- i) A rocket parachute flare or a hand flare showing a red light;
- j) A smoke signal giving off a volume of orange-coloured smoke;
- k) An orange-coloured sheet with a black square and circle or a black "V" or other appropriate symbol;
- l) Slowly and repeatedly raising and lowering arms outstretched to each side;
- m) The radiotelephone alarm signal consisting of two tones transmitted alternatively over periods of from 30 seconds to 1 minute;
- n) Signals transmitted by Emergency Position Indicating Radio Beacons, EPIRB's or Personal Locator Beacons (PLBs) , Emergency Locator Transmitters (ELT's) ;
- o) Approved signals transmitted by radio communication systems;
- p) A dye marker; and
- q) Transponder Squawk Codes 7700 Emergency, 7600 Communications failure, 7500 Unlawful interference.

Search and Rescue Signals – Australian Area

Signals with Surface Craft

When it is necessary for an aircraft to direct a surface craft to the place where an aircraft or surface craft is in distress, the aircraft shall do so by transmitting precise instructions by any means at its disposal. If such precise instructions cannot be transmitted or when necessary for any other reason, the instructions shall be given by using the procedure prescribed herein.

The following procedures performed in sequence by an aircraft shall mean that the aircraft is directing a surface craft towards an aircraft or a surface craft in distress:

- a) Circling the surface craft at least once;
- b) Crossing the projected course of the surface craft, close ahead at a low altitude, opening and closing the throttle or changing the propeller pitch; and
- c) Heading in the direction in which the surface craft is to be directed.

The following procedure performed by an aircraft shall mean that the assistance of the surface craft to which the signal is directed is no longer required:

Appendices

- a) Crossing the wake of the surface craft close astern at a low altitude, opening and closing the throttle or changing the propeller pitch.
- b) Repetition of such procedures shall have the same meaning. Current maritime signalling procedures include:
 - i) For acknowledging receipt of signals:
 - ii) The hoisting of the Code Pennant (vertical red and white stripes) close up (meaning understood);
 - iii) The flashing of a succession of T's by signal lamp in Morse code; and
 - iv) The changing of heading.
- c) For indicating inability to comply:
 - i) The hoisting of the international flag N (a blue and white checked square); and
 - ii) The flashing of a succession of Ns in Morse code.

Civil Air-Ground Code

Australian Civil Authorities use the following air-ground codes:

Signal	Meaning
Aircraft orbits ground party at low level changing engine noise	I require your attention
Aircraft flies overhead of ground party at low level and sets off in a particular direction.	Follow aircraft in same direction
Aircraft rocks wings and orbits.	Investigate object/position underneath aircraft orbit
Aircraft drops smoke on a particular location	Investigate object/position adjacent to smoke
Aircraft drops message canister.	Retrieve and read instructions contained in the canister

Table D-1:1 Ground Air Visual Signal Code

International SAR Signals

The following visual signals are internationally recognised. They are authorised for use in the Australian SRR.


Number	Message	Code Symbol
1	Require Assistance	V
2	Require Medical Assistance	X
3	Proceeding in this Direction	
4	Yes, or Affirmative	Y
5	No, or Negative	N

Table D-1:2 Ground-Air Visual Signal Code for Use by Survivors

Note: If in doubt use International Signal – SOS

Number	Message	Code Symbol
1	Require Fodder	FF
2	Require Evacuation	III
3	Power Failure	VI

Table D-1:3 Ground-Air Visual Signal Code for Use in Civil Emergencies

Notes:

1. Aldis Lamp Signals
 - a) Red flashes indicate not understood
 - b) Green flashes indicate message understood
2. Air-Ground Signals

The following signals by aircraft mean that the signals have been understood:

 - a) During hours of daylight – rocking the aircraft’s wings
 - b) During hours of darkness – by flashing the aircraft’s landing or navigation lights ON and OFF twice. Lack of the above signals indicates that the message has not been understood.
3. Tables D-1:1, D-1:2 and D-1:3 conform to ICAO and NATO standards

Appendix D-2 Maritime SAR Recognition Code (MAREC)

Overview

The purpose of this Code is to facilitate the communication of essential descriptive information regarding merchant ships and small craft within and between SAR maritime organisations.

The MAREC Code is in two parts:

- Part 1 – Merchant Vessels; and
- Part 2 – Small Craft.

All messages should be preceded with the prefix MAREC followed by a local serial number, assigned by the RCC.

The message should contain all the lettered identification groups as separate paragraphs. If the information is not known, the symbol UNK should be inserted or alternatively the symbol NA, where the lettered group is not applicable.

Fishing vessels have not been included due to the multiplicity of types and configurations. Use should be made of the Merchant Vessels description code to report the description of fishing vessels.

Part 1 – Merchant Vessels

Merchant Vessels MAREC Messages

The Message is composed of the following identification groups and will be transmitted in the following sequence:

Group	Description
A	Type of vessel - name - call sign
B	Superstructure - location - colour
C	Hull profile - colour
D	Sequence of uprights
E	Length
F	Condition of loading
G	Other characteristics.

Table D-2:1 MAREC – Local Serial Number

A. Type of Vessel – Name – Callsign

Merchant ships are classified as follows:

VOICE	TLX/RTG
Passenger ships	PAX
Ferry	FERRY
Tankers	TANK
Bulk carriers	BULK
General cargo ships	GEN
Coaster	COAST
Fishing vessels	FISH
Container ships	CONT
Specialised ships	SPEC

Table D-2:2 Mership Classifications

The name and callsign is added to the above classification.

For specialised vessels, the specific type of vessel should be given, as appropriate, e.g. gas carrier, tug, icebreaker, etc.

Example:

Voice: ALFA, SPECIALISED SHIP GAS CARRIER, FLYING DRAGON, CHARLIE GOLF HOTEL INDIA.

TLX/RTG: A/SPEC/GAS CARRIER/FLYING DRAGON/CGHI

B. Superstructure – Location and Colour

Superstructures are referred to as being located forward, midship or aft or a combination of these positions, and may be described as long or short. Colour is given in plain language.

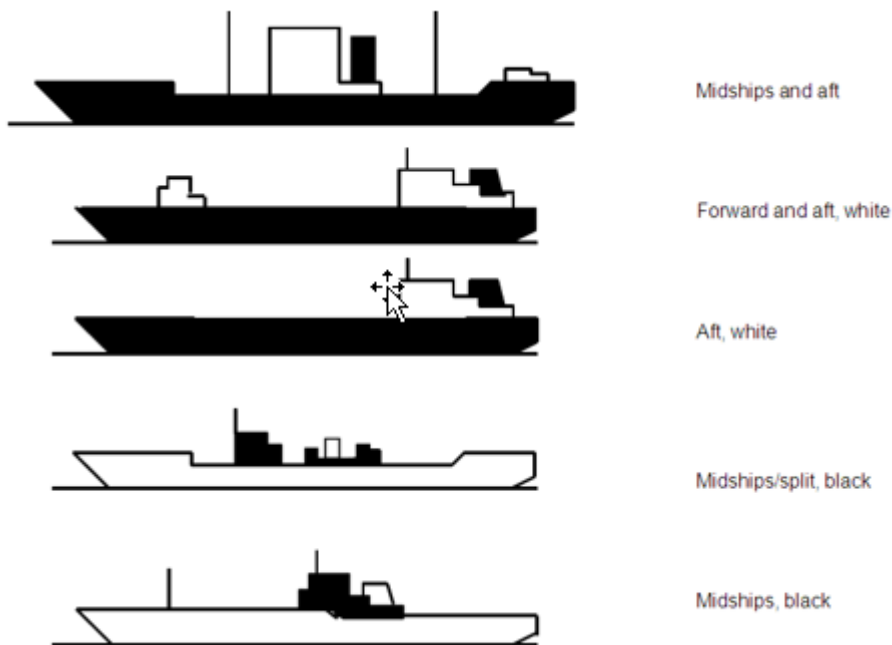


Figure D-2: 1 Superstructure Locations/Colour

Note: A superstructure that has a very distinct gap, as in the fourth illustration above should be reported as “location” split.

Example (as in the first illustration above)

Voice: BRAVO, SUPERSTRUCTURE MIDSHIP AND AFT, WHITE

TLX/RTG: B/MIDSHIPS AND AFT/WHITE

C. Hull – Profile and Colour

The hull profile is divided into three sections numbered 1, 2 and 3 from stem to stern as follows:

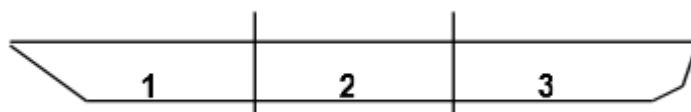


Figure D-2: 2 Hull Division

If any section of the main weather deck of a vessel (except for superstructure) is raised, this is reported by its respective number as shown below. Should there be a break between deck raises, an oblique line (voice - 'SLANT') will be inserted in between the relevant section numbers. Should there be no break as referred to above, the numbers will be written consecutively.

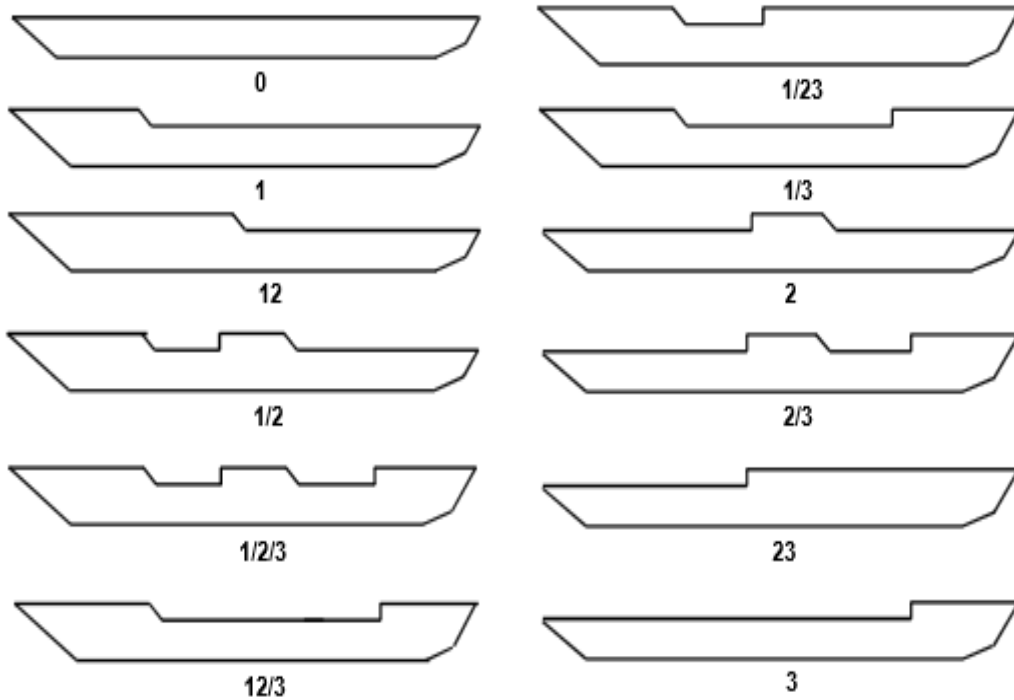


Figure D-2:3 Full Profiles

Note of Caution:

Do not confuse raises in the decline with bulwarks which extend the height of the hull profile about 1 m and are used to protect deck cargo and personnel from washing over the side. They look like fences around exposed weather decks and can be usually recognised by the presence of small holes for deck drainage (scuppers) and the lack of handrails (see Figure D-2:12 below).

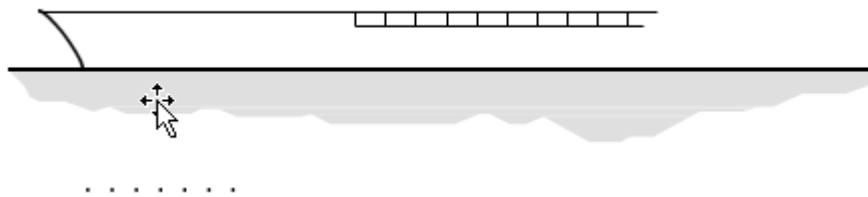


Figure D-2:4 Bulwark

The colour of the hull is given in plain language.

Example:

Voice: CHARLIE, PROFILE ONE TWO SLANT THREE, BLACK

TLX/RTG: C/12/3/BLACK.

D. Uprights

Uprights include everything, other than the profile and the superstructures that are prominent and can clearly be seen at a distance. The uprights are reported from stem to stern according to the list below:

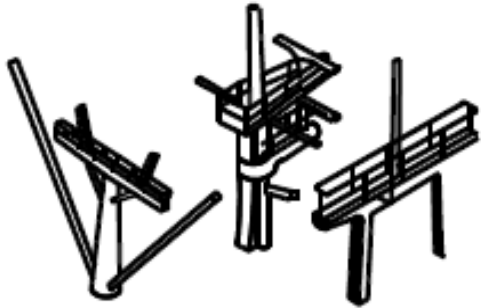
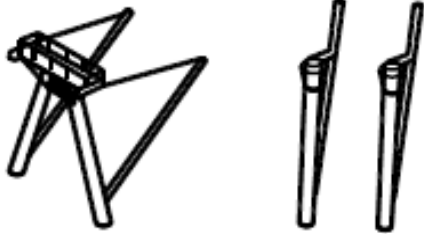


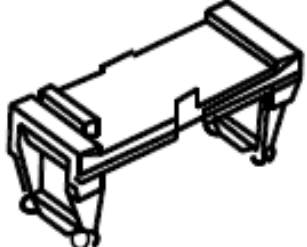
Voice	TLX/ RTG	Description	Illustration
Mast	M	Slender posts consisting of a lower section with a thinner upper section. Used to support signals, flags, navigation lights, radar antennae etc. Generally the highest of the uprights.	
Kingpost	K	Slender uprights resembling the thickness or heaviness of the lower section of masts. They are used to support cargo booms. If there is a pair of king posts athwartships (perpendicular to the vessel's centreline), the pair is reported as one kingpost. A kingpost with mast extensions is reported as a mast.	
Funnel	F	Used to exhaust the vessel's main propulsion systems. Most vessels have one although some of the older ships have more.	
Crane	C	Self-contained mechanisms with a boom extending from them.	
Gantry	G	Mobile structure limited to fore-aft movement supporting a central crane.	

Figure D-2:5 Uprights

Uprights located close to a superstructure such that they cannot be clearly seen from a distance should not be included.



Figure D-2:6 Example of Uprights

Example:

Voice: DELTA, MAST, KINGPOST, MAST, KINGPOST, FUNNEL

TLX/RTG: D/M K M F

E. Length

Length is the length overall (LOA) given in metres.

Note: Length can be estimated by observing the vessel's lifeboats, normally 10 metres long, in proportion to the ship's length.

Example:

Voice: ECHO, TWO ZERO METRES

TLX/RTG: E/LOA 20

F. Conditions of Loading

The condition of loading is indicated as follows:

Voice	TLX/RTG	Description	Illustration
Light	Light	Carrying only fuel and stores. Sitting high in water. Propeller and rudder partly exposed. Difficult to manoeuvre.	
In ballast	Ball	Carrying ballast. Sitting high in water. Propeller and rudder normally submerged. Large amount of lower hull paint showing.	
Partially loaded	Part	Sitting well in water. Fair amount of lower hull paint showing.	
Fully loaded	Load	Sitting deep in the water. Little, if any, lower hull paint showing.	

Figure D-2:7 Conditions of Loading

Example

Voice: FOXTROT, PARTIALLY LOADED

TLX/RTG: F/PART

G. Other characteristics

Other prominent characteristics should be given, e.g. stack insignia, conspicuous deck cargo, or other distinguishing marks or colour variations, e.g. name in big letters on ship's side or company insignia painted on side of hull. In the message, such specific characteristics should be given in full.

Example:

Voice: GOLF, RAILROAD CARS ON DECK

TLX/RTG: G/RAILROAD CARS ON DECK

Complete example Merchant Ship

The following illustrates a typical merchant vessel and how it would be described in a message according to this system.

Voice:	TLX/RTG:
MAREC 5/03 RCC AUSTRALIA ALFA , GENERAL CARGO SHIP, ARAFURA, VICTOR ROMEO ROMEO YANKEE BRAVO , SUPERSTRUCTURE AFT, WHITE CHARLIE , PROFILE ONE, SLANT THREE, BLACK DELTA , MAST, MAST, MAST, FUNNEL, KINGPOST ECHO , TWO FOUR ZERO METRES FOXTROT , PART GOLF , NOT APPLICABLE	MAREC 5/76 RCC AUSTRALIA A /GEN/ARAFURA/VRRY B /AFT/WHITE C /1/3/BLACK D /M M M F K E /LOA 240 F /PART G /NA.



Figure D-2:8 Typical Merchant Ship

Part 2 – Small Craft

Small Craft MAREC Message

The message is composed of the following identification groups and will be transmitted in the following sequence:

A	Type of craft/ number of hulls – name – callsign or ship station identity – use
B	Make - distinctive markings
C	Motor installation or rigging
D	Construction - material – colour
E	Stern – stern
F	Type of bottom
G	Length.
H	Other characteristics
I	Number of persons on board.

Table D-2:3 MAREC - Local Serial Number

A. Type, configuration and superstructure of craft/number of hulls, name, callsign and use

Type is based on primary means of propulsion.

Propulsion	Type	Voice	TLX/RTG
Motor	Motor Boat	Motor	MOT
Sail	Sailing Boat	Sailing	SAIL
Oars	Rowing Boat	Rowing	ROW
Paddles	Canoe	Canoe	CAN
Motor and sail (in equal proportion)	Motor/Sailer	Motorsail	MOTSAIL
Various	Inflatable	Inflatable	INFLAT

Table D-2:4 Type of Small Craft

Configuration is based on decked-in watertight areas.

Voice	TLX/RTG	Description
Open	O	Free of decks that enclose a watertight area
Part Open	PO	Partly decked to create watertight areas
Closed	CL	Fully decked so that, with all hatches closed and bungs in, the entire hull volume is watertight
Superstructure	TLX/RTG	Description
Full Cabin	FC	Cabin superstructure from bow to stern
Part Cabin	PC	Any cabin superstructure not from bow to stern
Full Raised Deck	RD	Entire deck level is raised to provide accommodation in the hull. Identified by the presence of windows in the hull without any superstructure
Part Raised Deck	PD	Where only part deck level is raised as above

Table D-2:5 Configuration of Small Craft

When reporting the above both voice and TLX/RTG items should be incorporated in one group as below:

An open, part cabin motor boat should be reported as:

- **Voice:** MOTOR OPEN PART CABIN
- **TLX/RTG:** MOTOPC

A closed, part cabin sailing boat should be reported as:

- **Voice:** SAIL CLOSED PART CABIN
- **TLX/RTG:** SAILCLPC

Where the number of hulls is more than one, adding the words or group as follows should indicate this:

- 2 hulls - Catamaran – CAT
- 3 hulls -Trimaran - TRI

The craft's name, call sign and use should be added to words or groups above. Under use, indicate the purpose for which the craft is being used, e.g. fishing, pilot boat, offshore racer, etc.

Example:

Voice: ALFA, MOTOR PART OPEN PART CABIN CATAMARAN, LUCKY LADY, NAVIS ONE THREE, PLEASURE

TLX/RTG: A/MOTPOPC/CAT/LUCKY LADY/NAVIS 13/PLEASURE

B. Make and Distinctive Markings

The make and distinctive markings should be given in plain language.

Example:

Voice: BRAVO, MAKE STORTRISS, SAIL MARKINGS TWO OVERLAPPING TRIANGLES WITH POINTS UP AND NUMBER SIERRA ONE THREE EIGHT

TLX/RTG: B/STORTRISS/SAILMARKINGS TWO OVERLAPPING TRIANGLES POINTS UP/ S138

C. Motor Installation or Sail Rigging

The motor installation is given according to the figures shown below:

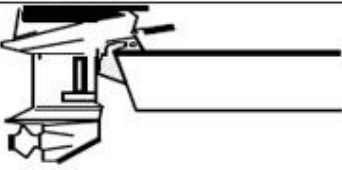
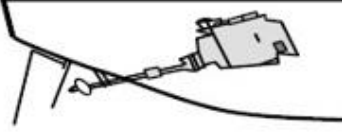

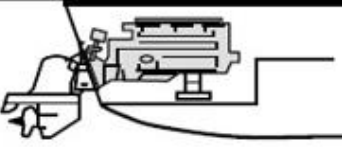
Illustration	Voice	TLX/RTG
	Outboard motor, if applicable with the addition Double or Triple.	OUTB OUTB2 OUTB3
	Inboard motor	INB
	Jet	JET
	Aquamatic if applicable with the addition Double or Inboard/Outboard	AQUA AQUA2 INBOARD/OUTBOARD

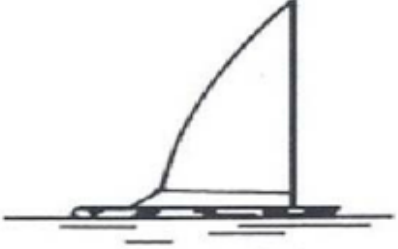

Figure D-2:9 Motor Installation


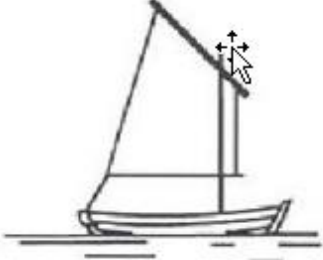


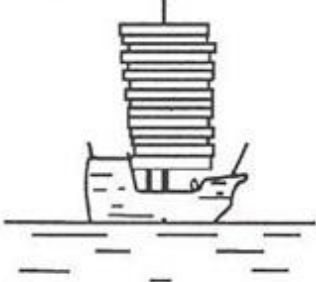
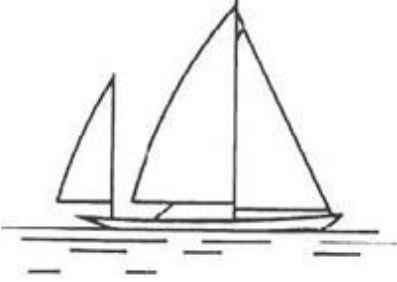
Example

Voice: CHARLIE, OUTBOARD MOTOR, DOUBLE

TLX/RTG: C/OUTB 2

Rigging (sailing boats) - Type of rigging is described on sailing boats and motor sailers according to the figures below. (The number of masts is denoted by the appropriate number):

Illustration	Voice	TLX/RTG
	Jib Rig	JIB
	Spirit Rig	SPRI

	<p>Gaff Rig</p>	<p>GAFF</p>
	<p>Lug Sail</p>	<p>LUG</p>
	<p>Lanteen Sail</p>	<p>LAT</p>
	<p>Sloop Rig</p>	<p>SLOOP</p>
	<p>Junk Rig</p>	<p>JUNK</p>
	<p>Yawl</p>	<p>YAWL</p>

Appendices

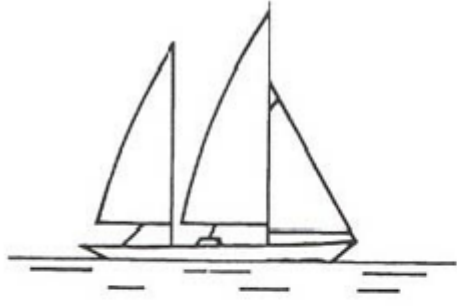
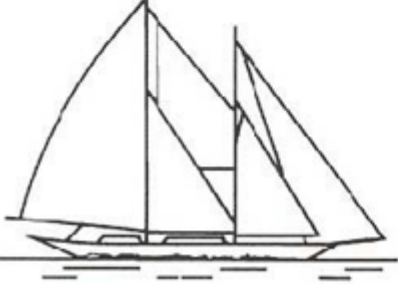
	Ketch	KETCH
	Schooner	SCHON

Figure D-2:10 Sailing Rigging

These boats have the capability to carry a bowsprit, that is a spar extending from the bow to which headsails are attached. These are reported on:

Voice: Bowsprit or

TLX/RTG: BS.

The difference between a ketch and a yawl is:

- a) The ketch’s aft mast is stepped forward of the rudder post; and
- b) The yawl’s mast is stepped behind the rudder post.

Most sailing boats carry sails known as “extras” to improve the boat’s performance in specific conditions and include spinnakers, spinnaker staysails, jib staysails, main staysails and mizzen staysails. If these sails are in use, identification of the yacht’s rig becomes more difficult. These should be reported in section H.

Name	Voice	TLX/RTG
Spinnaker	Spinnaker	SPIN
Spinnaker Staysail	Spinnaker Staysail	SPINSS
Jib Staysail	Jib Staysail	JIBSS
Main Staysail	Main Staysail	MAINSS
Mizzen Staysail	Mizzen Staysail	MIZZENS

Table D-2:6 Sail Types

D. Construction/Material/Colour

Construction

Two different types of construction exist, viz. clinker-built and carvel built or smooth sided.

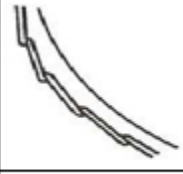
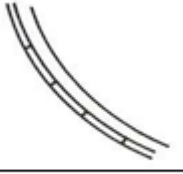
		Note: Some glass fibre boats are moulded to resemble clinker built and should be so described in this Code.
Clinker	Carvel	

Figure D-2:11 Construction

Material

The materials commonly used to construct small craft are wood, metal, glass reinforced plastic (fibreglass) (GRP), rubber (inflatables) or ferro-cement. Construction material and colour should be given in voice reports and given the abbreviations WOD, MTL, GRP, INFLAT or FERC in TLX/RTG reports.

Example:

Voice: DELTA, CLINKER, GLASS FIBRE, WHITE

TLX/RTG: D/CLINKER/GRP/WHITE.

E. Stem/Stern

Stem and stern designs are described according to the figures below:

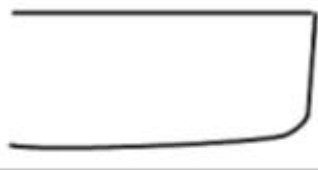

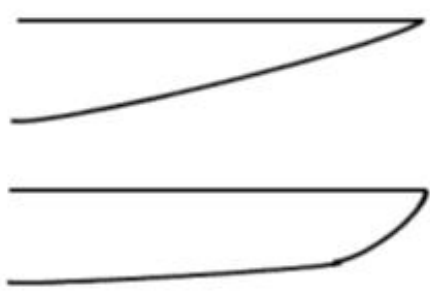
STEM	VOICE	TLX/RTG
	Straight stem	STR
	Clipper stem	CLIP
	Falling stem	FALL

Figure D-2:12 Stem Designs

Example:

Voice: ECHO, FALLING STEM, CANOE STERN

TLX/RTG: E/FALL/CAN

F. Type of Bottom

Bottom types are described according to the figures below:





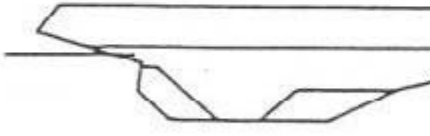
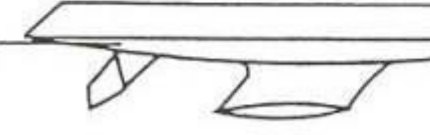
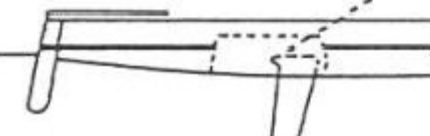
Bottom	Voice	TLX/RTG
	V-bottom	VBOT
	Flat bottom	FLAT
	Round bottom	ROUND
	Ribbed bottom	RIB
	Keel	KEEL
	Fin-keel (where double fin-keel, add the word "double")	FIN
	Centre-board	CB

Figure D-2:13 Bottom Designs

Example:

Voice: FOXTROT, RIBBED BOTTOM

TLX/RTG: F/RIB

G. Length

Length is the length overall (LOA) given in metres.

Example:

Voice: GOLF, TWO ZERO METRES

TLX/RTG: G/LOA/20.

H. Other Characteristics

Other characteristics should be included to describe certain details that might facilitate identification, e.g. flying bridge, windscreens, dodger, spinnaker sail colouring, pulpit, pushpit, steering vane etc.

Example:

Voice: HOTEL, RED SPINNAKER

TLX/RTG: H/RED SPINNAKER.

I. Number of Persons on Board (POB)

Example:

Voice: INDIA, THREE

TLX/RTG: I/3.

Complete Example: Motor Boat

1..1 Voice	1..2 TLX/RTG
MAREC 7/03, RCC AUSTRALIA ALFA , MOTORBOAT PART CABIN, GALANT, VICTOR KILO ONE EIGHT ZERO, PLEASURE BRAVO , MAKE SOLO TWO FIVE CHARLIE , INBOARD MOTOR DELTA , CLINKER, GLASS FIBRE, WHITE ECHO , FALLING STEM, SQUARE STERN FOXTROT , V-BOTTOM GOLF , SEVEN AND A HALF METRES HOTEL , PULPIT FORWARD, WINDSCREEN ONE AFT EDGE OF CABIN WITH A RED DODGER INDIA , TWO	MAREC 7/76 RCC AUSTRALIA A /MOTPC/GALANT/VK180/PLEASURE B /SOLO/25 C /INB D /CLINKER/GRP/WHITE E /FALL/SQUARE F /VBOT G /LOA 7.5 H /PULPIT FORWARD, WINDSCREEN ON AFT EDGE OF CABIN WITH RED DODGER I /2



Figure D-2:14 Motor Boat





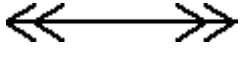

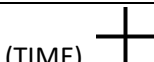
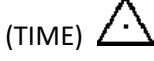
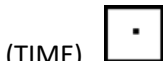



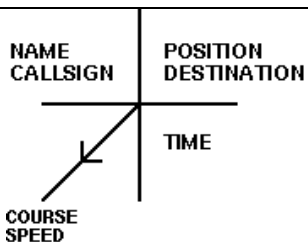
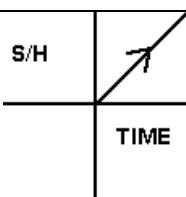
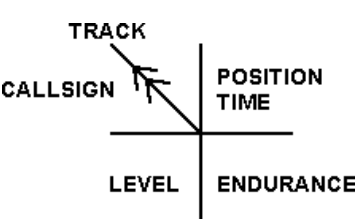
Complete Example: Sailing Boat

Voice	TLX/RTG
<p>MAREC 8/03, RCC AUSTRALIA</p> <p>ALFA, SAILING PART CABIN, FAMILY OF MAN, VICTOR KILO SEVEN FOUR EIGHT TWO, OFF SHORE RACING</p> <p>BRAVO, MAKE PETERSON FOUR ZERO, SAIL MARKINGS SIERRA ONE ONE</p> <p>CHARLIE, MASTHEAD SLOOP RIG</p> <p>DELTA, CARVEL, WOOD, BLACK WITH WHITE CABIN</p> <p>ECHO, FALLING STEM, NEGATIVE TRANSOM STERN</p> <p>FOXTROT, KEEL</p> <p>GOLF, EIGHT METRES</p> <p>HOTEL, PULPIT FORWARD</p> <p>INDIA, TWO</p>	<p>MAREC 8/03, RCC AUSTRALIA</p> <p>A/SAILPC/ FAMILY OF MAN/NAVIS 12/PLEASURE</p> <p>B/PETERSON 40/S 11</p> <p>C/SLOOP</p> <p>D/CARVEL/WOOD/BLACK WITH WHITE CABIN</p> <p>E/FALL/NTRANS</p> <p>F/KEEL</p> <p>G/LOA 8</p> <p>H/PULPIT FORWARD</p> <p>I/2</p>



Figure D-2:15 Sailing Boat

Appendix D-3 Plotting Symbols

Symbol	Description
	Heading and TAS
	Track and ground speed
	Wind velocity
	Position line
	Transferred position line
	Average position line
	Air position
	Dead reckoning position
	Most probable position (MPP)
	Fix (position line)
	Fix (Other than position line – RADAR, GPS etc.)
	Visual fix (pinpoint)
	Ship position
	Sighting and Hearing Reports red - probable black - all other sighting and hearing reports
	Aircraft position

Appendices

Appendix D-4 Sighting and Hearing (SHR) Techniques

Listening Techniques

It is important when questioning an individual either in person or over the phone to actively listen to the information being provided. Practice the following listening techniques when questioning an individual during a SAR incident.

- a) Put the individual at ease;
- b) Remove distractions: don't doodle, tap or shuffle paper;
- c) Empathise with the individual: attempt to see the other person's point of view;
- d) Be patient: allow plenty of time and don't interrupt;
- e) Ask questions: this encourages the individual and shows that you're listening; and
- f) Stop talking: you can't listen if you're talking.

Open Questions

Open questions are a good way to question an individual. Open questions avoid influencing or guiding the individual in their answer. This ensures the integrity of the answers given.

For example: What was the colour of the aircraft you saw?

Open questions usually begin with:

- a) How;
- b) Where;
- c) When;
- d) What;
- e) Who; or
- f) Why.

Closed Questions

Closed questions follow on from an open question, helping to refine the information already given. They usually require a yes or no answer and are good for gaining information quickly.

For example: Are you saying the colour of the aircraft was white?

The closed question usually begins with:

- a) Do;
- b) Is;
- c) Are;
- d) Can; or
- e) Have.

Leading Questions

The problem with leading questions is that they can elicit unreliable information. The individual being questioned may tell you what they think you want to hear.

For example:

Do not ask: *'You say you saw an aircraft. Was it white with a red tail?'*

Ask: *'You say you saw an aircraft. What colour was it?'*

Instructions for Completing Sighting and Hearing Reports

The objective of the Sighting or Hearing Report is to obtain the maximum information available from an observer at the initial contact.

The following points assist persons untrained in SAR to correctly complete the Sighting and Hearing Report:

- a) When taking a call, introduce yourself with your organisation such as 'Australian Search and Rescue'.
- b) Establish follow-up by first obtaining a call back number and the person's availability.
- c) Print CLEARLY on the Sighting or Hearing Report.
- d) Number each report by referral to the Sighting and Hearing Log.
- e) If you find that a component of the report is important, put the caller on hold and obtain the attention of the Intelligence Officer. Use your initiative.
- f) Time. Be cautious: use local time only. This is very critical: try to narrow down an exact time. Record how the time was assessed. If the operation is in an area near a State or Territory border, be mindful of time changes. Also be aware of Daylight-Saving Time.
- g) target location. Attempt to obtain as much detail as possible. If necessary, ask pointed questions. Height may be 'low', 'well above the hills', 'just above the trees'.
- h) Remarks. Be on the lookout for key words. Words like 'slow' can help to assess a report.
- i) Target description. For aircraft searches, the broadcast is normally a little vague and you must be likewise. For example, do not ask if the aircraft was a high-wing aircraft, as the caller may tend to agree with you.
- j) Weather. Obtain accurate reports of cloud, rain, and fog. Most people will report wind speed as 'light' or 'strong'. Direction may be only known as 'north'.
- k) Other witnesses. Obtain full details and interview these separately. This may help to verify parts of another report.
- l) Reliability. Annotate only if this is obvious, for example, whether the person reporting was a police officer or an intoxicated person.
- m) Final check. Check the entire form before hanging up. Ensure the form is SIGNED, DATED and your NAME IS PRINTED.

Sighting and/or Hearing Report for Missing Aircraft

SAR INCIDENT NUMBER	/
---------------------------	---------

OBSERVER AND LOCATION DETAILS

Sighting or Hearing	Reported by	Address	Phone
Time (6 figure) LOCAL UTC	How determined	Observer's location	
Location of Aircraft from Observer			
Aircraft Heading	Aircraft Height	Mode of operation (Level, Climbing etc.)	
REMARKS (Engine Noise, Erratic Behaviour, Smoke, Circling etc)			

DESCRIPTION OF AIRCRAFT AND WEATHER

AIRCRAFT

Aircraft Colours		Aircraft Markings	
Number of engines	Wing position	Tail	Undercarriage (Up or Down)

WEATHER

Wind	Visibility	Cloud	General conditions
------	------------	-------	--------------------

OTHER WITNESSES

Name	Address	Phone
Name	Address	Phone

RCC ASSESSMENT

Assessment and Comment (NOTE: Ask Reporter to phone again if additional detail is recalled)			
REPORT TAKEN BY		DTG of Report (6 figure) UTC	
Intelligence Officer	Plotted	Recorder	Other

Page ____ of ____

Sighting and Hearing Report – Generic

Observer/Asset Location (Complete all mandatory fields)										
Name/Callsign ** Location Name Location Coordinates Remarks	Phone **									
	S	E	Uncertainty		(Kms)					
	Remarks									
	Observed Object Position									
Position Location Coordinates ** DTG ** Remarks	S			E		Uncertainty		(Kms)		
	DTG **		<input type="checkbox"/> UTC / <input type="checkbox"/> Local		Uncertainty		(Mins)			
	Remarks									
	Description (Select the relevant checkboxes)									
Report Type	<input type="checkbox"/> Sighted	Type	<input type="checkbox"/> Vessel	<input type="checkbox"/> Aircraft	<input type="checkbox"/> Vehicle	<input type="checkbox"/> Heard	<input type="checkbox"/> Person	<input type="checkbox"/> Signal	<input type="checkbox"/> Other	<input type="checkbox"/> Pollution
Remarks										
Weather (Complete the details using the laminated Pick List)										
Other Witnesses										
Name	Phone	S/H Report Completed?		Notes						
		<input type="checkbox"/> Yes / <input type="checkbox"/> No								
		<input type="checkbox"/> Yes / <input type="checkbox"/> No								
		<input type="checkbox"/> Yes / <input type="checkbox"/> No								
Assessment										
Incident Number **										
Priority	<input type="checkbox"/> Priority	Assessment	<input type="checkbox"/> Unassessed	<input type="checkbox"/> Possible	<input type="checkbox"/> Definite					
	<input type="checkbox"/> Routine		<input type="checkbox"/> Negative	<input type="checkbox"/> Other						
Annotation										
Note										
Admin										
Report Taken By				Hardcopy S/H No						
Report Taken @				Electronic ID No						

** Mandatory Fields

Appendices

Appendix D-5 Tables and Graphs

Overview

Local Wind Current

Figure D-5:1 Local Wind Current Graph

Leeway Tables (kt)

Table D-5:1 Leeway Speed and Direction Values for Drift Objects

Table D-5:2 Sub-Table for Maritime Life Rafts with Deep Ballast Systems and Canopies

Sweep Width Tables for Visual Search Over Water

Table D-5:3 Uncorrected Visual Sweep Width for Vessels and Small Boats

Table D-5:4 Weather Correction Factors for All Types of Search Facilities

Table D-5:5 Uncorrected Visual Sweep Widths for Merchant Ships [Km (NM)]

Table D-5:6 (1) Uncorrected Sweep Widths for Fixed-Wing Aircraft (NM) at 500 feet and 1000 feet

Table D-5:6 (2) Uncorrected Sweep Widths for Fixed-Wing Aircraft (NM) 1500 feet and 2000 feet

Table D-5:7 (1) Uncorrected Sweep Widths for Helicopters (NM) – Maritime 500 feet and 1000 feet

Table D-5:7 (2) Uncorrected Sweep Widths for Helicopters (NM) – Maritime 1500 feet and 2000 feet

Table D-5:8 Speed (velocity) Correction Factors for Helicopter and Fixed-Wing Aircraft Search Facilities

Sweep Width Tables for Visual Search Over Land:

Table D-5:9 Uncorrected Sweep Widths for Visual Land Search [Km (NM)]

Table D-5:10 Correction Factors – Vegetation and High Terrain

Probability of Detection

Figure D-5:13 Probability of Detection Graph

Local Wind Current

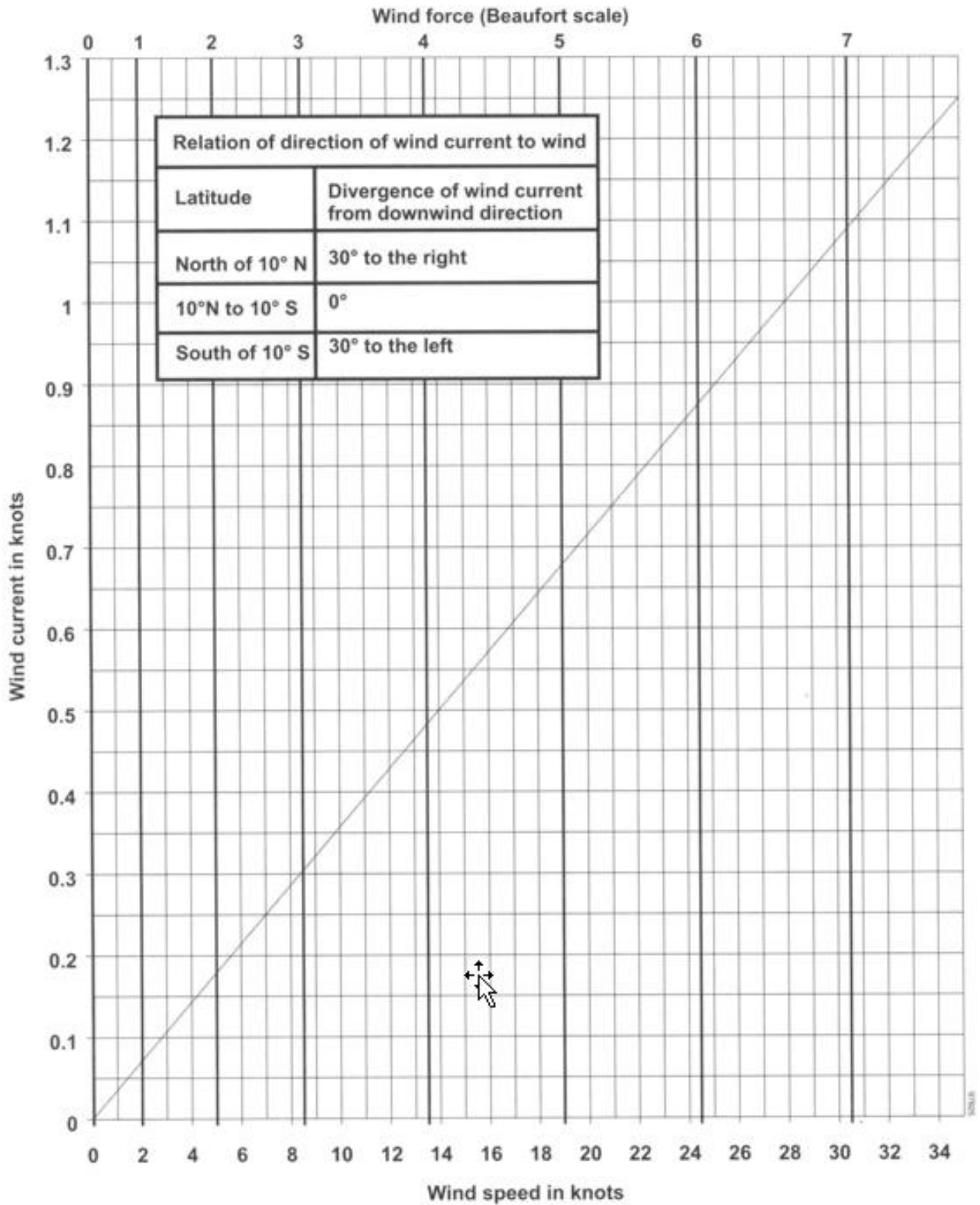


Figure D-5:1 Local Wind Current Graph

Leeway Tables (kt)

Leeway Target Class				Leeway Speed		Divergence	
Category	Subcategories	Primary Leeway Descriptors	Secondary Leeway Descriptors	Multiplier	Modifier (kt)	Angle (deg)	
PIW				0.011	0.07	30	
	Vertical			0.005	0.07	18	
	Sitting			0.012	0.00	18	
	Horizontal	Survival Suit		0.014	0.10	30	
		Scuba Suit		0.007	0.08	30	
		Deceased		0.015	0.08	30	
Survival Craft	Maritime Life Rafts	No Ballast Systems	no canopy, no drogue	0.042	0.03	28	
			no canopy, w/ drogue	0.057	0.21	24	
			canopy, no drogue	0.044	-0.20	28	
			canopy, w/ drogue	0.037	0.11	24	
		Shallow Ballast Systems and Canopy		0.030	0.00	28	
			no drogue	0.029	0.00	22	
			with drogue	0.032	-0.02	22	
			Capsized	0.025	0.01	22	
	Deep Ballast Systems & Canopies	(See Table I-2 for Levels 4-6)	0.017	-0.10	8		
			0.030	0.02	13		
	Other Maritime Survival Craft	life capsule			0.038	-0.08	22
		USCG Sea Rescue Kit			0.025	-0.04	7
Aviation Life Rafts	no ballast, w/canopy Evac/ Slide	4-6 person, w/o drogue	0.037	0.11	24		
		46-person	0.028	-0.01	15		
Person-Powered Craft	Sea Kayak	W/ Person on aft deck		0.011	0.24	15	
	Surfboard	w/ person		0.020	0.00	15	
	Windsurfer	w/ person and mast & sail in water		0.023	0.10	12	
Sailing Vessels	Mono-hull	Full Keel	Deep Draft	0.030	0.00	48	
		Fin Keel	Shoal Draft	0.040	0.00	48	
Power Vessels	Skiffs	Flat Bottom	Boston whaler	0.034	0.04	22	
		V-hull	Std. Configuration.	0.030	0.08	15	
			Swamped	0.017	0.00	15	
	Sport Boats	Cuddy Cabin	Modified V-hull	0.069	-0.08	19	
	Sport Fisher	Centre Console	Open cockpit	0.060	-0.09	22	
Power Vessels	Commercial Fishing Vessels	Sampans		0.037	0.02	48	
		Side-stern Trawler		0.040	0.00	48	
		Longliners		0.042	0.00	48	
		Junk		0.037	0.00	48	
		Gill-netter	w/rear reel	0.027	0.10	48	
			0.040	0.01	33		
	Coastal Freighter			0.028	0.00	48	
Boating Debris	F/V debris			0.020	0.00	10	
	Bait/wharf box holds a cubic meter of ice	lightly loaded		0.013	0.27	31	
		fully loaded		0.026	0.18	15	
				0.016	0.16	33	

Table D-5:1 Leeway Speed and Direction Values for Drift Objects (kt)

Appendices

Leeway Target Class				Leeway Speed		Divergence	
Secondary Leeway Descriptors	Capacity Modifier	Drogue Modifier	Loading Modifier	Multiplier	Modifier (Kts)	Angle (Deg)	
Maritime Life Rafts with Deep Ballast Systems and Canopies	4-6 person capacity	without drogue		0.029	0.04	15	
			light loading	0.038	-0.04	15	
			heavy loading	0.038	-0.04	15	
		with drogue		0.018	0.03	12	
			light loading	0.016	0.05	24	
			heavy loading	0.021	0.00	20	
	15-25 person capacity			0.036	-0.09	10	
		without drogue	light loading	0.039	-0.06	9	
		with drogue	heavy loading	0.031	-0.07	9	
	Capsized				0.009	0.00	12
	Swamped				0.010	-0.04	8

Table D-5:2 Sub-Table for Maritime Life Rafts with Deep Ballast Systems and Canopies (kt)

Notes:

1. These tables are adapted from Allen and Plourde 1999 Review of Leeway: Field Experiments and Implementation. USCG Research and Development Centre Report No CG-D-08-99.
2. Prior to the publication of the data the USCG Research and Development Centre made the decision that the only data published would be data that was based on actual results derived from documented research and observation during controlled field experiments. However, it has been recognised that some anomalies exist in the data pertaining to maritime life rafts with no ballast systems. There had been significant time between the initial research done by Hufford and Broida in 1974 and later research by Nash and Willcox in 1991. Also, it is probable that the make of life raft used for the experiments may no longer be in use.
3. SMCs should evaluate the calculated results obtained from using the tables with actual known conditions and adjust leeway values as appropriate.

Taxonomy Class Definitions/Descriptions

The following section provides information about each of the leeway drift objects in Table D-5:1. For each description, the target characteristics are summarised, and pictures are provided where available. These target descriptions are in no way meant to be all-inclusive. They are intended to assist a search planner in target identification. Proper identification will make the application of more specific leeway values possible. Some categories in Table D-5:1 do not require further explanation and therefore descriptions/pictures are not included. The SAR planner should also be reminded that any classification system will have overlap between some categories. In these cases, a decision must be made about the most probable situation.

- a) **Person-in-Water (PIW)**
- b) **Persons in water** including persons without any floatation, and those with a throwable cushion, with a PFD, in an anti-exposure suit and in survival/immersion suits

-
- i) **Vertical**

Generally, requires a conscious and active PIW to maintain this position. A PIW wearing a sport/work vest, anti-exposure suit, or float coat or having no flotation must actively maintain a vertical position in the water or become victims in the horizontal position
 - ii) **Sitting**

The classic foetal position with legs drawn up and arms huddled across the PFD. This is the preferred position a conscious or unconscious person assumes, especially in cold water, when wearing offshore lifejackets, horse-collar lifejackets, or inflatable vests. A conscious PIW hanging onto a throwable device will also assume the sitting position until he become unconscious at which time he become a victim.
 - iii) **Horizontal**

Three separate configurations place the PIW in a horizontal position. A conscious or unconscious PIW wearing a survival suit will float flat on his back. A PIW in scuba gear, with an inflated buoyancy vest, will float in a semi-reclined position. The classic floating position of a victim is floating face down in the water.
 - c) **Maritime Survival Craft**

This section includes life rafts, lifeboats, and life capsules as illustrated at Figure D-5:2. It does not include dinghies or inflatable boats that may be carried for the same purpose.
 - i) **Maritime Life Rafts**

If there is any question about what type of life raft a vessel may carry, a phone call to life raft repair and repackaging facilities close to the homeport of the distressed vessel may provide ballast, canopy, size, and drogue information.
 - ii) **Shallow Ballast**

Consists of a series of fabric pockets generally four (4) inches in diameter and less than six inches in depth.
 - iii) **Deep Ballast**

Consist of large fabric bags, from three (3)–seven (7) on the raft, that are at least 1' x 2' x 2'.
 - d) **Other Maritime Survival Craft** - i) **Life Capsule**

Fully enclosed crafts commonly used on large merchant and military vessels.
 - e) **Aviation Life Rafts**

Fall basically into two groups, life rafts and slide rafts. Aviation life rafts are similar to marine life rafts but are usually made from lighter materials.
 - i) **Evacuation/Slide**

Slide rafts are specifically designed devices intended to ease evacuation from an aircraft. They mount to doorframes or near wing emergency exits and are cut loose from the airframe once fully loaded.
 - f) **Person-Powered Craft**

This description includes all forms of rowed or paddled boats including rowboats, inflatable boats without motors, canoes, kayaks, stand up paddle boards, surfboards and windsurfers.

For examples, see Figure D-5:3.

g) **Mono-hull Sailing Vessel**

It is assumed that all targets in this category are adrift; therefore, sails are down or missing and the crew is unable to manoeuvre the vessel at all. A class of small to medium sized sailing vessels generally less than 20 ft and never more than 30 ft in length, they are typically designed for a single purpose such as racing or day sailing.

i) **Full Keel**

Small to medium sized sailboats whose keel runs the full length or nearly the full length of the hull. While the forward portion of the keel is modified or eliminated on some full keel sailboats, the keel on all full keel sailboats extends aft to the rudder. This is an old hull design and is not commonly used in new hull construction due to the relatively slow sailing speeds of this hull design.

ii) **Fin Keel**

Small to medium sized sailboats with permanent keel skegs that do not extend aft to the rudder.

h) **Skiffs**

Open boats less than 20 ft long that use an outboard motor as the primary source of propulsion. Some have characteristics identical to rowed boats with the exception that an outboard motor has been attached to the stern. This group includes, but is not limited to, tenders for larger vessels, bass boats, hunting boats, Jon boats, and a large category of utility boats. Skiffs are usually found on lakes and rivers but are also common in the calm waters of many bays and rivers that provide access to the open ocean.

i) **Personal Water Craft**

Include a number of different designs for one or more persons. Generally, there are stand up models and ride on models. Some craft marketed as PWC closely resemble small sport boats. Most PWC's have water jet propulsion. No leeway drift experiments have yet been performed on PWC's and they do not appear within Table D-5-1. Leeway category choice should be based on number of passengers / loading, size of PWC (draft, length, freeboard) of PWC. These factors may be comparable (not exactly) to several other leeway targets.

j) **Sport Boats**

Includes pleasure craft from 15 to 28 feet long with beamwidths from roughly 6 to 9 feet.

They include metal, fibreglass, and wood vessels with a V, modified-V, or deep-V hull form. Sport boats can be outfitted with inboard, outboard, or I/O propulsion. This category includes side console (closed bow and bow riders) and cuddy cabin boats. (Figure D-5:8)

k) **Sport Fisher**

Include pleasure and commercial craft from 17 to approximately 100 feet long with beam widths up to 24 ft. The majority are between 30 and 50 ft long, with beam widths between 10 and 15 ft. This class includes both semi-displacement and planning hull forms that can be outfitted with inboard, outboard, or I/O propulsion. This category includes boats with simple centre console or walk-round cabin. Convertibles are sport fishers with a walk around cabin and flying bridge. Convertibles designed for offshore fishing may also have a spotting tower. Many convertibles provide extended cruising capabilities similar to sport cruisers, but their after-deck design provides a larger open area to work fishing gear. Some of these vessels can also be found in the cruiser or motor yacht categories. (Figure D-5:9)

l) **Multi-hulled vessels**

Multi-hulled vessels: these vessels differ from monohulls in that they have either two similar sized parallel hulls or a larger centre hull with two smaller ones on either beam. These vessels range in size from small hobby vessels of 4-5m in length to ferries and tourist vessels. All but the smallest have living quarters in the hulls and possible on the deck that joins them. They can be sail or motor

driven, or a combination of both. There is no current separate category in the leeway tables for vessels of this style. (Figure D-5:10)

m) **Commercial Fishing Vessels**

Include vessels from 45 to 100 feet long designed for fishing or shell fishing in coastal and ocean waters. They include side and stern trawling rigs, long liners, bottom dragging rigs, and purse seiners. Pole fishers are simply modified use of a sport fisher or sport cruiser and should be treated as such. Commercial fishers can be working alone, as paired vessels, or can be the mother ship to a group of smaller fishing skiffs. These vessels have different design features based on their purpose, but all have some form of deckhouse and an open area from which nets can lines are worked. A deck winch and boom system are commonly used to handle nets or lines. (Figure D-5:11)

n) **Coastal Freighter**

Include a wide range of commercial shipping platforms up to 100 feet in length. These vessels transfer cargo from one port to another, and shipping agents can provide estimated voyage schedules. Coastal freighters include vessels with a deckhouse on the forecastle, a midships deckhouse (common to cargo vessels), and an aft deckhouse (common to tankers and container ships). Leeway of these vessels will of course not only vary with respect to deckhouse location; it will also be greatly affected by loading, amount, and type of cargo. (Figure D-5:12)

o) **Boating Debris**

Includes any debris that can be expected from a boat that is sinking and/or breaking up. It may include paper or plastic containers, bedding or clothing, and a variety of fragmented boat sections.

i) **Fishing Debris**

Debris typical to a fishing vessel such as lifejacket, life ring, fishing float balls, a fishing box lid, or wooden boards

ii) **Bait/Wharf Box**

Commercially available 1.1 X 1.5 metre plastic box used by commercial fisherman for holding ice and/or fish. Although not it's intended use, it could also serve as a floatation/life raft by persons in distress.

- **Lightly loaded.** Approximately 200 lbs / 90.7 kg. (simulation of one person)
- **Fully loaded.** Approximately 800 lbs / 362.8 kg. (simulation of four persons)

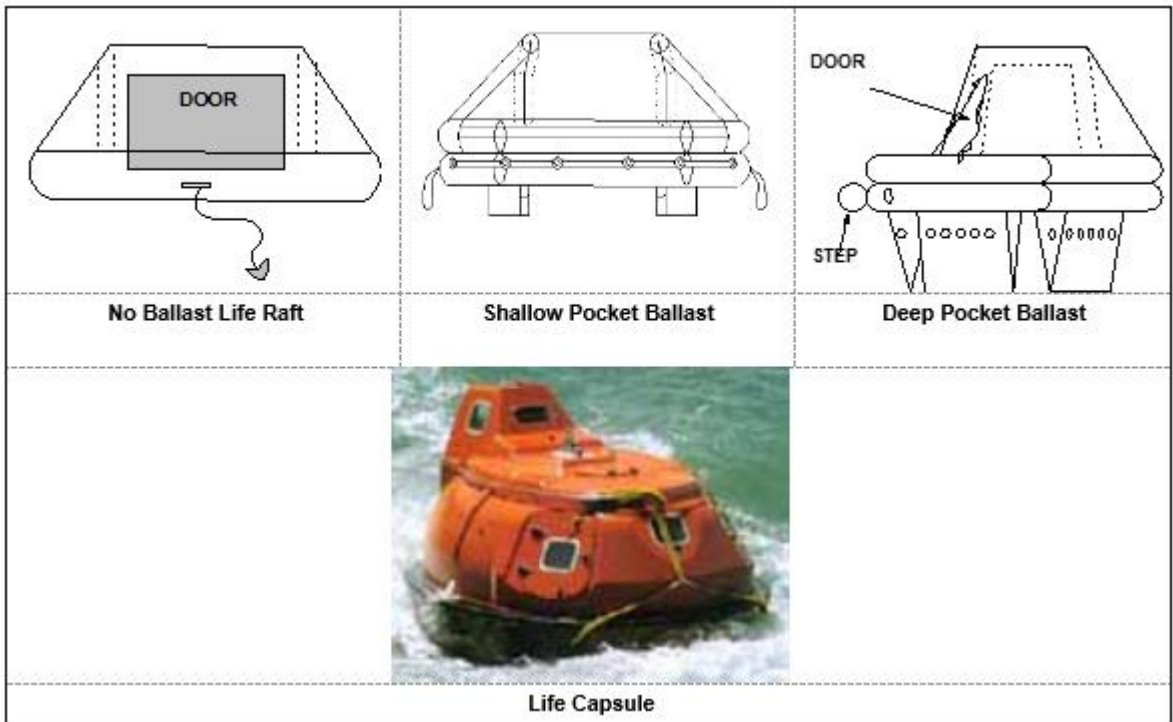


Figure D-5:2 Maritime Survival Craft

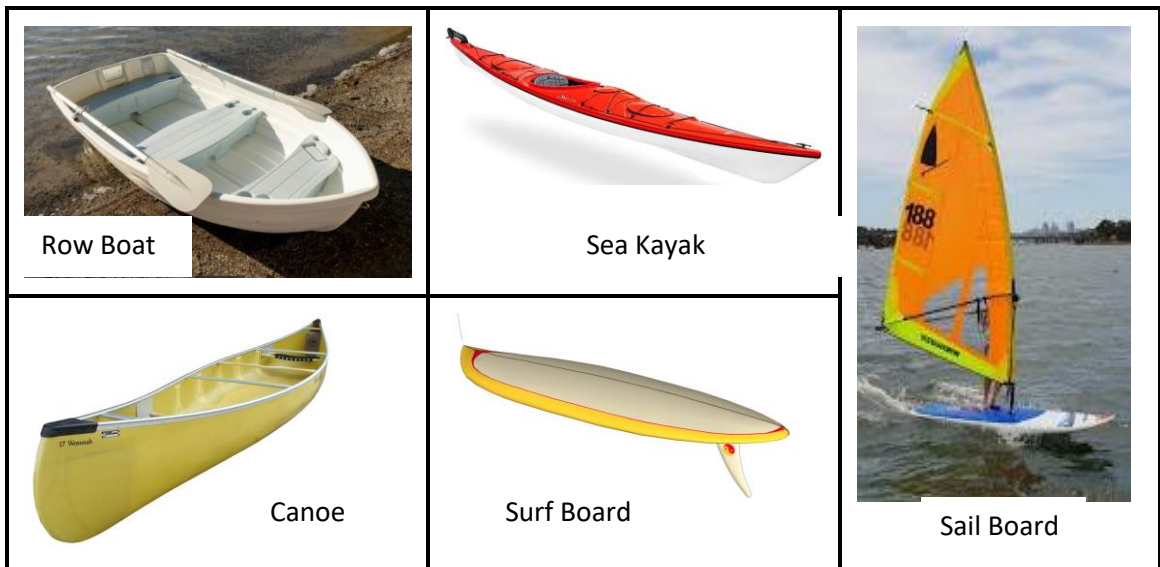


Figure D-5:3 Person-Powered Craft

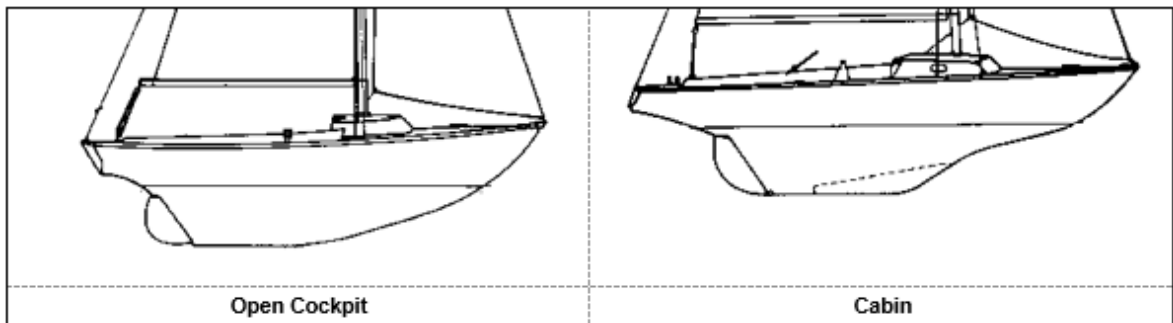


Figure D-5:4 Full Keel One Design Sailboat

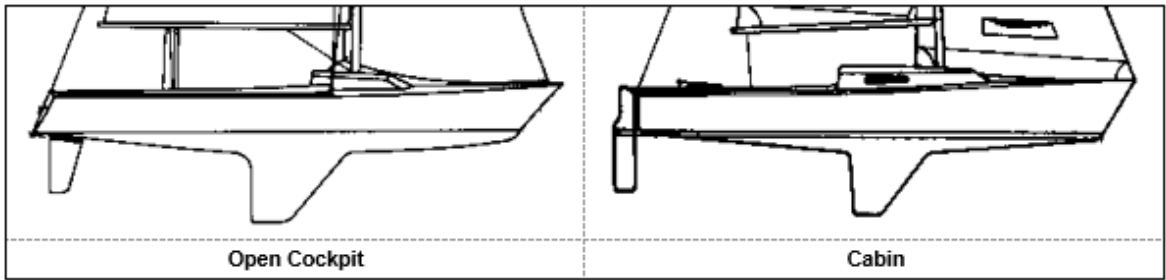


Figure D-5:5 16 Dagger Keel One-Design Sailboat

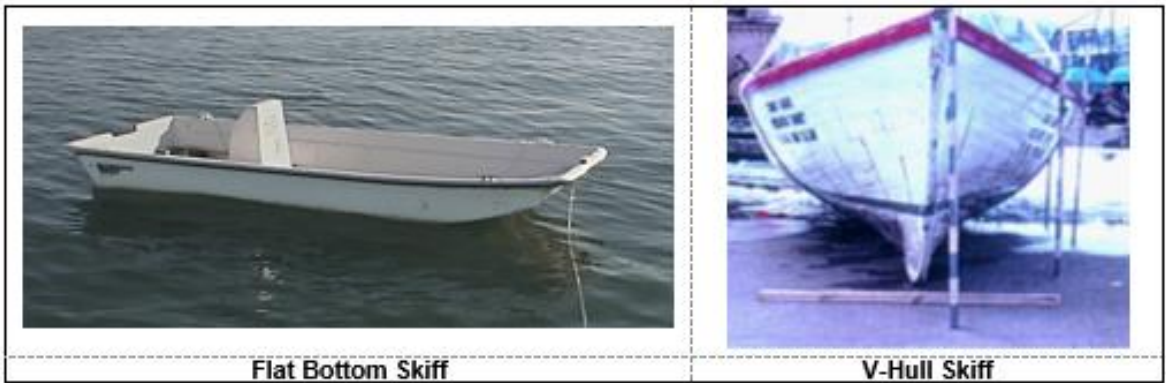


Figure D-5:6 Skiffs

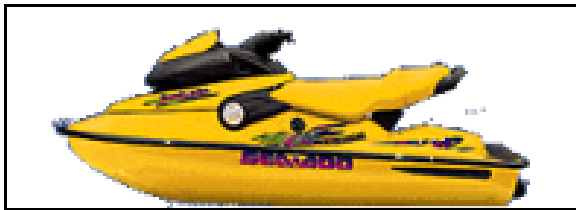


Figure D-5:7 Personal Water Craft

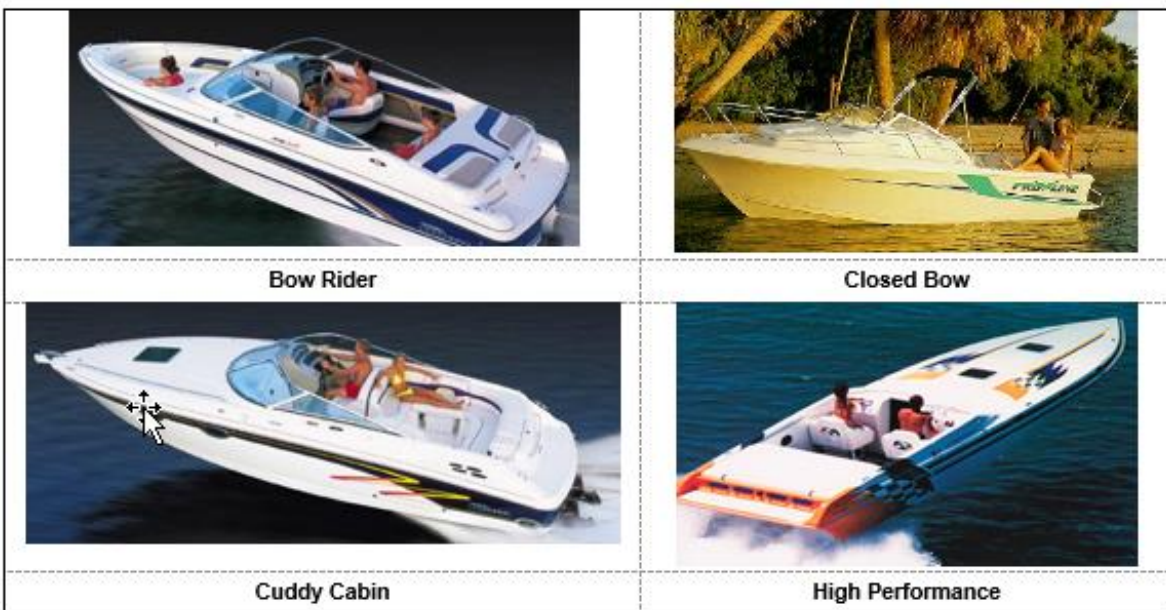


Figure D-5:8 Sports Boats

Appendices

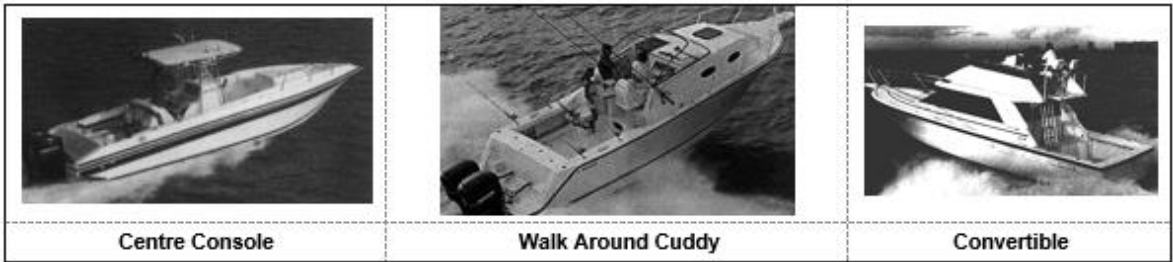


Figure D-5:9 Sport Fishers



Figure D-5:10 Multi-hulled vessels

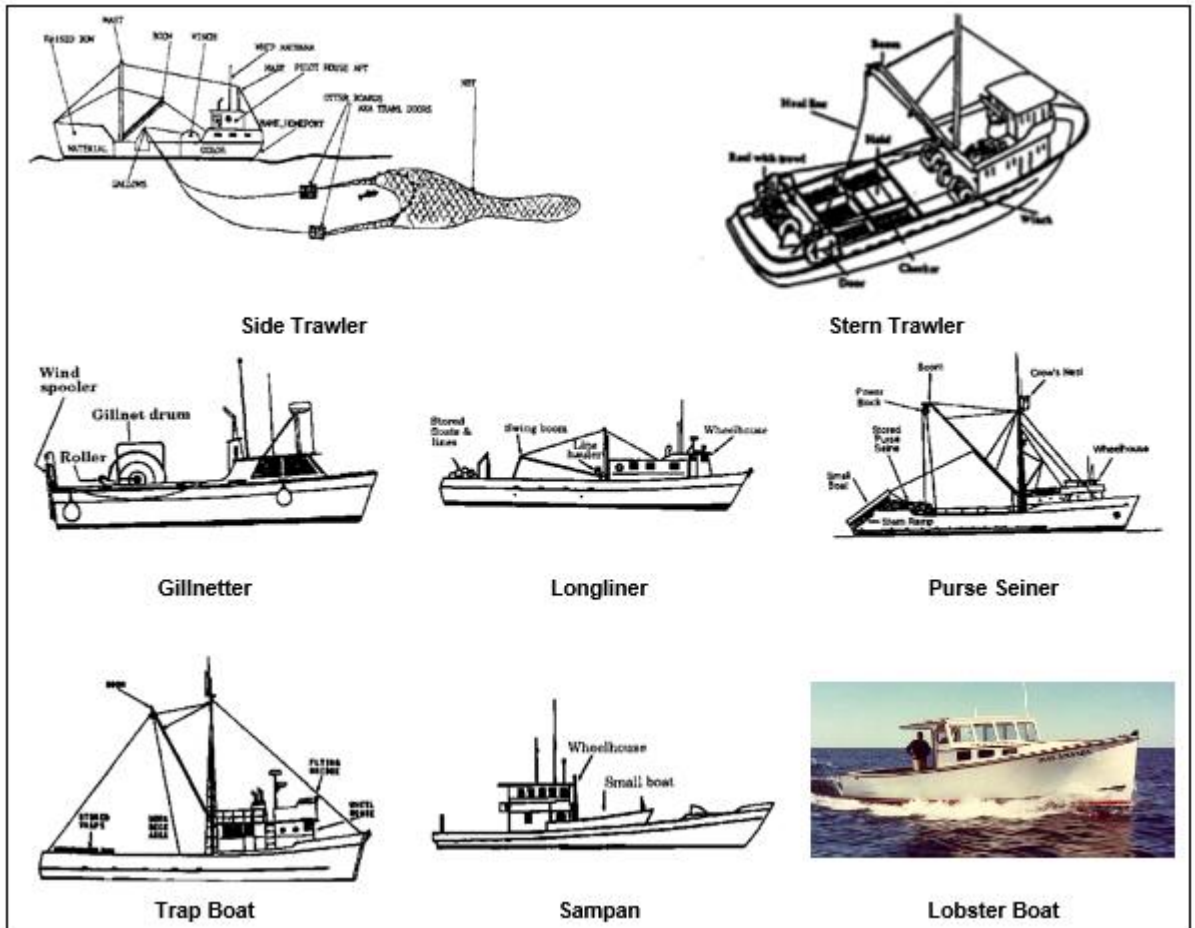


Figure D-5:11 Commercial Fishers

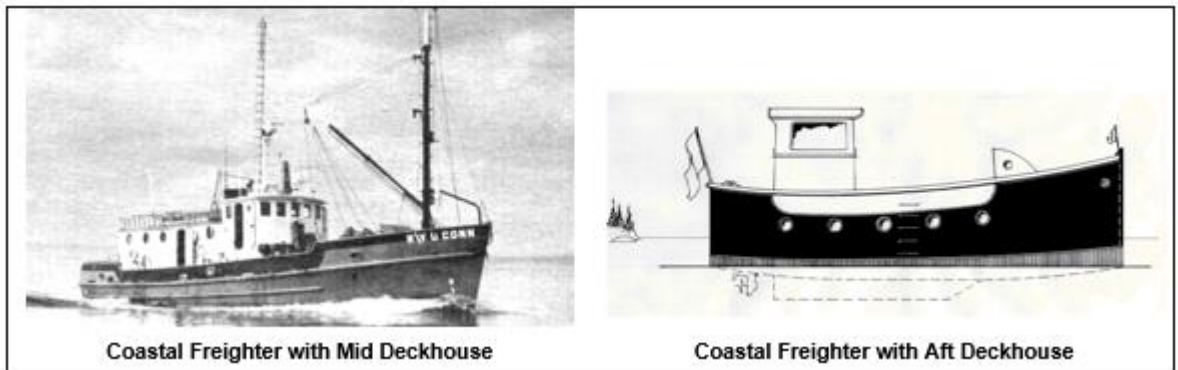


Figure D-5:12 Coastal Freighters

Appendices

Probability of Detection

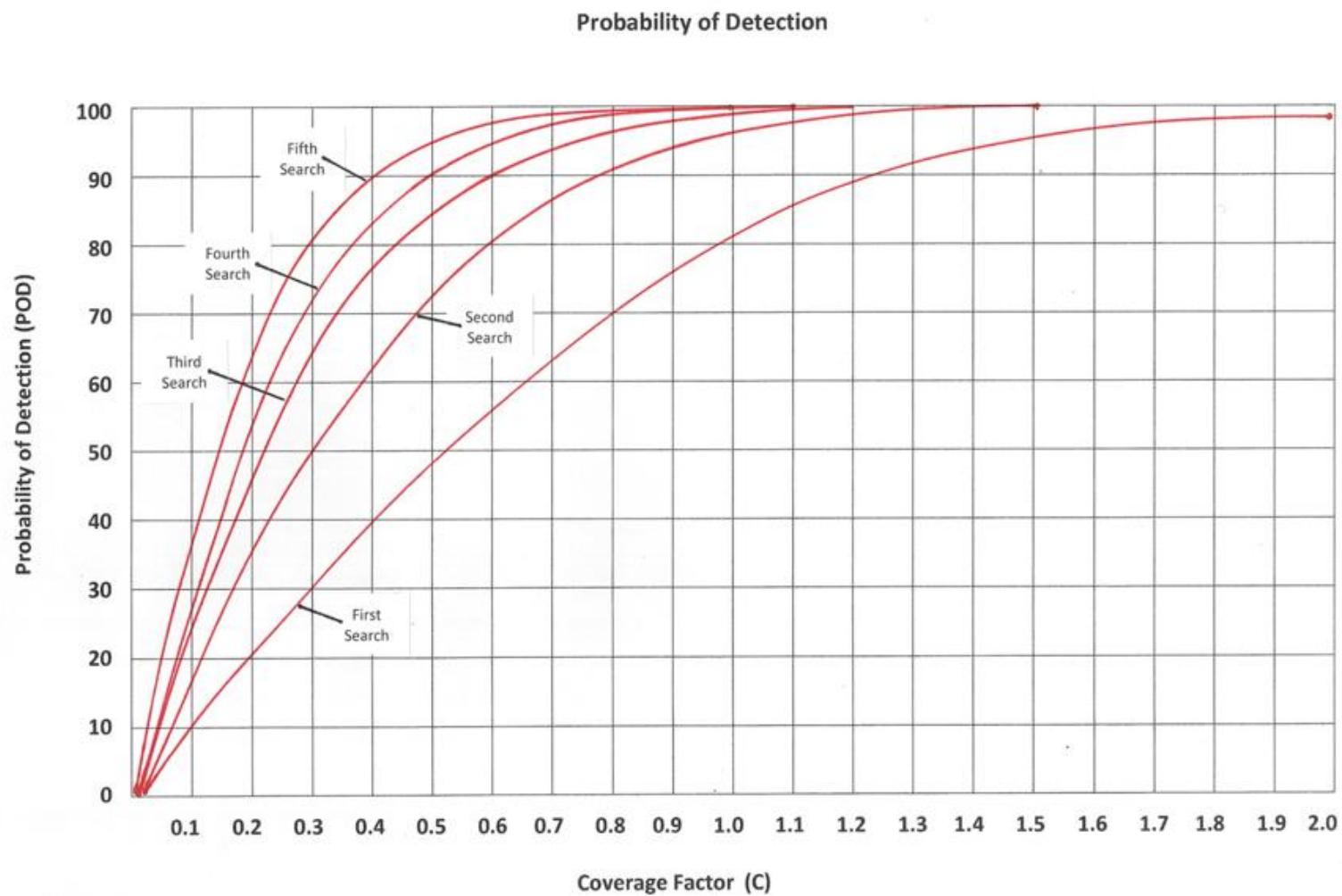


Figure D-5:13 Probability of Detection

Sweep Widths and Correction Factors

Sweep Width Tables for Visual Search over Water

SEARCH OBJECT	Height of eye 8'						Height of eye 14'					
	Visibility in kilometres/NM						Visibility in kilometres/NM					
	2/ 1.1	5/ 2.7	10/ 5.4	15/ 8.1	20/ 10.8	>25/ 13.5	2/ 1.1	5/ 2.7	10/ 5.4	15/ 8.1	20/ 10.8	>25/ 13.5
Person in water	0.2	0.2	0.3	0.3	0.3	0.3	0.3	0.4	0.5	0.6	0.6	0.6
Raft 1 Person	0.7	1.2	1.8	2.1	2.4	2.5	1.0	1.6	2.5	2.9	3.2	3.3
Raft 4 Person	0.8	1.5	2.3	2.9	3.2	3.4	1.1	2.0	3.1	3.8	4.2	4.4
Raft 6 Person	0.9	1.7	2.7	3.4	3.8	4.1	1.2	2.2	3.5	4.4	5.0	5.3
Raft 8 Person	0.9	1.7	2.8	3.5	4.0	4.2	1.2	2.3	3.6	4.5	5.1	5.4
Raft 10 person	0.9	1.8	2.9	3.7	4.2	4.6	1.2	2.3	3.7	4.7	5.4	5.8
Raft 15 Person	1.0	2.0	3.2	4.0	4.5	4.9	1.2	2.5	4.0	5.1	5.7	6.2
Raft 20 Person	1.0	2.1	3.5	4.4	5.1	5.6	1.3	2.6	4.3	5.7	6.4	6.9
Raft 25 Person	1.0	2.2	3.7	4.7	5.5	6.0	1.3	2.7	4.3	5.8	6.7	7.5
Power Boat <5 m (15 ft)	0.5	0.7	1.0	1.2	1.3	1.4	0.5	1.0	1.5	1.8	1.9	2.0
Power Boat 5-8 m (15-25 ft)	0.8	1.4	2.3	2.9	3.4	3.8	1.0	1.9	3.0	3.9	4.5	5.0
Power Boat 8-12 m (25-40 ft)	0.8	1.8	3.1	4.1	4.9	5.6	1.2	2.3	4.0	5.3	6.4	7.3
Power Boat 12-20 m (40-65 ft)	0.9	2.2	4.2	5.9	7.4	8.7	1.2	3.0	5.4	7.6	9.6	11.3
Power Boat 20-27 m (65-90 ft)	0.9	2.3	4.6	6.8	8.8	10.6	1.2	3.0	6.0	8.7	11.3	13.6
Sail Boat 5 m (15 ft)	0.8	1.4	2.2	2.7	3.1	3.4	1.0	1.8	2.8	3.5	4.1	4.5
Sail Boat 6 m (20 ft)	0.8	1.6	2.6	3.3	3.9	4.4	1.1	2.0	3.3	4.3	5.0	5.6
Sail Boat 8 m (25 ft)	0.9	1.8	2.9	3.9	4.6	5.1	1.1	2.2	3.8	5.0	5.9	6.7
Sail Boat 9 m (30 ft)	0.9	2.0	3.4	4.6	5.5	6.3	1.2	2.5	4.4	5.9	7.1	8.1
Sail Boat 12 m (40 ft)	0.9	2.2	4.1	5.7	7.0	8.1	1.3	2.8	5.2	7.2	9.0	10.5
Sail Boat 15 m (50 ft)	0.9	2.2	4.3	6.1	7.7	9.1	1.2	2.9	5.2	7.9	9.9	11.7
Sail Boat 20-23 m (65-75 ft)	0.9	2.3	4.5	6.5	8.3	9.9	1.2	3.0	5.8	8.4	10.8	12.9
Sail Boat 23-27 m (75-90 ft)	0.9	2.4	4.7	6.8	8.9	10.7	1.2	3.1	6.1	8.9	11.5	13.8

Table D-5:3 Uncorrected Visual Sweep Width for Vessels and Small Boats (NM)

Note: A sailboat is only a sailboat if the sails are up. If the sails are down, the craft should be classed as a powerboat.

Weather Correction Factors for all Types of Search Facilities

Weather: Winds Km/h (kt) or seas m (ft)	Search Object	
	Person in water, raft or boat <10 m (33 ft)	Other search objects
Winds <28 Km/h (<15 kts) or seas 0-1 m (0-3 ft)	1.0	1.0
Winds 28-46 Km/h (15-25 kts) or seas 1-1.5 m (3-5 ft)	0.5	0.8
Winds >46 Km/h (>25 kts) or seas >1.5 m (>5 ft)	0.25	0.5

Table D-5:4 Weather Correction Factors for all Types of Search Facilities

Note: This table differs from IAMSAR for other search objects in winds greater than 15 kts. This is based on previous values used and observations of the reported effects of high winds on sweep width values in actual SAR incidents.

Uncorrected Visual Sweep Widths for Merchant Ships (NM)

Height of eye correlates to bridge of a merchant ship	Meteorological visibility [Km]				
	5 Km	10 Km	20 Km	30 Km	40 Km
Search Object					
Person in water	0.4	0.5	0.6	0.7	0.7
4-person life raft	2.3	3.2	4.2	4.9	5.5
6-person life raft	2.5	3.6	5.0	6.2	6.9
15-person life raft	2.6	4.0	5.1	6.4	7.3
25-person life raft	2.7	4.2	5.2	6.5	7.5
Boat <5 m (17 ft)	1.1	1.4	1.9	2.1	2.3
Boat <7 m (23 ft)	2.0	2.9	4.3	5.2	5.8
Boat <12 m (40 ft)	2.8	4.5	7.6	9.4	11.6
Boat <24 m (79 ft)	3.2	5.6	10.7	14.7	18.1

Table D-5:5 Uncorrected Visual Sweep Widths for Merchant Ships (NM)

This page has intentionally been left blank

Uncorrected Sweep Widths for Fixed-Wing Aircraft (NM) at 500 ft and 1000 ft

Search Object	Altitude 500 (ft)						Altitude 1000 (ft)					
	Visibility Km/NM						Visibility Km/NM					
	2/ 1.1	5/ 2.7	10/ 5.4	20/ 10.8	30/ 16.2	>40/ 21.6	2/ 1.1	5/ 2.7	10/ 5.4	20/ 10.8	30/ 16.2	>40/ 21.6
Person in water	0.0	0.1	0.1	0.1	0.1	0.1	0.0	0.1	0.1	0.1	0.1	0.1
Raft 1 person	0.3	0.7	0.9	1.2	1.4	1.4	0.3	0.7	0.9	1.2	1.4	1.4
Raft 4 Person	0.4	1.0	1.3	1.8	2.0	2.2	0.3	1.0	1.3	1.8	2.1	2.3
Raft 6 Person	0.4	1.1	1.5	2.2	2.5	2.8	0.4	1.1	1.6	2.2	2.6	2.8
Raft 8 Person	0.4	1.2	1.6	2.3	2.7	2.9	0.4	1.2	1.7	2.4	2.8	3.0
Raft 10 Person	0.4	1.2	1.7	2.5	2.9	3.2	0.4	1.3	1.8	2.6	3.0	3.3
Raft 15 Person	0.5	1.3	1.9	2.7	3.3	3.6	0.4	1.4	2.0	2.8	3.4	3.7
Raft 20 Person	0.5	1.5	2.1	3.2	3.8	4.2	0.4	1.5	2.2	3.2	3.9	4.3
Raft 25 Person	0.5	1.6	2.3	3.4	4.1	4.6	0.4	1.6	2.3	3.5	4.2	4.7
Power Boat <5 m (15 ft)	0.4	0.9	1.2	1.5	1.7	1.8	0.4	1.0	1.3	1.7	1.8	2.0
Power Boat 5-8 m (15-25 ft)	0.5	1.7	2.4	3.6	4.3	4.8	0.5	1.7	2.5	3.7	4.4	5.0
Power Boat 8-12 m (25-40 ft)	0.6	2.1	3.3	5.3	6.7	7.7	0.5	2.2	3.4	5.4	6.8	7.8
Power Boat 12-20 m (40-65 ft)	0.6	2.7	4.5	8.1	10.9	13.1	0.6	2.7	4.5	8.2	10.9	13.1
Power Boat 20-27 m (65-90 ft)	0.6	2.8	5.0	9.8	13.5	16.7	0.6	2.8	5.1	9.8	13.6	16.7
Sail Boat 5 m (15 ft)	0.5	1.6	2.2	3.2	3.9	4.3	0.5	1.6	2.3	3.3	4.0	4.4
Sail Boat 8 m (25 ft)	0.6	2.0	3.1	4.9	6.1	7.0	0.5	2.1	3.2	5.0	6.2	7.1
Sail Boat 12 m (40 ft)	0.6	2.6	4.3	7.6	10.0	11.9	0.6	2.6	4.3	7.6	10.9	12.0
Sail Boat 15 m (50 ft)	0.8	2.7	4.6	8.4	11.3	13.7	0.6	2.7	4.6	8.5	11.4	13.7
Sail Boat 20-23 m (65-75 ft)	0.6	2.8	4.9	9.3	12.7	15.5	0.6	2.8	4.9	9.3	12.8	15.6
Sail Boat 23-27 m (75-90 ft)	0.6	2.8	5.1	9.9	13.7	17.0	0.6	2.8	5.1	9.9	13.6	17.0
Ship 27-46 m (90-150 ft)	0.6	2.9	5.4	11.1	15.9	20.1	0.6	2.9	5.4	11.1	15.9	20.1
Ship 46-91 m (150-300 ft)	0.6	3.0	5.7	12.5	18.9	24.7	0.6	3.0	5.7	12.5	18.9	24.7
Ship >91 m (>300 ft)	0.7	3.0	5.8	13.2	20.6	27.9	0.6	3.0	5.8	13.2	20.6	27.9

Table D-5:6 (1) Uncorrected Sweep Widths for Fixed-Wing Aircraft (NM) at 500 ft and 1000 ft

Notes:

1. For search altitudes of 500 feet only, the sweep width values for a person in water may be multiplied by four (4), if it is known that the person is wearing a flotation device.
2. A sailboat is only a sailboat if the sails are up. If the sails are down, the craft should be classed as a powerboat.

Weather Correction Factors for all Types of Search Facilities

Weather: Winds Km/h (kt) or seas m (ft)	Search Object	
	Person in water, raft or boat <10 m (33 ft)	Other search objects
Winds <28 Km/h (<15 kts) or seas 0-1 m (0-3 ft)	1.0	1.0
Winds 28-46 Km/h (15-25 kts) or seas 1-1.5 m (3-5 ft)	0.5	0.8
Winds >46 Km/h (>25 kts) or seas >1.5 m (>5 ft)	0.25	0.5

Table D-5:4 Weather Correction Factors for all Types of Search Facilities

Note: This table differs from IAMSAR for other search objects in winds greater than 15 kts. This is based on previous values used and observations of the reported effects of high winds on sweep width values in actual SAR incidents.

Uncorrected Sweep Widths for Fixed-Wing Aircraft (NM) at 1500 ft and 2000 ft

Search Object [Metres (ft)]	Altitude 1500 (ft)						Altitude 2000 (ft)					
	Visibility [Km]						Visibility [Km]					
	2	5	10	20	30	>40	2	5	10	20	30	>40
Person in Water	0.0	0.0	0.0	0.0	0.0	0.1	0.0	0.0	0.0	0.0	0.0	0.0
Raft 1 person	0.2	0.7	0.9	1.3	1.4	1.4	0.1	0.6	0.9	1.2	1.4	1.4
Raft 4 person	0.3	1.0	1.3	1.9	2.1	2.3	0.2	0.9	1.3	1.9	2.2	2.3
Raft 6 person	0.3	1.1	1.6	2.3	2.6	2.9	0.2	1.1	1.6	2.3	2.7	2.9
Raft 8 person	0.3	1.2	1.7	2.4	2.8	3.1	0.2	1.2	1.7	2.5	2.9	3.2
Raft 10 person	0.3	1.3	1.8	2.6	3.1	3.4	0.2	1.2	1.8	2.7	3.1	3.5
Raft 15 person	0.3	1.4	2.0	2.9	3.4	3.8	0.2	1.4	2.0	3.0	3.5	3.9
Raft 20 person	0.4	1.5	2.2	3.3	4.0	4.4	0.4	1.5	2.2	3.4	4.0	4.5
Raft 25 person	0.4	1.6	2.4	3.6	4.3	4.8	0.3	1.6	2.4	3.6	4.4	4.9
Power Boat <5 (15 ft)	0.3	1.0	1.3	1.7	2.0	2.1	0.2	1.0	1.3	1.8	2.0	2.2
Power Boat 6 (20 ft)	0.4	1.7	2.5	3.7	4.5	5.1	0.3	1.7	2.5	3.8	4.6	5.1
Power Boat 10 (33 ft)	0.5	2.2	3.4	5.5	6.8	7.9	0.3	2.2	3.4	5.5	6.9	8.0
Power Boat 16 (53 ft)	0.5	2.6	4.5	8.2	11.0	13.2	0.4	2.6	4.5	8.3	11.0	13.3
Power Boat 24 (78 ft)	0.5	2.8	5.1	9.8	13.6	16.7	0.4	2.8	5.0	9.8	13.6	16.8
Sail Boat 5 (15 ft)	0.4	1.6	2.3	3.4	4.1	4.5	0.3	1.6	2.3	3.5	4.1	4.5
Sail Boat 8 (26 ft)	0.5	2.1	3.2	5.1	6.3	7.2	0.3	2.1	3.3	5.2	6.4	7.3
Sail Boat 12 (39 ft)	0.5	2.6	4.3	7.6	10.1	12.0	0.4	2.5	4.3	7.7	10.1	12.1
Sail Boat 15 (49 ft)	0.5	2.7	4.6	8.5	11.4	13.8	0.4	2.7	4.6	8.6	11.5	13.9
Sail Boat 21 (69 ft)	0.5	2.8	4.9	9.4	12.8	15.7	0.4	2.7	4.9	9.4	12.9	15.7
Sail Boat 25 (83 ft)	0.5	2.8	5.1	10.0	13.8	17.1	0.4	2.8	5.1	10.0	13.9	17.1
Ship 27-46 (90-150 ft)	0.5	2.9	5.4	11.1	16.0	20.1	0.4	2.9	5.4	11.1	16.0	20.1
Ship 46-91 (150-300 ft)	0.5	3.0	5.7	12.5	18.9	24.7	0.4	3.0	5.7	12.5	18.9	24.7
Ship > 91 (>300 ft)	0.6	3.0	5.8	13.2	20.7	27.9	0.5	3.0	5.8	13.2	20.6	27.9

Table D-5:6 (2) Uncorrected Sweep Widths for Fixed-Wing Aircraft (NM) at 1500 ft and 2000 ft

Note:

1. For search altitudes of 500 feet only, the sweep width values for a person in water may be multiplied by 4, if it is known that the person is wearing a flotation device.
2. A sailboat is only a sailboat if the sails are up. If the sails are down, the craft should be classed as a powerboat.

Weather Correction Factors for all Types of Search Facilities

Weather: Winds Km/h (kt) or seas m (ft)	Search Object	
	Person in water, raft or boat <10 m (33 ft)	Other search objects
Winds <28 Km/h (<15 kts) or seas 0-1 m (0-3 ft)	1.0	1.0
Winds 28-46 Km/h (15-25 kts) or seas 1-1.5 m (3-5 ft)	0.5	0.8
Winds >46 Km/h (>25 kts) or seas >1.5 m (>5 ft)	0.25	0.5

Table D-5:4 Weather Correction Factors for all Types of Search Facilities

Note: This table differs from IAMSAR for other search objects in winds greater than 15 kts. This is based on previous values used and observations of the reported effects of high winds on sweep width values in actual SAR incidents.

Uncorrected Sweep Widths for Helicopters (NM) – Maritime 500 ft and 1000 ft

Search Object [Metres (ft)]	Altitude 500 (ft)						Altitude 1000 (ft)					
	Visibility [Km]						Visibility [Km]					
	2	5	10	20	30	>40	2	5	10	20	30	>40
Person in Water	0.0	0.1	0.1	0.1	0.1	0.1	0.0	0.1	0.1	0.1	0.1	0.1
Raft 1 person	0.4	0.9	1.2	1.6	1.8	1.8	0.4	0.9	1.2	1.6	1.8	1.8
Raft 4 person	0.5	1.2	1.6	2.2	2.6	2.8	0.5	1.2	1.7	2.3	2.6	2.9
Raft 6 person	0.5	1.4	1.9	2.7	3.2	3.5	0.5	1.4	2.0	2.8	3.2	3.5
Raft 8 person	0.6	1.5	2.0	2.8	3.3	3.7	0.5	1.5	2.1	2.9	3.4	3.8
Raft 10 person	0.6	1.6	2.2	3.1	3.6	4.0	0.5	1.6	2.2	3.2	3.7	4.1
Raft 15 person	0.6	1.7	2.3	3.3	4.0	4.4	0.6	1.7	2.4	3.5	4.1	4.5
Raft 20 person	0.6	1.8	2.6	3.8	4.6	5.1	0.6	1.8	2.7	3.9	4.7	5.2
Raft 25 person	0.6	1.9	2.7	4.1	5.0	5.6	0.6	1.9	2.8	4.2	5.1	5.7
Power Boat <5 (15 ft)	0.5	1.2	1.5	1.9	2.2	2.3	0.5	1.2	1.6	2.1	2.3	2.5
Power Boat 6 (20 ft)	0.7	2.0	2.9	4.3	5.2	5.8	0.7	2.1	3.0	4.4	5.3	5.9
Power Boat 10 (33 ft)	0.8	2.5	3.9	6.2	7.8	9.0	0.7	2.6	3.9	6.3	7.9	9.1
Power Boat 16 (53 ft)	0.8	3.1	5.1	9.2	12.3	14.7	0.7	3.1	5.2	9.2	12.3	14.8
Power Boat 24 (78 ft)	0.8	3.3	5.7	10.8	15.0	18.4	0.8	3.3	5.7	10.9	15.0	18.5
Sail Boat 5 (15 ft)	0.7	1.9	2.7	3.9	4.7	5.2	0.6	1.9	2.8	4.0	4.8	5.4
Sail Boat 8 (26 ft)	0.8	2.4	3.7	5.7	7.1	8.2	0.7	2.5	3.7	5.8	7.3	8.3
Sail Boat 12 (39 ft)	0.8	3.0	4.9	8.3	11.3	13.5	0.7	3.0	4.9	8.6	11.4	13.5
Sail Boat 15 (49 ft)	0.8	3.1	5.2	9.5	12.7	15.3	0.7	3.1	5.3	9.5	12.8	15.4
Sail Boat 21 (69 ft)	0.8	3.2	5.5	10.4	14.1	17.3	0.8	3.2	5.6	10.4	14.2	17.3
Sail Boat 25 (83 ft)	0.8	3.3	5.7	11.0	15.2	18.7	0.8	3.3	5.7	11.0	15.3	18.8
Ship 27-46 (90-150 ft)	0.8	3.4	6.0	12.2	17.4	21.9	0.8	3.4	6.0	12.2	17.4	21.9
Ship 46-91 (150-300 ft)	0.8	3.4	6.3	13.6	20.4	26.6	0.8	3.4	6.3	13.6	20.4	26.6
Ship > 91 (>300 ft)	0.8	3.5	6.4	14.3	22.1	29.8	0.8	3.5	6.4	14.3	22.2	29.8

Table D-5:7 (1) Uncorrected Sweep Widths for Helicopters (NM) – Maritime 500 ft and 1000 ft

Notes:

1. For search altitudes of 500 feet only, the sweep width values for a person in water may be multiplied by four (4), if it is known that the person is wearing a flotation device.
2. A sailboat is only a sailboat if the sails are up. If the sails are down, the craft should be classed as a powerboat.

Weather correction factors for all types of search facilities

Weather: winds Km/h (kt) or seas m (ft)	Search Object	
	Person in water, raft or boat < 10 m (33 ft)	Other search objects
Winds <28 Km/h (<15 kt) or seas 0-1 m (0-3 ft)	1.0	1.0
Winds 28-46 Km/h (15-25 kt) or seas 1-1.5 m (3-5 ft)	0.5	0.8
Winds >46 Km/h (> 25 kt) or seas > 1.5 m (> 5 ft)	0.25	0.5

Table D-5:4 Weather Correction Factors for all Types of Search Facilities

Note: This table differs from IAMSAR for other search objects in winds greater than 15 kts. This is based on previous values used and observations of the reported effects of high winds on sweep width values in actual SAR incidents.

Uncorrected Sweep Widths for Helicopters (NM) - Maritime 1500 ft and 2000 ft

Search Object [Metres (ft)]	Altitude 1500 (ft)						Altitude 2000 (ft)					
	Visibility [Km]						Visibility [Km]					
	2	5	10	20	30	>40	2	5	10	20	30	>40
Person in Water	0.0	0.0	0.0	0.1	0.1	0.1	0.0	0.0	0.0	0.0	0.0	0.1
Raft 1 person	0.3	0.9	1.2	1.6	1.8	1.8	0.2	0.8	1.2	1.6	1.8	1.8
Raft 4 person	0.4	1.2	1.7	2.3	2.7	2.9	0.3	1.2	1.7	2.3	2.7	3.0
Raft 6 person	0.4	1.4	2.0	2.8	3.3	3.6	0.3	1.4	2.0	2.8	3.3	3.6
Raft 8 person	0.4	1.5	2.1	3.0	3.5	3.9	0.3	1.5	2.1	3.0	3.6	3.9
Raft 10 person	0.4	1.6	2.2	3.2	3.8	4.2	0.3	1.6	2.3	3.3	3.9	4.2
Raft 15 person	0.5	1.7	2.4	3.5	4.2	4.6	0.3	1.7	2.5	3.6	4.3	4.7
Raft 20 person	0.5	1.9	2.7	4.0	4.8	5.3	0.4	1.8	2.7	4.0	4.9	5.4
Raft 25 person	0.5	2.0	2.9	4.3	5.2	5.6	0.4	1.9	2.9	4.3	5.3	5.9
Power Boat <5 (15 ft)	0.4	1.3	1.7	2.2	2.5	2.6	0.3	1.3	1.7	2.3	2.6	2.7
Power Boat 6 (20 ft)	0.6	2.1	3.0	4.5	5.4	6.1	0.4	2.1	3.0	4.5	5.5	6.1
Power Boat 10 (33 ft)	0.6	2.6	4.0	6.3	7.9	9.2	0.5	2.6	4.0	6.4	8.0	9.3
Power Boat 16 (53 ft)	0.7	3.1	5.2	9.3	12.4	14.8	0.5	3.0	5.2	9.3	12.4	14.9
Power Boat 24 (78 ft)	0.7	3.2	5.7	10.9	15.1	18.5	0.5	3.2	5.7	10.9	15.1	18.5
Sail Boat 5 (15 ft)	0.6	2.0	2.8	4.1	4.9	5.5	0.4	1.9	2.8	4.2	5.0	5.6
Sail Boat 8 (26 ft)	0.6	2.5	3.8	5.9	7.4	8.4	0.5	2.5	3.8	6.0	7.5	8.6
Sail Boat 12 (39 ft)	0.6	3.0	4.9	8.7	11.4	13.6	0.5	3.0	4.9	8.7	11.4	13.6
Sail Boat 15 (49 ft)	0.7	3.1	5.3	9.6	12.8	15.5	0.5	3.1	5.3	9.6	12.9	15.5
Sail Boat 21 (69 ft)	0.7	3.2	5.6	10.4	14.3	17.4	0.5	3.2	5.6	10.5	14.3	17.4
Sail Boat 25 (83 ft)	0.7	3.3	5.7	11.1	15.3	18.8	0.5	3.2	5.7	11.1	15.4	18.9
Ship 27-46 (90-150 ft)	0.7	3.3	6.0	12.2	17.5	22.0	0.5	3.3	6.0	12.2	17.5	22.0
Ship 46-91 (150-300 ft)	0.7	3.4	6.3	13.6	20.4	26.6	0.5	3.4	6.3	13.6	20.4	26.6
Ship > 91 (>300 ft)	0.7	3.4	6.4	14.3	22.2	29.8	0.6	3.4	6.4	14.3	22.2	29.8

Table D-5:7 (2) Uncorrected Sweep Widths for Helicopters (NM) - Maritime 1500 ft and 2000 ft

Notes:

1. For search altitudes of 500 feet only, the sweep width values for a person in water may be multiplied by four (4), if it is known that the person is wearing a flotation device.
2. A sailboat is only a sailboat if the sails are up. If the sails are down, the craft should be classed as a powerboat.

Weather correction factors for all types of search facilities

Weather: winds Km/h (kt) or seas m (ft)	Search Object	
	Person in water, raft or boat < 10 m (33 ft)	Other search objects
Winds <28 Km/h (<15 kt) or seas 0-1 m (0-3 ft)	1.0	1.0
Winds 28-46 Km/h (15-25 kt) or seas 1-1.5 m (3-5 ft)	0.5	0.8
Winds >46 Km/h (> 25 kt) or seas > 1.5 m (> 5 ft)	0.25	0.5

Table D-5:4 Weather Correction Factors for all Types of Search Facilities

Note: This table differs from IAMSAR for other search objects in winds greater than 15 kts. This is based on previous values used and observations of the reported effects of high winds on sweep width values in actual SAR incidents.

Fixed-wing Aircraft Search Facilities

Search Object	Fixed Wing Speed (kt)			Helicopter speed (kt)			
	< or = 150	180	210	< or = 60	90	120	140
Person in Water	1.2	1.0	0.9	1.5	1.0	0.8	0.7
Raft 1-4 Person	1.1	1.0	0.9	1.3	1.0	0.9	0.8
Raft 6-25 Person	1.1	1.0	0.9	1.2	1.0	0.9	0.8
Power Boat - < 8 m (< 25 ft)	1.1	1.0	0.9	1.2	1.0	0.9	0.8
Power Boat – 10 m (33 ft)	1.1	1.0	0.9	1.1	1.0	0.9	0.9
Power Boat – 16 m (53 ft)	1.1	1.0	1.0	1.1	1.0	0.9	0.9
Power Boat – 24 m (78 ft)	1.1	1.0	1.0	1.1	1.0	1.0	0.9
Sail Boat - < 8 m (< 25 ft)	1.1	1.0	0.9	1.2	1.0	0.9	0.9
Sail Boat – 12 m (39 ft)	1.1	1.0	1.0	1.1	1.0	0.9	0.9
Sail Boat – 25 m (83 ft)	1.1	1.0	1.0	1.1	1.0	1.0	0.9
Ship – > 27 m (> 90 ft)	1.0	1.0	1.0	1.1	1.0	1.0	0.9

Table D-5:8 Speed (velocity) Correction Factors for Helicopter and Fixed-wing Aircraft Search Facilities

Sweep Width Tables for Visual Search Over Land

Search object	Height (ft)	Visibility [Km]				
		5 Km	10 Km	20 Km	30 Km	40 Km
Person	500	0.4	0.4	0.5	0.5	0.5
	1000	0.4	0.4	0.5	0.5	0.5
	1500	-	-	-	-	-
	2000	-	-	-	-	-
Vehicle	500	0.9	1.3	1.3	1.3	1.3
	1000	1.0	1.4	1.4	1.5	1.5
	1500	1.0	1.4	1.7	1.7	1.7
	2000	1.0	1.5	2.0	2.0	2.0
Aircraft less than 5700 kg	500	1.0	1.4	1.4	1.4	1.4
	1000	1.0	1.5	1.5	1.6	1.6
	1500	1.0	1.5	1.8	1.8	1.8
	2000	1.0	1.6	2.0	2.0	2.0
Aircraft over 5700 kg	500	1.2	2.0	2.2	2.2	2.2
	1000	1.8	2.7	3.0	3.0	3.0
	1500	2.0	2.8	3.2	3.2	3.2
	2000	2.2	2.9	3.5	3.5	3.5

Table D-5:9 Uncorrected Sweep Widths for Visual Land Search (NM)

Correction Factors – Vegetation and High Terrain

Search object	Less than 15% vegetation, open areas or scattered timber	15-60% vegetation or hilly; medium forest or scrub	60-85% vegetation or mountainous; dense forest or scrub	Over 85% vegetation; rain forest
Person	0.8	0.5	0.3	0.1
Vehicle	1.0	0.7	0.4	0.1
Aircraft < 5700 kg	1.0	0.7	0.4	0.1
Aircraft > 5700 kg	1.0	0.8	0.4	0.1

Table D-5:10 Correction Factors – Vegetation and High Terrain

Appendix D-6 Probable Errors of Position

Probable Navigation Error of the Target (x)

1. Initial Position Error (X) of the target and Search Craft Position Error (Y) are the estimated errors of position based on navigational accuracy of the target and of the search assets.

If the information on the means of navigation to be used by the target or by a search facility is available, the navigational fix errors listed in Table D-6:1 may be used for positions reported as navigational fixes.

Means of Navigation	Fix error (NM)
GPS	0.1 NM
RADAR	1 NM
Visual fix (3 lines) *	1 NM
Celestial fix (3 lines) *	2 NM
Marine Radio Beacon	4 NM (3 beacon fix)
INS	0.5 NM per flight hour without update
VOR	+ or - 3 DEG arc and 3% of distance or 0.5 NM radius, whichever is greater
TACAN	+ or - 3 DEG arc and 3% of distance or 0.5 NM radius, whichever is greater

Table D-6:1 Navigational Fixed Errors

* Should be evaluated upward according to circumstances

Note: Variation from IAMSAR for Tables D-6:2 & D-6:3, the National SAR Manual uses the values previously used by JRCC Australia because experience has shown it is more practicable to base fix errors on the navigation equipment carried in a craft.

2. The above values for Fix errors in Table D-6:1 are appropriate for the actual position of a target and/or search assets. An SMC should be aware that if the values in Table D-6:1, particularly that for GPS, are used to calculate a Total Probable Error of Position (E) for a Stage 3 search, particularly for a search over land or any search for an aircraft, the search area produced, because of its dimensions, may not be practical to use.
3. When designing a search area an SMC can always use his discretion, however, to obtain a practical search area it is recommended that the fix errors in Tables D-6:2 & D-6:3 be utilised.
4. When the means of navigation used by the target or by a search asset is unknown or the SMC wishes to produce a practical search area for a Stage 3 search, the following Fix errors may be applied:

Type of Craft	Fix Error
Ships, military submarines	5 NM radius
Aircraft navigated by a self-contained navigation system	5 NM radius
Aircraft (other)	10 NM radius
Small craft, Submersibles	15 NM radius

Table D-6:2 Type of Craft

5. When the initially reported position of the target is based on dead reckoning (DR) or the search asset must use DR navigation, an additional error is assumed for the distance travelled since the last fix. The position error is the sum of the fix error plus the DR error (DRe) as shown in Table D-6:3.

Type of craft	DR error (DRe)
Ship, Submarine (Military)	The error of the last positive fix plus 5% of the distance from that fix
Aircraft	The error of the last positive fix plus 10% of the distance from that fix
Small craft, Submersibles	The error of the last positive fix plus 15% of the distance from that fix

Table D-6:3 Dead Reckoning (DR) Errors

6. The figures and factors shown in Tables D-6:1 to D-6:3 are minimum values and may be increased at the SMC's discretion should information be received indicating that the navigational accuracy of either the distressed or the search craft differs significantly from the accepted standard.
7. As an example, the 'x' factor for a missing aircraft with two or more engines not using a self-contained navigation system which reported at position 'A', but failed to report at position 'B' 200 NM distant, would be:
for 'A' 10 NM, and,
for 'B', $10 + 20 = 30$ NM.
8. Should a pressurised aircraft suffer a major loss of cabin pressure when flying above the oxygen height the pilot will put the aircraft into a steep diving turn to bring the aircraft down to 10,000 ft as quickly as possible. The possibility of this manoeuvre being made and the consequent diversion from track should be considered when constructing a probability area.

Probable Navigation error of the Search Craft (y)

9. All search craft are expected to obtain frequent, and near continuous navigational fixes while conducting their search; therefore, only fix error is considered for search craft. Should it be necessary to navigate a search craft by DR in a search area, the RCC should be notified so that both fix, and DR error can be taken into account in determining the 'y' factor.

The figures selected in respect of a search craft will depend on the method of navigation to be used by the search craft. The figures in Tables D-6:1 to D-6:3 shall be taken as minimum values and may be increased at the discretion of the SMC.

Appendix D-7 Maritime and Aviation Worksheets

Overview

The following pages provide worksheets to assist in calculating various SAR related problems:

- Worksheet 1: Maritime Planning
- Worksheet 2: Maritime Area (searching by aircraft)
- Worksheet 3: Land Search Calculations
- Worksheet 4: Search Radius
- Worksheet 5: Sector Search
- Worksheet 6: Aircraft Allocation
- Worksheet 7: Maritime Allocation
- Worksheet 8: Maritime Area (searching by vessel)

Worksheet 1 – Maritime Planning

Worksheet 1: Maritime Planning				
INCIDENT				
Search target (description):				
LKP (Lat / Long):				
@Time (UTC):				
Hours of drift (a):				
SEA CURRENT				
Sea / tidal current / knots:	°(T)	knots		
Sea Current vector / distance:	°(T)	knots	x	(a) hrs = NM
SURFACE WIND and WIND CURRENT				
Surface winds / knots	°(T)	knots	Wind Current Divergence = Reciprocal Surface Wind - 30° for LKP greater than 10° South Latitude	
Reciprocal of Surface Winds / Knots (b)	°(T)	knots	-30°T =	°(T) knots
Wind current vector: (use reciprocal bearing and divergence (Figure D-5:25):	(a)	hours x	knots	°(T) NM
TARGET LEEWAY				
Leeway Angles (divergence) (Table D-5:1 or D-5:2):	Reciprocal Surface Wind (b)	°(T)	±	°(T)
Leeway vector: (LW)	L W (L) -	°(T)		L W (R) + °(T)
Leeway speed: (knots) = (Multiplier x Wind Speed) ± Modifier (Table D-5:1 or D-5:2)	[Multiplier x	Wind Speed =] ± Modifier =
Leeway distance:	Leeway speed	x (a)	hrs =	NM
DRIFT ERROR				
Distance (L):	NM		Distance (R):	NM
de(L):(12.5 to 33% of Distance L)	NM		de (R): (12.5 to 33% of Distance R)	NM
Distance Left / Right =	NM	$De = \frac{[de (L) + de (R) + Distance L/R]}{2}$		De =
FIX ERRORS				
Target errors (x): (Table D-6:1, D-6:2 & D-6:3)	NM			
Search craft error (y): (Table D-6:1, D-6:2 & D-6:3)	NM			
TOTAL ERROR (E)				
Total probable error (E): $E = \sqrt{De^2+x^2+y^2}$	E =			
SEARCH AREA				
Safety Factor (circle) (fs)	1.1	1.6	2.0	2.3 2.5
Search radius (E x fs)	NM			
Rounded up to whole figure:	NM			
Search area:	NM ²			

Worksheet 2 – Maritime Search by Aircraft

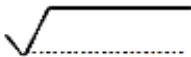
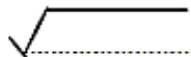
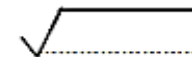

Worksheet 2: Maritime Search by Aircraft								
INCIDENT REFERENCE:	COMPLIED BY:							
	DATE:							
Search Platform..... Search Platform TAS..... Search Object.....								
MET Visibility.....Km Wind...../..... Fatigue Factor: YES or NO								
Search Height (AGL)	500 ft	1000 ft	1500 ft	2000 ft				
Uncorrected Sweep Width (WU) -Tables D-5:3, D-5:5, D-5:6(1), D-5:6(2), D-5:7(1), D-5:7(2)	NM	NM	NM	NM				
Maritime: Weather Correction Factor (Fw) -Table D-5:4								
Speed Correction Factor (Fs) a) Aircraft searching over water use Fs from Table D-5:8 b) Searches by vessels enter 1.0								
Fatigue Correction Factor (Ff) if crew will be suffering significant fatigue enter 0.9 otherwise enter 1.0								
Sweep Width Factor W = (Wu x Fw x Fs x Ff)								
Practical Track Spacing S (NM)								
Coverage Factor C = W/S								
Probability of Detection (POD)								
Search Area A (SQ NM)								
Search Hours (T) Required at 120 KTSS (V) T = A/VS								
Total Search Hours Available at 120 KTC (.....) - (from Worksheet 6)								
A. Whole Area Calculated at a Search Height ofFT (A = TVS C = W/S S = W/C)								
A	SQ. NM	S	NM	C	P	%	FOR	SEARCH
B. Modified Area at Calculated Track Spacing in Available Hours								
A	SQ. NM	S	NM	C	P	%	FOR	SEARCH
C. Whole Area at Modified Track Spacing in Available Hours								
A	SQ. NM	S	NM	C	P	%	FOR	SEARCH
D. Compromise Area and Modified Practical Track Spacing in Available Hours								
(i) A	SQ. NM	S	NM	C	P	%	FOR	SEARCH
(ii) A	SQ. NM	S	NM	C	P	%	FOR	SEARCH
(iii) A	SQ. NM	S	NM	C	P	%	FOR	SEARCH
(iv) A	SQ. NM	S	NM	C	P	%	FOR	SEARCH
Mark selected variables with *								

Appendices

Worksheet 3 – Land Search by Aircraft

Worksheet 3: Land Search by Aircraft								
INCIDENT REFERENCE:	COMPLIED BY:							
	DATE:							
Search Object..... Vegetation: Less than 15% 15-60% 60-85% +85%								
MET Visibility.....Km Fatigue Factor: YES or NO								
Search Height (AGL)	500 ft	1000 ft	1500 ft	2000 ft				
Uncorrected Sweep Width (WU) - Table D-5:9	NM	NM	NM	NM				
Searches over land: use Terrain/Vegetation Correction Factor (Fv) - Table D-5:10								
Fatigue Correction Factor (Ff) if crew will be suffering significant fatigue enter 0.9 otherwise enter 1.0								
Sweep Width Factor W = (Wu x Fv x Ff)								
Practical Track Spacing S (NM)								
Coverage Factor C = W/S								
Probability of Detection (POD)								
Search Area A (SQ NM)								
Search Hours (T) Required at 120 KTSS (V) T = A/VS								
Total Search Hours Available at 120 KTC (.....) - (from Worksheet 6)								
E. Whole Area Calculated at a Search Height ofFT (A = TVS C = W/S S = W/C)								
A	SQ. NM	S	NM	C	P	%	FOR	SEARCH
F. Modified Area at Calculated Track Spacing in Available Hours								
A	SQ. NM	S	NM	C	P	%	FOR	SEARCH
G. Whole Area at Modified Track Spacing in Available Hours								
A	SQ. NM	S	NM	C	P	%	FOR	SEARCH
H. Compromise Area and Modified Practical Track Spacing in Available Hours								
(i) A	SQ. NM	S	NM	C	P	%	FOR	SEARCH
(ii) A	SQ. NM	S	NM	C	P	%	FOR	SEARCH
(iii) A	SQ. NM	S	NM	C	P	%	FOR	SEARCH
(iv) A	SQ. NM	S	NM	C	P	%	FOR	SEARCH
Mark selected variables with *								

Worksheet 4 – Search Radius

Incident Reference	Search and Rescue				Compiled By
	Worksheet No. 4 Search Radius				Date
Reported Distress Position S E Time UTC	<div style="border: 1px solid black; padding: 2px; display: inline-block;">or</div>	1. Last Positive Fix 2. Last Reported Posn 3. Missed position 4. Next Posn or Dest	Search No. Radius Computed For Search Commencing UTC Previous Search No. Radius Computed For Search Commenced UTC	Distress Craft Callsign/Identity	
	Position	A	B	C	D
Track distance since last Positive Fix	(Tr)
Distress Craft Position Error (Fix+10%Tr)	(x)
Search Craft Navigation Error	(y)
Probable Error of Position	(e)				
$e = \sqrt{x^2 + y^2}$	
Safety Factor for this search (1.1; 1.6; 2.0; 2.3; 2.5)	(fs)
Search Radius (R) = (e) x (fs)	(R)
Rounded up Radius	

Appendices

Worksheet 5 – Sector Search

INCIDENT REFERENCE		SEARCH AND RESCUE WORKSHEET NO. 5 SECTOR SEARCH				COMPILED BY _____ DATE: _____		
SECTOR SEARCH CALCULATIONS: SPLASH POINT or DATUM _____ S / _____ E								
		RADIUS _____ NM		C = W/MTS		TRACK MILES AVAILABLE FROM WORKSHEET No 6 _____ NM		
SEARCH HEIGHT (ft)	W	MTS	C	TRACK DISTANCE (D)	ANGULAR DISPLACEMENT (AD)	INITIAL TRACK (IT)	SUBSEQUENT TRACK ADJUSTMENT +/- (90 + AD/2)	POD
500								
1000								
1500								
2000								
		RADIUS _____ NM		C = W/MTS		TRACK MILES AVAILABLE FROM WORKSHEET No 6 _____ NM		
SEARCH HEIGHT (ft)	W	MTS	C	TRACK DISTANCE (D)	ANGULAR DISPLACEMENT (AD)	INITIAL TRACK (IT)	SUBSEQUENT TRACK ADJUSTMENT +/- (90 + AD/2)	POD
500								
1000								
1500								
2000								
		RADIUS _____ NM		C = W/MTS		TRACK MILES AVAILABLE FROM WORKSHEET No 6 _____ NM		
SEARCH HEIGHT (ft)	W	MTS	C	TRACK DISTANCE (D)	ANGULAR DISPLACEMENT (AD)	INITIAL TRACK (IT)	SUBSEQUENT TRACK ADJUSTMENT +/- (90 + AD/2)	POD
500								
1000								
1500								
2000								

Worksheet 6 – Aircraft Allocation

INCIDENT REFERENCE		SEARCH AND RESCUE WORKSHEET NO.6 AIRCRAFT ALLOCATION					AREA to be ALLOCATED _____ NM ²		COMPILED BY _____ DATE _____			
Sunrise		UTC	Sunset		UTC	FSL	UTC – LSL		UTC = TSL		Hours	Mins
Remarks	ACFT Type	Time AVBL	DIST	TRANS TI's	ETA Area	Actual SCH HRS (ASH)	ETD Area	ASH less 15%	SCH TAS	AREA ALLOCATED		
	Callsign	TKOF Time	TRANS TAS	ON SCH ENDCE				S	HRS (T) at 120 kt (V)	A=TVS	Dim's Used	ALLOC Area (NM ²)
E/										Cal Dim's	No. of Legs	
E/												
E/												
E/												
E/												
E/												
E/												

Appendices

Worksheet 8 – Maritime Search by Vessel

INCIDENT REFERENCE	SEARCH AND RESCUE WORKSHEET NO. 8 MARITIME SEARCH BY VESSEL	COMPILED BY _____						
		DATE						
Search Platform		Search Object						
MET Visibility Km		Wind /..... kt	Fatigue Factor: Yes or No					
Search Height (AGL)	Eye height 8 ft	Eye height 14 ft	MERSHIP					
Uncorrected Sweep Width (Wu) -Tables D-5:3 & D-5:5	NM	NM	NM					
Maritime: Weather Correction Factor (Fw) – Table D-5:4								
Fatigue Correction Factor (Ff) if crew will be suffering significant fatigue enter 0.9 , otherwise enter 1.0								
Sweep Width Factor W = (Wu x Fw x Ff)								
Practical Track Spacing S (NM)								
Coverage Factor C = W/S								
Probability of Detection (POD)								
Search Area A (SQ NM)								
Search Hours (T) Required T = A/VS								
Total Search Hours Available (.....) - (from Worksheet No. 7)								
A. Whole Area Calculated at a Search Height of ft (A = TVS C = W/S S = W/C)								
A	SQ. NM	S	NM	C	P	%	FOR	SEARCH
B. Modified Area at Calculated Track Spacing in Available Hours								
A	SQ. NM	S	NM	C	P	%	FOR	SEARCH
C. Whole Area at Modified Track Spacing in Available Hours								
A	SQ. NM	S	NM	C	P	%	FOR	SEARCH
D. Compromise Area and Modified Practical Track Spacing in Available Hours								
(i) A	SQ. NM	S	NM	C	P	%	FOR	SEARCH
(ii) A	SQ. NM	S	NM	C	P	%	FOR	SEARCH
(iii) A	SQ. NM	S	NM	C	P	%	FOR	SEARCH
(iv) A	SQ. NM	S	NM	C	P	%	FOR	SEARCH
Mark selected variables with *								

Appendices

Appendix D-8 Aircraft Accident Site Precautions

Safety Precautions and Procedures at Aircraft Accidents

1. Always remember that ADF aircraft may be carrying ammunition, bombs, rockets, etc. Ejector seats are powered by explosives. Contact ADF authorities as soon as possible.
2. The following precautions should be observed at all aircraft accident sites:
 - a) Attendance at crash sites should be limited to essential personnel;
 - b) Personnel should wear Personnel Protective Equipment (PPE) - see paragraph 2;
 - c) All work at the crash site should be conducted upwind of the wreckage wherever possible;
 - d) The location of helicopter landing zones in close proximity to crash sites should be avoided to prevent the possible spread of contamination;
 - e) Eating, drinking, and smoking in or around the crash site should be prohibited;
 - f) Aircraft technical personnel familiar with the aircraft type should be utilised in the location, identification, and salvage of hazardous materials and remnants;
 - g) Environmental health personnel should also be notified when suspected dangerous substances are present at the accident site;
 - h) SAR personnel who were working at the accident site should shower as soon as possible after leaving the area;
 - i) If time permits, advice to civilians in fallout areas that are not otherwise threatened should be:
 - i) Remain indoors;
 - ii) Shut external doors and windows;
 - iii) Turn off forced air intakes; and
 - iv) Await further notification.
3. Cordon off the area.
4. Personnel working within 10 m of any ADF crash site should wear the following protective equipment:
 - a) Respiratory protection; wear National Institute of Occupational Safety and Health approved full-face or half-mask respirators with cartridges for organic vapours (for protection from jet fuel) and for dust, mist, and fumes (for airborne particulate fibres and other dust). All personnel must be fit, tested, and trained in the use of respirators. The use of full-face respirators will eliminate the need for goggles or safety glasses;
 - b) Eye protection such as goggles or safety glasses with side shields shall be worn when a half-face respirator is used; and
 - c) Skin protection:
 - i) Coverall - Tyvek, coated with 1.25 mm polyethylene with hood. The coveralls should have a zipper front, elastic sleeves, legs, and drawstring hood;
 - ii) Gloves - Puncture resistant leather gloves shall be worn. The environmental engineers will determine any additional requirements;
 - iii) Boots - Steel toed shoes or boots should be worn; and
 - iv) All equipment should be thoroughly washed before removal.

Appendix D-9 Civil Aircraft Search and Rescue Assets (SRAs)

AMSA Aircraft Tier SRA Capability Definitions

CAPABILITY	DESCRIPTION
TIER 1	Dedicated fixed wing aircraft and crews, capable of electronic and visual search, deployment of emergency supplies, command and control, and homing to distress beacons.
Rotary Wing Rescue (RWR)	Rescue capable and winch-equipped helicopters and crew for rescue, homing to distress beacons, visual search, and limited supply dropping.
Rotary Wing Search (RWS)	Helicopters and crew for homing to distress beacons and visual search.
Fixed Wing Search (FWS)	Fixed wing aircraft and crew for homing to distress beacons, visual search and communications relay.

Table D-9:1 AMSA Aircraft SRA Tier Definitions

Tier 1 SRAs

AMSA contracts four dedicated Bombardier Challenger 604 jet aircraft for SAR at bases in Perth, Cairns and Melbourne with the fourth aircraft an operational spare. These aircraft have been modified to have a large visual observation window on each side and are fitted with a range of communications (UHF, VHF, HF and satellite telephones) and sensor systems (search RADAR, high definition EO/IR turret, NVDs, DF, AIS, ADS-B, video anomaly detection). These Challenger 604's are able to drop a range of life-support equipment on land and sea, by day and night including life rafts, SAR datum marker buoys and de-watering pumps. Communications equipment (radios and satellite phones) can also be dropped which, using the multi-mode communications relay capability of the aircraft, enable communications to be established between the surface and JRCC Australia or another command/control or response facility.

The aircraft are available to other government agencies, such as the police, fire and emergency services, on a whole-of-government basis, for assistance with response to emergency operations.



Photo: AMSA Challenger 604

Opportunity Based SAR Services

In addition to the dedicated Challenger 604 services contracted to Cobham SAR Services Pty Ltd, AMSA has existing arrangements with a number of Federal, State and Territory governments and agencies and other fixed wing and helicopter operators to provide AMSA with SAR services on an opportunity basis, that is, they are not dedicated AMSA services. These fall into the three categories in Table D – 9.1 above.

The aircraft available to AMSA include a range of aircraft operated or used by Federal, State and Territory governments, such as Australian Border Force, State/Territory Ambulance and Police Services and Australian Defence Force aircraft. AMSA also has arrangements with commercial operators for the use of a large selection of aircraft located around Australia.

The tasks capable of being conducted by these aircraft will vary based on individual capability, but aircraft will be capable of providing one or possibly more of the following:

- Visual searches - (both fixed wing and rotary wing) conducted either over land or water. Visual searches will be conducted either over land or water. Visual searches will be conducted during daylight hours and will not usually be conducted at altitudes below 500ft for fixed wing, but often lower for rotary wing. Observers, trained in aerial visual searching techniques, may be nominated by AMSA for carriage on the aircraft during search operations.
- Rescue - generally effected by rescue winch either over land or water. Winching operations will typically be conducted only during day visual meteorological conditions (VMC) unless operators are equipped, trained and authorised to conduct winching operations at night.
- Electronic searches - will be conducted by aircraft with electronic sensors, including search RADAR, NVDs or EO/IR. These aircraft may be used over land or water. Electronic searching can be conducted by day and/or night in VMC and/or instrument meteorological conditions (IMC).
- Deployment of emergency supplies - by rescue helicopters. This will be conducted only during day VMC, unless the operator is approved to deploy supplies at night.
- Homing to distress beacons - (both fixed wing and rotary wing) is conducted by aircraft equipped with an electronic homer (direction finder), or using aural homing techniques, either over land or water. Homing to beacons can be conducted either by day or night in both VMC and IMC.
- Communications relay - is conducted by fixed wing aircraft when communications with other search assets are poor or where there is a need to relieve congestion on ATS frequencies. Aircraft are required to be able to maintain communication with SAR or other assets or a ground station.

Current Aircraft and Police Fixed-Wing Operators

Fixed Wing Search (FWS) aircraft operators provide air search capability (visual search and DF) supportive and supplementary to the Tier 1 Challenger fleet. Each operator is supplied with safety and role equipment. Training, including emergency procedures drills, is provided by AMSA. AMSA Fixed Wing Search operators are located at various locations as shown in Figure D-9:3. AMSA also provides police fixed-wing operators with safety and role equipment for selected aircraft.

Air Search Observer Programme

AMSA maintains a partnership with State/Territory Emergency Service organisations to provide the SAR system with a large and dispersed pool of trained and readily mobilised air search observers. State and Territory Emergency Service volunteers undertake several days of initial training and regular refresher training, addressing safety on and around aircraft, emergency procedures (including pool drills with life rafts and lifejackets) and air search operations.

Air Search Equipment

AMSA maintains stocks of air search equipment (aircraft safety and role equipment) at strategic sites which can be transported to locations where search operations are being conducted.

Locations of Tier 1, 2 Assets

The following charts show the distribution of assets as at August 2018.

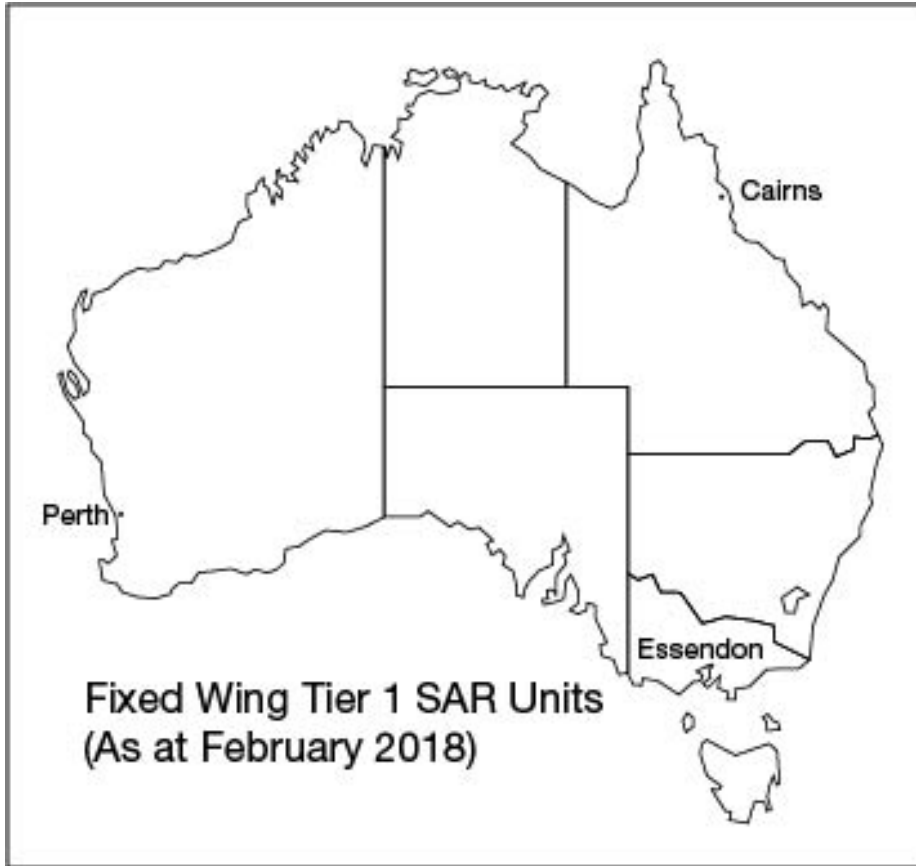


Figure D-9:1 Base Locations of AMSA Dedicated Tier 1 Aircraft SRAs

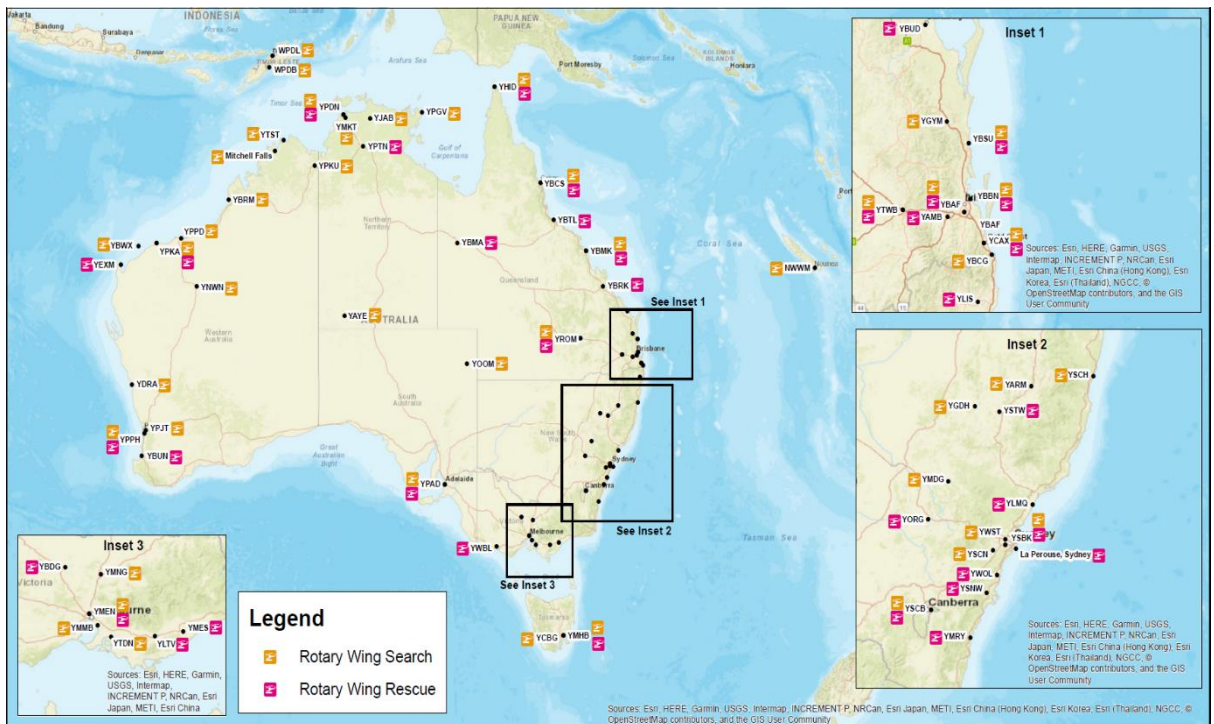


Figure D-9:2 Base Locations of Rotary Wing Search and Rotary Wing Rescue SRAs

Appendices

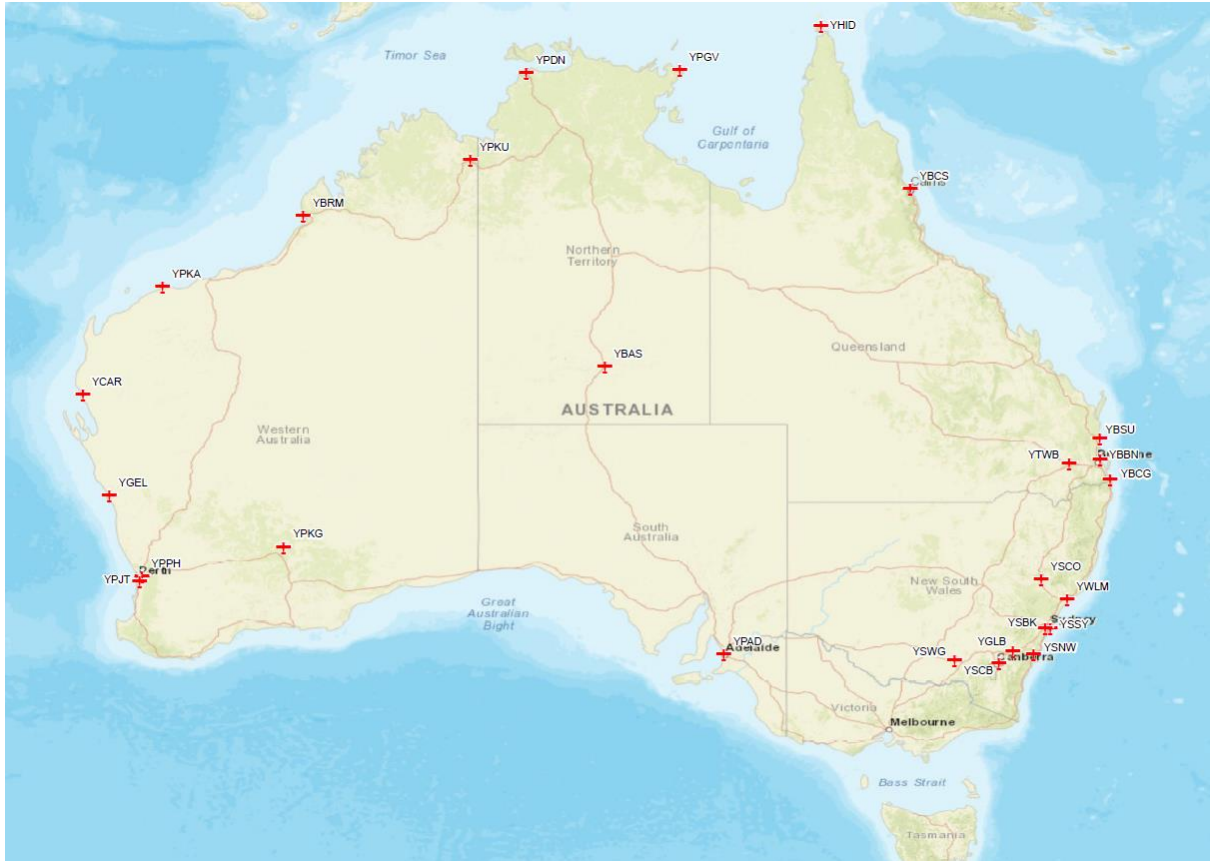


Figure D-9:3 Base Locations of Fixed-Wing Search and Police Fixed-Wing Aircraft SRAs

Appendix D-10 Coastal Datum Search and Rescue Planning

A Step-By-Step Guide for SAR Trained Personnel

Vessel Adrift

This is the simplest of all the datum SAR planning models. It is used when the last position of the vessel is known to within a high degree of accuracy.

Datum should be calculated for a time when the search assets are likely to be on scene. There is no point in calculating datum for a specific time, if there will be no resources in place to commence a search at this time.

Remember:

- All chart work is plotted in true on the chart.
- Wind is always referred to as blowing from (a Southerly wind is blowing South to North).
- Current is referred to as setting towards (a Westerly current is travelling East to West).

To commence the planning process, the planner needs some critical information, which is outlined below:

- a) **Target** type(s) must be determined.
- b) **Current**, the sea current direction and velocity must be determined as accurately as possible. With more accurate intelligence, as the operation progress, this part of the plan can be adjusted. All plots are directly down current, and the current rate multiplied by the number of hours adrift is applied.
- c) **Wind**, the wind direction and velocity must be determined as accurately as possible for the time that the incident occurred as well as what is happening for when datum is calculated. The target type is then used to calculate the leeway effect by referring to the Leeway Tables. All plots are directly downwind with the leeway rate determined (as described) multiplied by the number of hours adrift is applied.
- d) **Splash Point (SP)**, sometimes referred to as the Last Known Position (LKP) or Initial Position (IP). This is the last known position of the target when it became the target of the operation. In accordance with the definition of datum a time (clock time) and position (Latitude and Longitude) must be given.

For the purpose of this user guide the following example, with critical information, is used:

- a) **Target**
Light Displacement Cabin Cruiser (Without Drogue).
- b) **Current**
2 knots South Easterly (towards the S.E.)
- c) **Wind**
10 knots North Easterly (from the N. E.)
- d) **Splash Point**
27° 45.2' S 151° 27.1' E at 0800 hrs.
- e) **Calculate a Datum for 1000 hrs**
- f) **Current (WC)**
135° at 2 kts per hour. 2 kts x 2 hrs = 4 NM for the water current leg
- g) **Wind**
045° at 10 kts. Using the Leeway Formula:
 $[(0.07 \times 10) + 0.04] \times 2 \text{ hrs} = 1.48 \text{ NM}$

Step-By-Step Guide

1. Plot the Splash Point (SP) on the chart and notate as shown below in diagram 1. Splash point can also be known as Last Known Position (LKP) or Initial Planning Point (IPP).



Diagram 1

2. Plot the Total Water Current (WC) leg first, as shown in diagram 2 below. The reason for this is that if there is a possibility that the target is a person in the water, then the end of the WC leg becomes datum (D1). As shown in diagram 3.

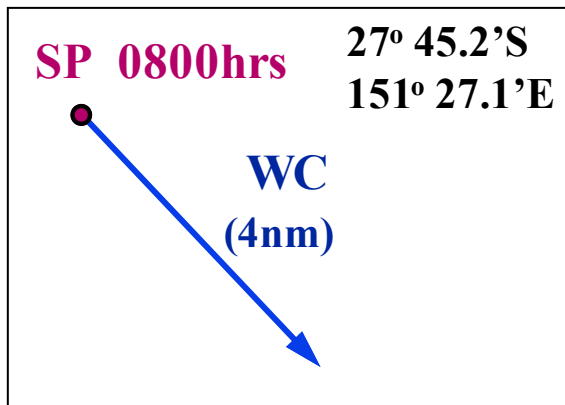


Diagram 2

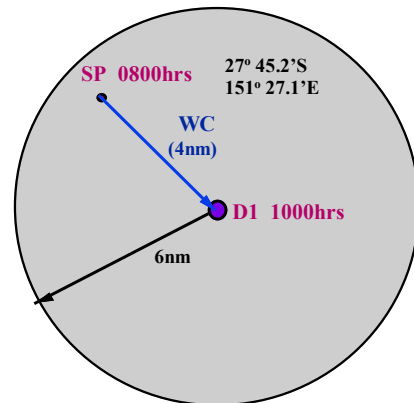


Diagram 3

Note: If there is doubt as to whether the target is a person in the water or a vessel, then D₁ is plotted at the end of the WC leg, D₂ would then be plotted at the intersection of the Leeway (LW) leg and Total Drift (TD) leg. See diagram 9. Vessel Adrift

3. Plot the Leeway leg (LW) second. This leg commences at the end of the WC leg. The length of the LW leg is calculated by using the Leeway tables. See Diagram 4 below.

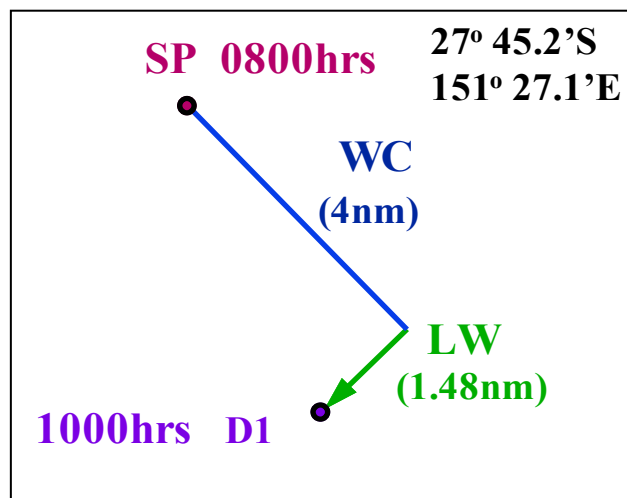


Diagram 4

The target type must be interpolated with the classes of vessels given. If it appears that the target could fall into more than one type, then calculate for both and plot both. The datum points arrived at will not differ by a great deal. Use both datum points to calculate the search area.

In this case using the formula for the target, which is a light displacement cabin cruiser without drogue:

$$0.07U + 0.04.$$

$$0.07 \times \text{the wind speed} + 0.04 \times \text{hours and decimals of an hour the vessel had been adrift.}$$

- Once both the WC and LW legs have been plotted, draw a line from SP to D1. The name of the line is called the 'Total Drift' or 'Resultant', indicate the direction of travel with an arrowhead in the centre of the line. Also note the direction of the TD line with a True bearing and measure the distance. See Diagram 5 below.

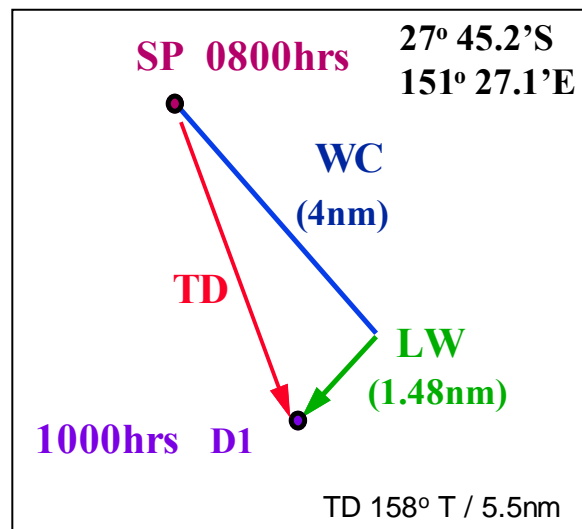


Diagram 5

- A 6 NM radius circle is drawn centred on datum (a 6 NM radius is used if the TD line is less than 8 NM in length), as indicated in Diagram 6 below.

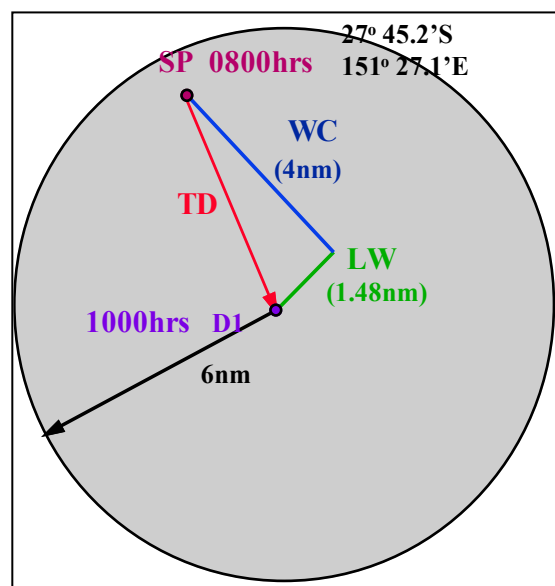


Diagram 6

- Once the circle is drawn, the area should be boxed, with the sides of the box touching the edges of the circle (tangential), and oriented in the direction of drift. This errs on the side of safety by building in a greater safety margin. It is also easier to plan search patterns and brief resources. See Diagram 7 below.

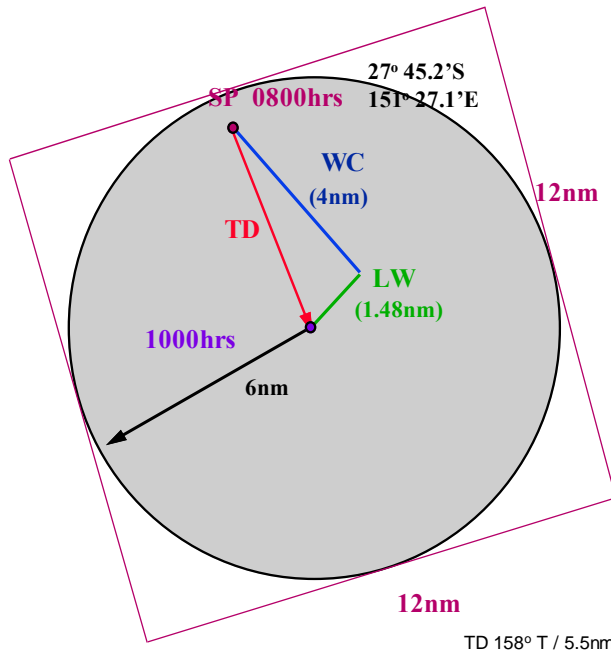
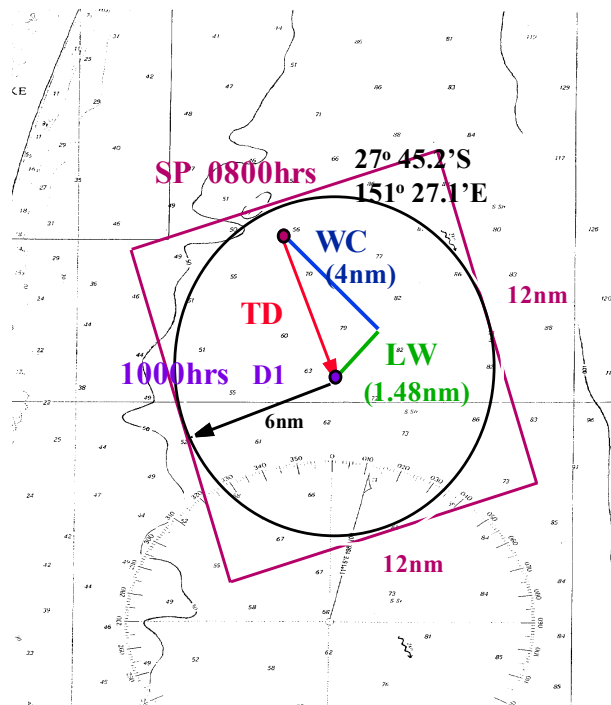


Diagram 7

- Diagram 8 below, shows what the datum SAR plan will look like on a chart.



TD 158° T / 5.5nm

Diagram 8

8. If there was uncertainty as to whether the target was a person in the water or a vessel adrift then Datum 1 (D1) should be located at the end of the water leg and Datum 2 (D2) should be located at the end of the leeway leg. Diagram 9 below shows the two circles one centred at (D1) and the other centred on (D2). The two circles would then be boxed (rectangle) together, with the box oriented in the direction of drift.

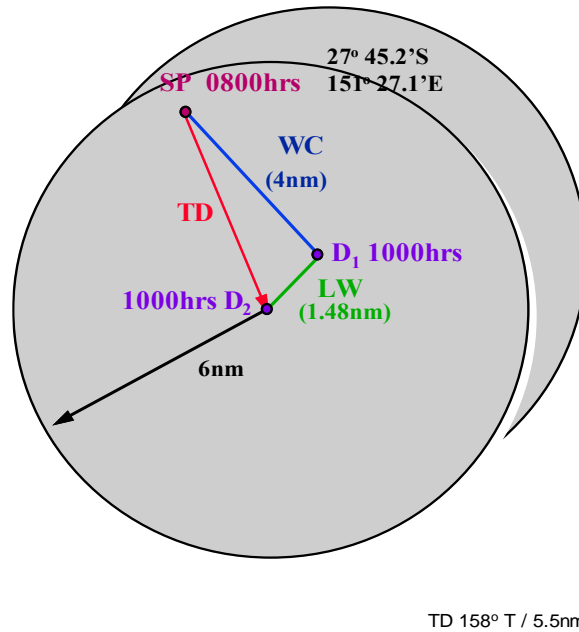


Diagram 9

9. As stated, if the total drift (TD) line is less than 8 nautical miles, then the radius of the circle is 6 NM, see Diagram 10 below.

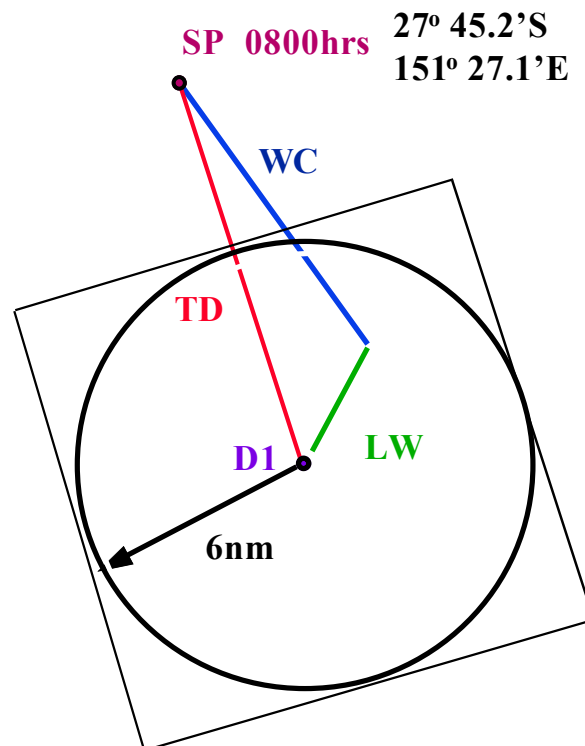


Diagram 10

10. If the total drift (TD) line is greater than 8 nautical miles, then the length of the total drift line is divided by 8. This is known as individual drift error.

The result is ADDED to the 6 NM radius circle usually used, creating a larger circle.

In Diagram 11 below, the TD line is 12 NM long. Therefore $12 \div 8 = 1.5$ NM. 1.5 NM is then added to 6 NM (the standard circle diameter) and the result is 7.5 NM for the radius of the circle.

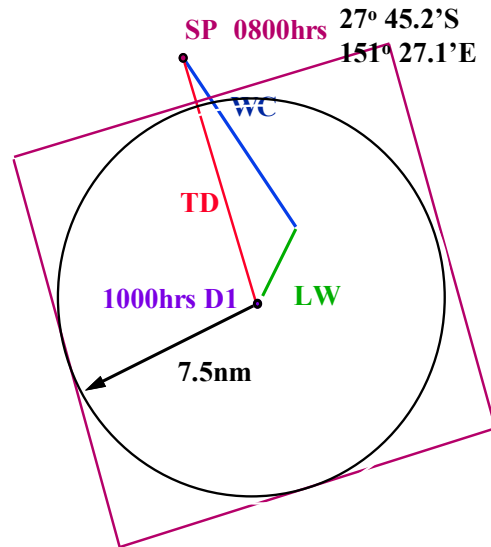


Diagram 11

Position Uncertainty

This model is a little bit more complex. It is the search procedure used when the intelligence has placed the Splash Point at more than one location, at the same point in time. It is important that Splash Points are calculated for the same specified time, it is just the positions that are different.

Datum should be calculated for a time when the search assets are likely to be on scene. There is no point in calculating datum for a specific time, if there will be no resources in place to commence a search at this time.

For the purpose of this user guide the following example, with critical information, is used:

- a) **Target**
Light Displacement Cabin Cruiser (Without Drogue).
- b) **Current**
1.5 knots 010°T
- c) **Wind**
10 knots Westerly (from the West) 270°T
- d) **Splash Point**
Two **positions** for the same specified time at 1000 hrs
- e) **Calculate a Datum for 1330 hrs**
- f) **Current (WC)**
030°T at 1.5 kts per hour. $1.5 \text{ kts} \times 3.5 \text{ hrs} = 5.25 \text{ NM}$ for the water current leg
- g) **Wind (LW)**
270°T at 10 kts. Using the Formula: $[(0.07 \times 10) + 0.04] \times 3.5 \text{ hrs} = 2.59 \text{ NM}$

Step-By-Step Guide

1. Plot the splash points (SP) on the chart and notate as shown below in diagram 1. Splash point can also be known as Last Known Position (LKP) or Initial Position (IP). Two positions geographically separated at the same time. This position can be caused by conflicting intelligence, confusion over a headland, island or bay.

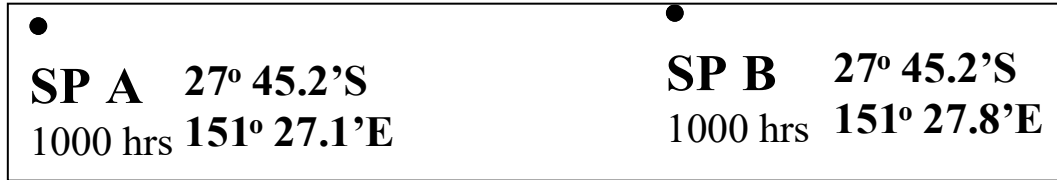


Diagram 12

2. Plot the Water Current (WC) leg first as per convention (see Diagram 13).

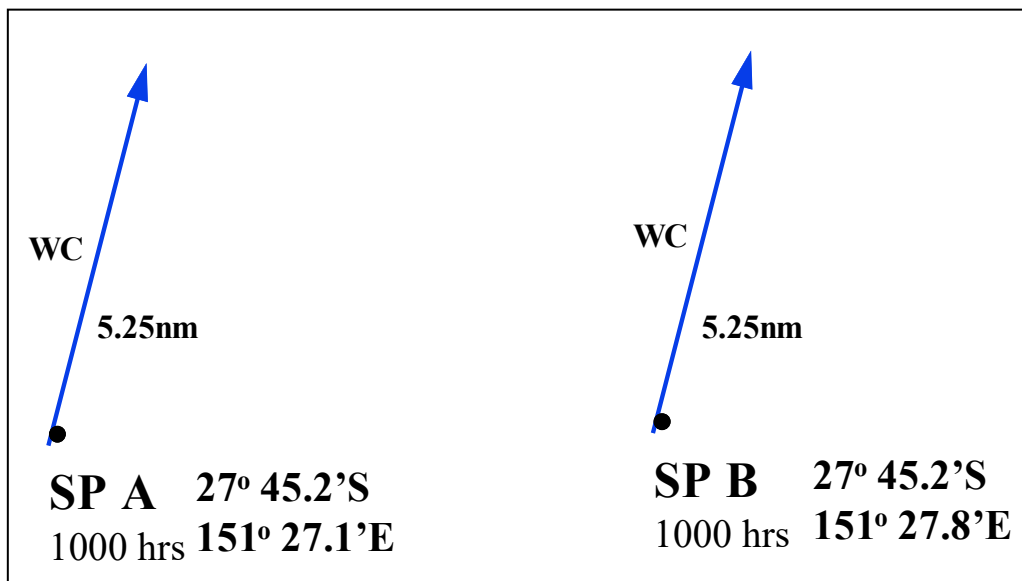


Diagram 13

Note: If there is doubt as to whether the target is a person in the water or a vessel, then two separate plots will be done, one for the person and one for the vessel, with both plotted together resulting in a larger search area.

3. Plot the Leeway leg (LW) second. This leg commences at the end of the WC leg. The length of the LW leg is calculated by using the Leeway Tables.

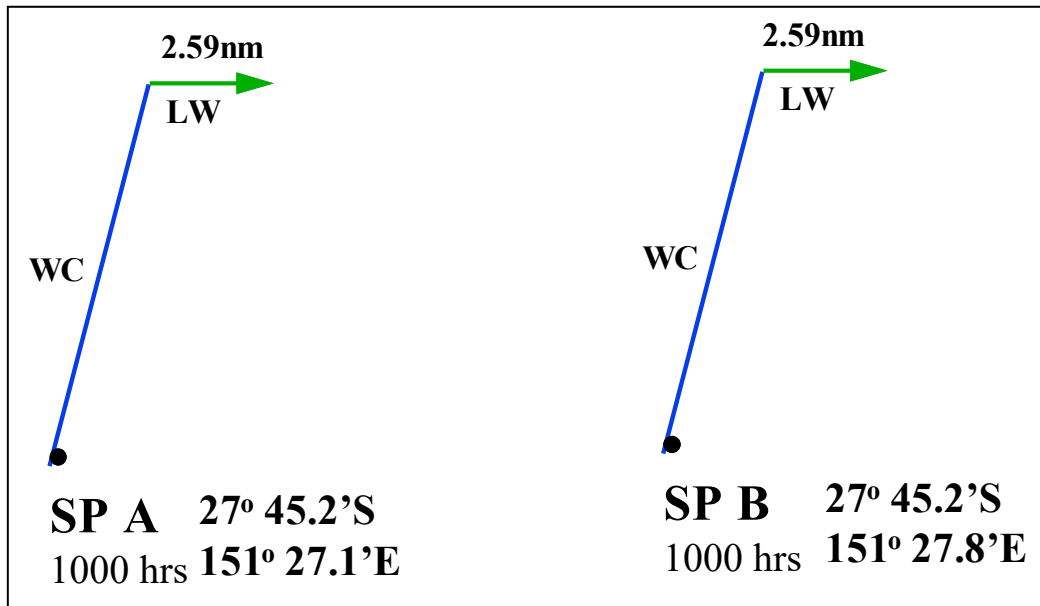


Diagram 14

- Once both the WC and LW legs have been plotted, draw a line from SP to D1. The name of the line is called the 'Total Drift' or 'Resultant', indicate the direction of travel with an arrowhead in the centre of the line. Also note the direction of the TD line with a True bearing and measure the distance (see Diagram 15 below).

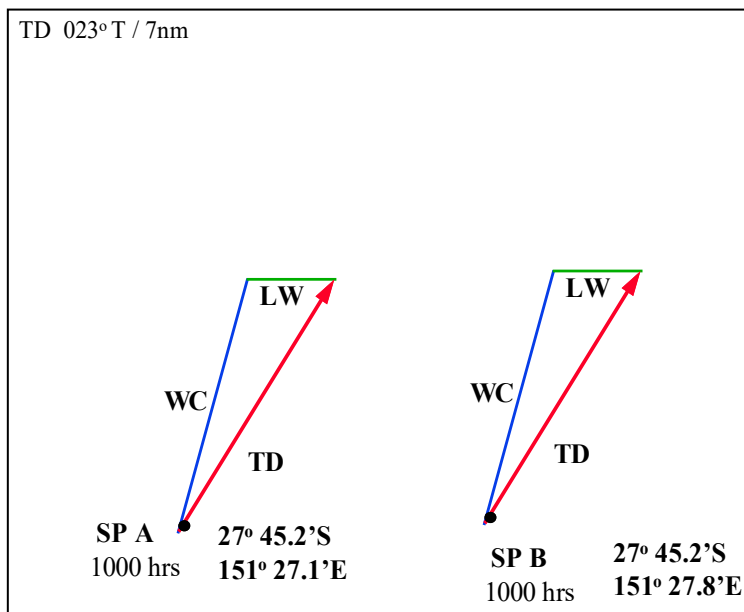


Diagram 15

- A 6 NM radius circle is drawn centred on datum (a 6 NM radius circle is used if the TD line is **less than** 8 NM in length, if greater than 8 NM apply the error mentioned in the Vessel Adrift example). As indicated in Diagram 16 below. A circle is drawn on both datums.

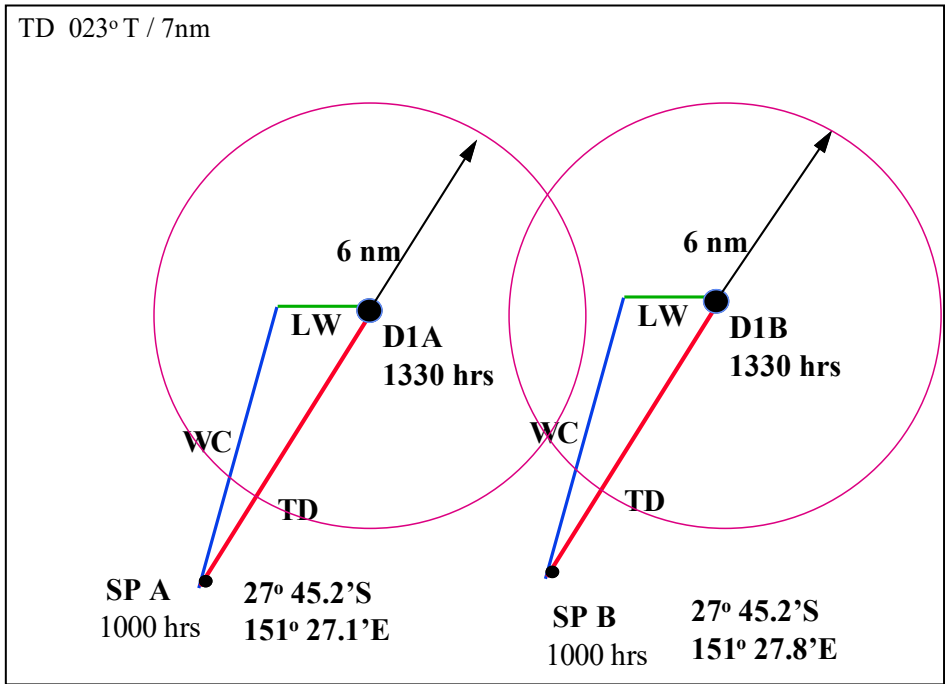


Diagram 16

- Once the circles are drawn, the area should be boxed, with the sides of the box touching the edges of the circles (tangential), and oriented in the direction of drift. This errs on the side of safety by building in a greater safety margin. It is also easier to plan search patterns and brief resources. See Diagram 17 below.

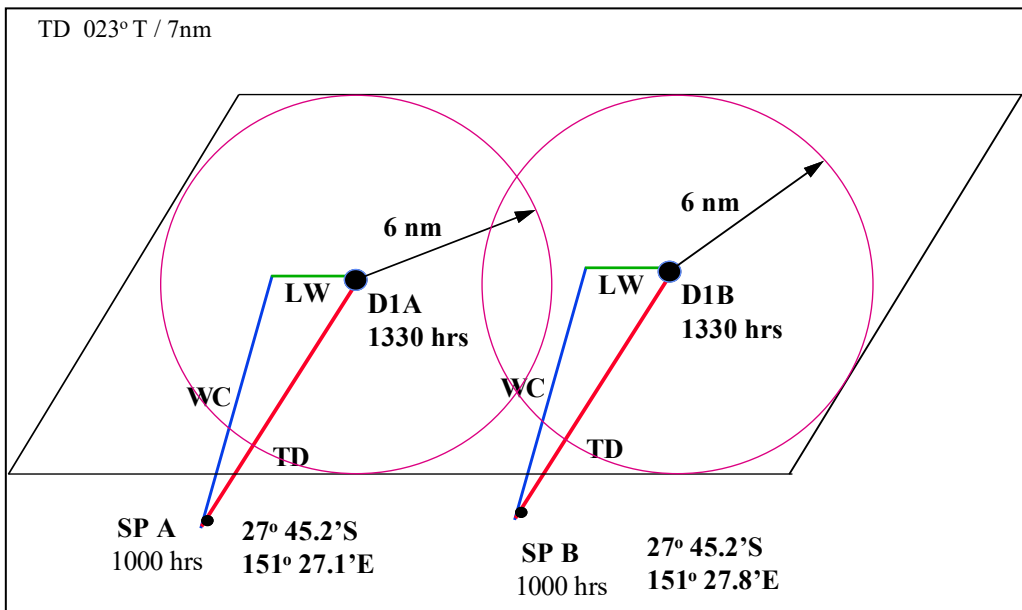


Diagram 17

- If the circles are separated by extreme distance, greater than 12 NM apart, then each area should be treated separately. In the prioritisation of search areas, the area between the two circles would be considered high in priority. If practicable, and a suitable number of resources are available, the area between the circles should be incorporated into the initial search area. See Diagram 18 below.

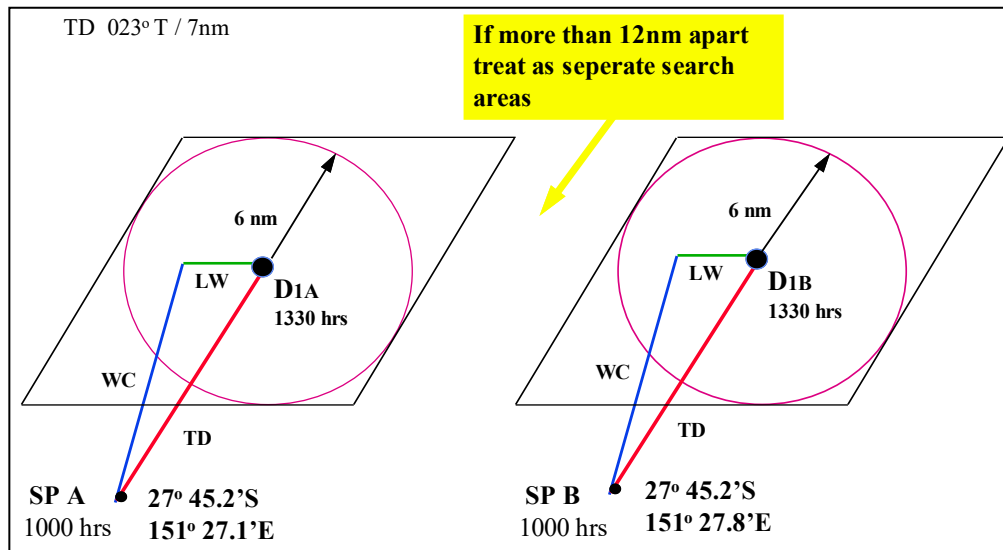


Diagram 18

Time Uncertainty

This model again is a little bit more complex. It is the search procedure used when the intelligence has placed the Splash Point at the one location, but at different points in time. For example, the target was known to be at the splash point, however there is conflicting evidence as to the time.

It is important that Splash Point is calculated for the both the minimum and maximum amount of time that the target could be missing, ascertained through the gathering of intelligence.

For the purpose of this user guide the following example, with critical information, is used:

a) **Target**

Light Displacement Cabin Cruiser (Without Drogue).

b) **Current**

1.5 knots 100°T

c) **Wind**

10 knots 018°T

d) **Splash Point**

27° 45.2' S 151° 27.1' E. The earliest the target may have got into trouble is 1000 hrs and the latest time the target may have got into trouble is 1200 hrs.

e) **Calculate a Datum for 1400 hrs**

f) **Current (WC)**

100°T at 1.5 kts per hour.

Position A - 1.5 kts x 2 hrs = 3 NM for the TWC (1200 hrs to 1400 hrs = 2 hrs)

Position B - 1.5 kts x 4 hrs = 6 NM for the TWC (1000 hrs to 1400 hrs = 6 hrs)

g) **Wind (LW)**

018°T at 10 kts. Using the Formula: $[(0.07 \times 10) + 0.04] = 0.74$ NM per hr

Position A - 0.74 NM x 2 hrs (time adrift) = 1.48 NM for the Leeway leg

Position B - 0.74 NM x 4 hrs (time adrift) = 2.96 NM for the Leeway leg

Step-By-Step Guide

1. Plot the Splash Point (SP) on the chart and notate as shown below in Diagram 19. Splash point can also be known as Last Known Position (LKP) or Initial Position (IP).

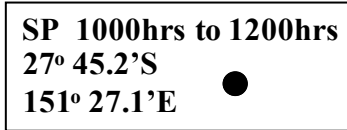


Diagram 19

2. Plot the Water Current (WC) leg first. The reason for this is that if there is a possibility that the target is a person in the water, then the end of the WC leg becomes datum (D1). As shown in Diagram 20 below.

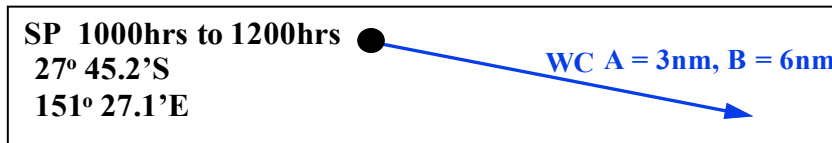


Diagram 20

3. Plot the Leeway leg (LW) second. In this case there are two leeway legs. The first of the leeway legs calculated is the amount of leeway effect on the vessel between 1000 hrs and 1400 hrs (this is the longest period of time in the calculation) and commences at the end of the WC leg.

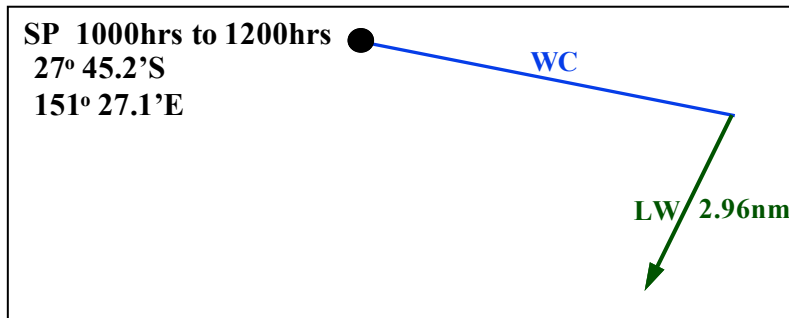


Diagram 21

4. Plot the second Leeway leg (LW). In this case the second leeway leg calculated is the amount of leeway effect on the vessel between 1200 hrs and 1400 hrs (this is the shortest period of time in the calculation). The leg commences at the corresponding point along the WC leg (which in this scenario is at the 2nd hour of water current effect along the WC line).

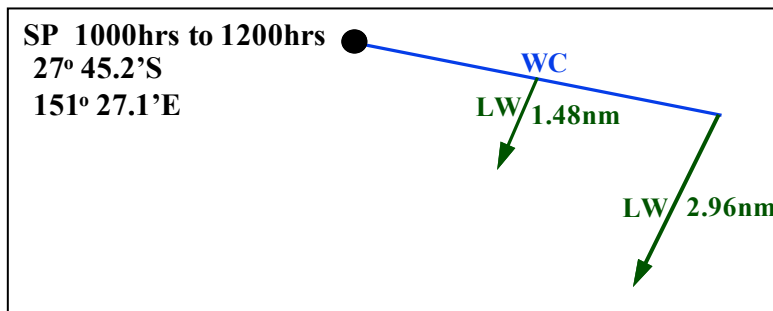


Diagram 22

5. Once both the WC and both LW legs have been plotted, draw a line from SP to through D1A to D1B. The name of the line is called the 'Total Drift' or 'Resultant'. Indicate the direction of travel with an

Appendices

arrowhead in the centre of the line. The TD line should touch the end of the shortest LW line. If it does not touch, or the LW is too long or too short, re-check the calculations. See Diagram 23 below.

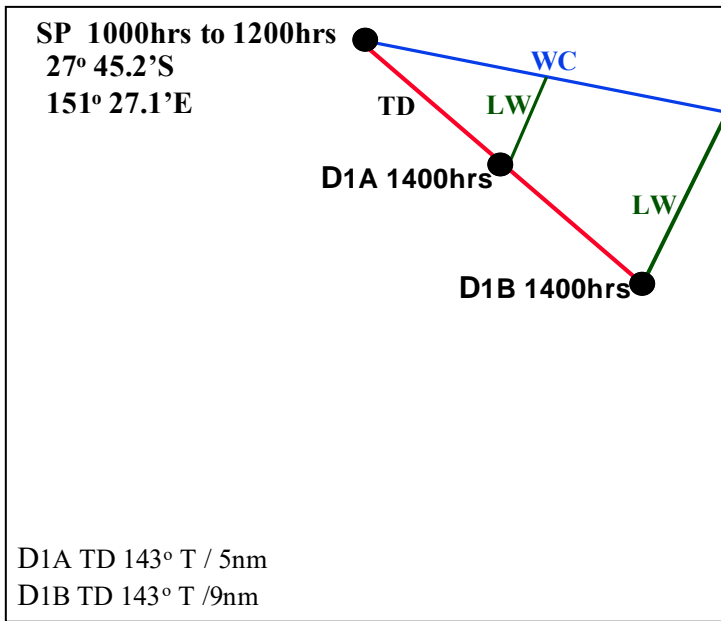


Diagram 23

6. D1A is plotted at the end of the first LW leg and D1B is plotted at the end of the longest LW leg. Note the direction of the TD line with a True bearing and distance.
7. The length of the TD line between SP and D₁B is 9 NM in this particular scenario. Therefore, the length of the TD line is divided by 8 and the result is added to the 6 NM radius circle, which is normally used. In this case the radius of the circle centred on datum D₁B is calculated as $9 \div 8 = 1.125$. $6 + 1.1 = 7.1$ NM. See Diagram 24 below.

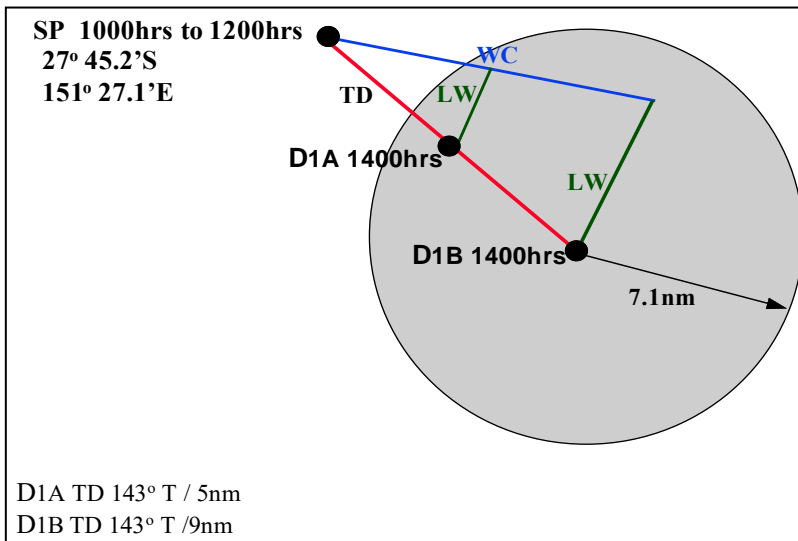


Diagram 24

8. The length of the TD line between SP and D1A is less than 8 NM in length. Therefore, a 6 NM radius circle is drawn centred on datum D1A. See Diagram 25 below.

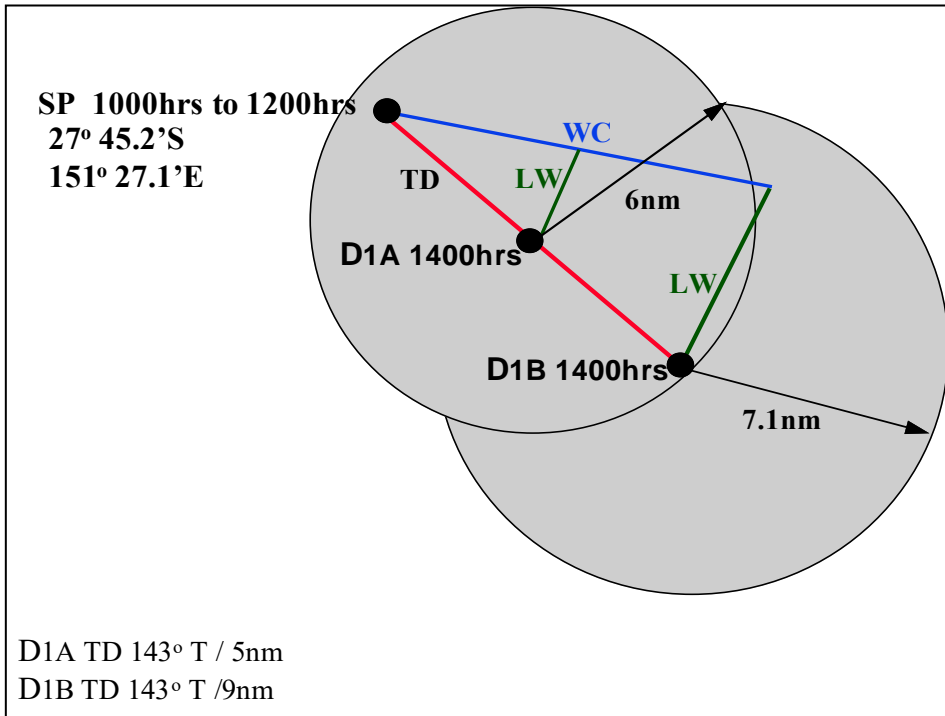


Diagram 25

- Once the circles are drawn, the area should be boxed, with the sides of the box touching the edges of the circles (tangential), and oriented in the direction of drift. This errs on the side of safety by building in a greater safety margin. See Diagram 26 below.

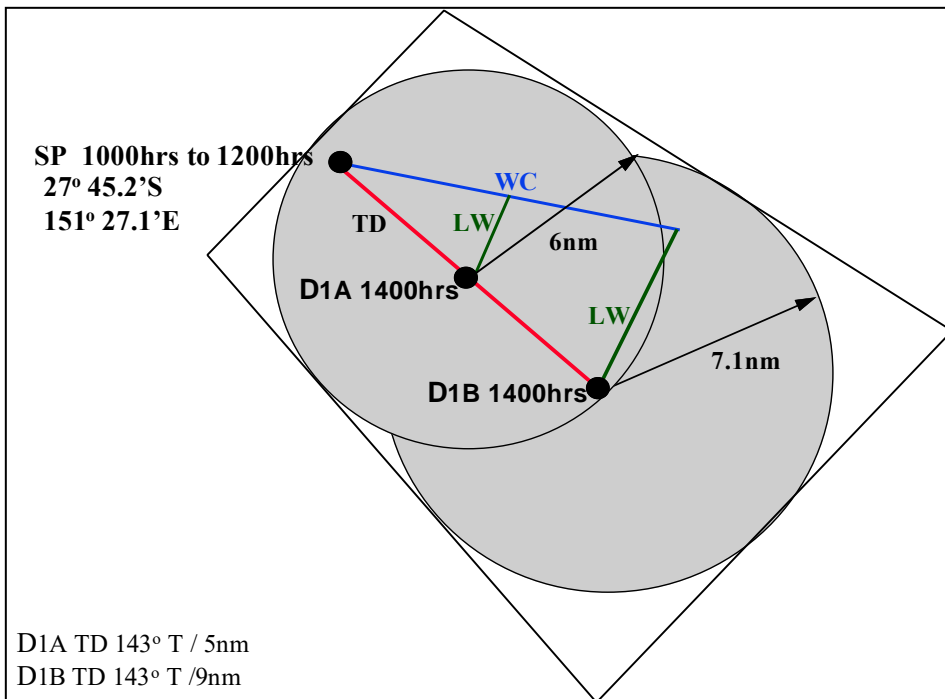


Diagram 26

- Assuming that the length of the TD line is less than 8 NM in length for both SP to D1A and SP to D1B, then a 6 NM radius circle is drawn centred on both datums, as indicated in Diagram 27 below.

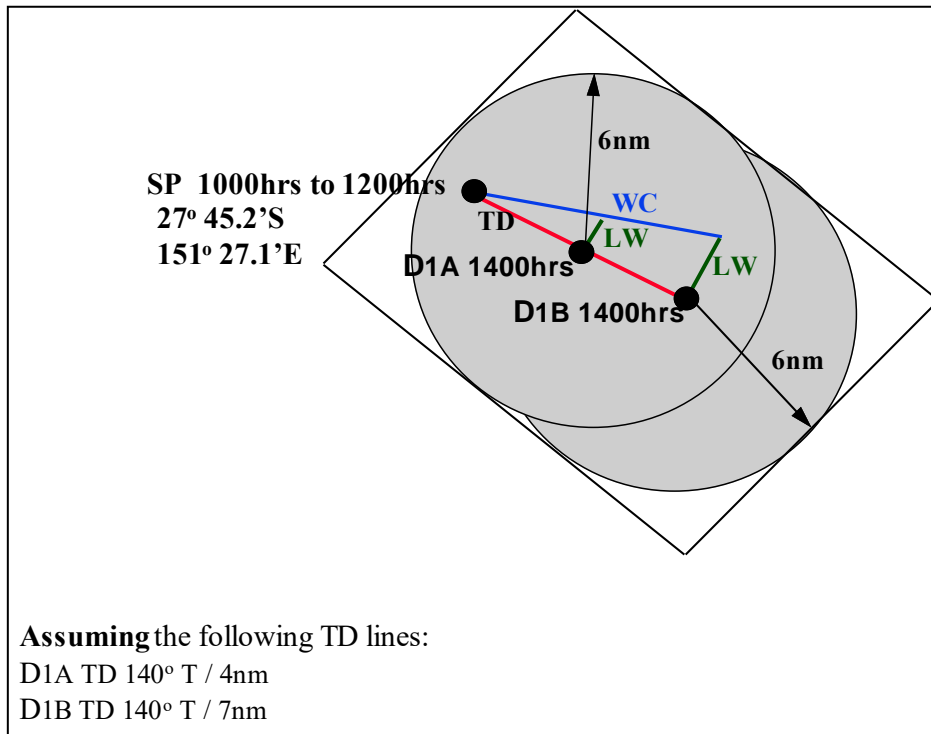


Diagram 27

Track Line Overdue

This is the most complex of all the datum SAR planning models. It is used when the track of the target is known

Datum should be calculated for a time when the search assets are likely to be on scene. There is no point in calculating datum if there are no resources in place to commence a search.

In the Track Line Overdue model, the departure point and arrival points are SPs. Along the target's intended track, the Co-ordinator may need to incorporate arbitrary turn points (e.g. to go around headlands etc.), there is no limit on the number of arbitrary turn points that can be incorporated into this model. See Diagram 28 below.

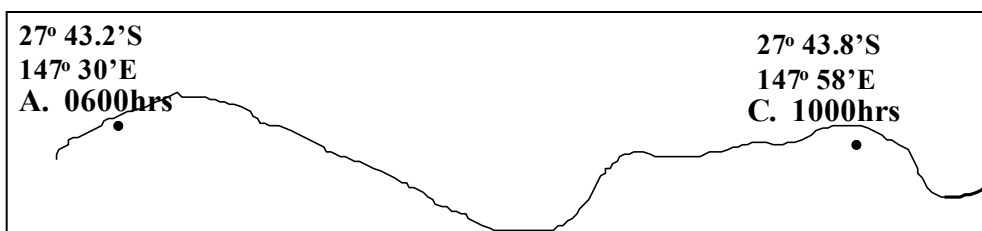


Diagram 28

For the purpose of this user guide the following example, with critical information, is used:

- Target**
Light Displacement Cabin Cruiser (Without Drogue).
- Cruise Speed**
The vessel's approximate speed in this case is 8 knots.
- Current**
192°T at 1 knot

d) **Wind**

318°T at 10 knots

e) **Splash Point**

Departure Point A - 27° 43.2' S 147° 30' E at 0600 hrs.

Arbitrary Turn Point B - 27° 43.5' S 147° 00' E at 0800 hrs.

Arrival Point C - 27° 43.8' S 147° 58' E at 1000 hrs.

In this case with a speed of 8 knots - Point A to B is 16 NM and Point B to C is 16 NM.

d) **Calculate a Datum for 1200 hrs**

Note:

- i. measure the route;
- ii. divide the distance by the vessel's approximate speed;
- iii. this will give the approximate time at the arbitrary turn point(s); and
- iv. this will also assist in confirming the intended arrival time.

Step-By-Step Guide

1. Do the calculations for each point separately. The points will need to be plotted. The chart and the distance of not only the intended track needs to be measured, but also the distance between each point.

If the time of departure and anticipated time of arrival can be ascertained, then the approximate speed of the vessel can be calculated. If not the cruising speed of the vessel will need to be estimated, taking into account the sea conditions, vessel type and power unit on board.

In this example the target departed Point A at 0600 hrs and was supposed to have arrived at Point C at 1000 hrs. Because there is a headland between Points A and C the target will have needed to have adjusted course on its intended track. Point B has been arbitrarily selected (it is a safe distance off the headland and one the target's skipper is likely to have taken).

The distance A to B to C has been measured and the target's cruise speed has been estimated. Based on the estimated cruise speed of the vessel, it would have reached Point B at 0800 hrs.

- a) Position A - point of departure at 0600 hrs (calculate to datum time of 1200 hrs)
 - i) 0600 hrs to 1200 hrs = 6 hrs
 - ii) WC 1 kt x 6 hrs = 6 NM
 - iii) LW 0.74 kt per hr x 6 hrs = 4.44 NM
- b) Position B - arbitrary turn point at 0800 hrs (calculate to datum time of 1200 hrs)
 - i) 0800 hrs to 1200 hrs = 4 hrs
 - ii) WC 1 kt x 4 hrs = 4 NM
 - iii) LW 0.74 kt per hr x 4 hrs = 2.96 NM
- c) Position C - arrival point at 1000 hrs (calculate to datum time of 1200 hrs)
 - i) 1000 hrs to 1200 hrs = 2 hrs
 - ii) WC 1 kt x 2 hrs = 2 NM
 - iii) LW 0.74 kt per hr x 2 hrs = 1.48 NM

Calculations for the example based on the following:

- a) WC 192°T at 1 knot per hour multiplied by the number of hours adrift.
- b) Wind 318°T at 10 knots.

Using the Formula $[(0.07 \times 10 \text{ kt}) + 0.04] = .74 \text{ NM per hour}$, multiplied by the number of hours adrift.

2. Points A, B and C have been plotted on the chart and the intended track drawn in. It is important to check to see whether there is an opportunity for the target to have anchored, sought shelter in ports or taken made any likely deviations from the intended course (e.g. to visit a scenic island or beach) etc. See diagram 29 below.

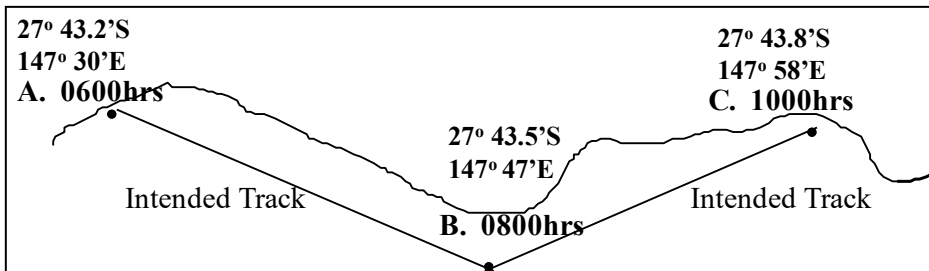


Diagram 29

3. Once both the WC and both LW legs have been plotted for the first datum, draw a line from SP to D1A. The name of the line is called the 'Total Drift' or 'Resultant'. Indicate the direction of travel with an arrowhead in the centre of the line. Note the bearing and distance of the TD line. See Diagram 30 below.

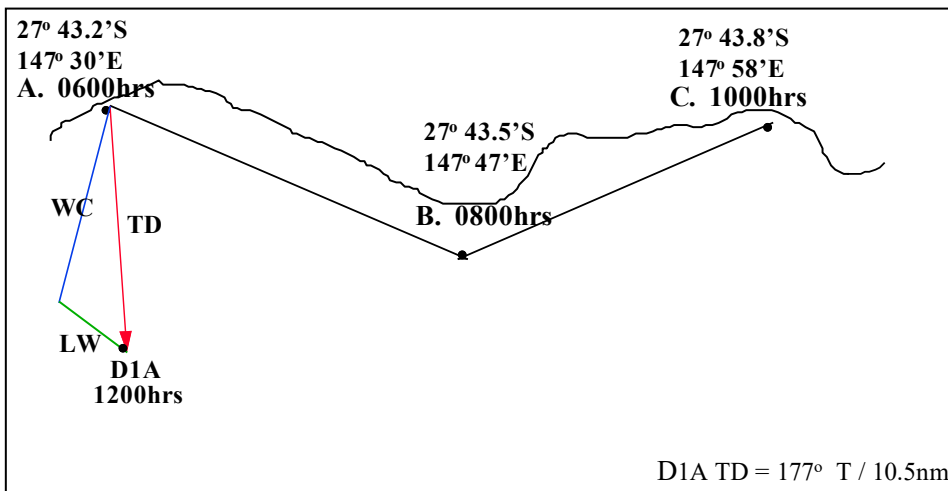


Diagram 30

4. Once both the WC and both LW legs have been plotted for the second datum, draw a line from SP to D1B. The name of the line is called the 'Total Drift' or 'Resultant'. Indicate the direction of travel with an arrowhead in the centre of the line. Note the bearing and distance of the TD line. See Diagram 31 below.

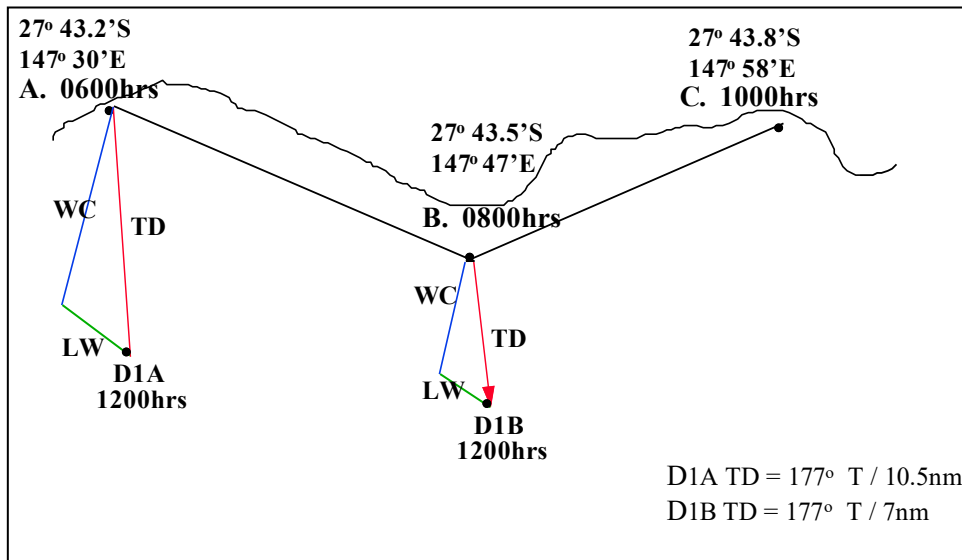


Diagram 31

- Once both the WC and both LW legs have been plotted for the third datum, draw a line from SP to D1C. The name of the line is called the 'Total Drift' or 'Resultant'. Indicate the direction of travel with an arrowhead in the centre of the line. Note the bearing and distance of the TD line. See Diagram 32 below.

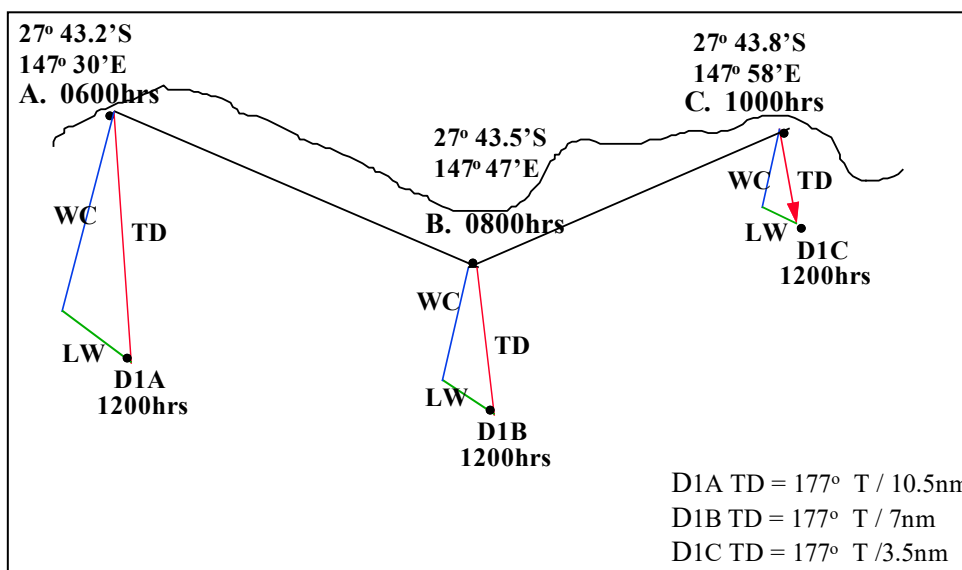


Diagram 32

- Once all three datums have been plotted, draw a line connecting all three datum points. The name of the line is called the 'Datum Line'. See Diagram 33 below.

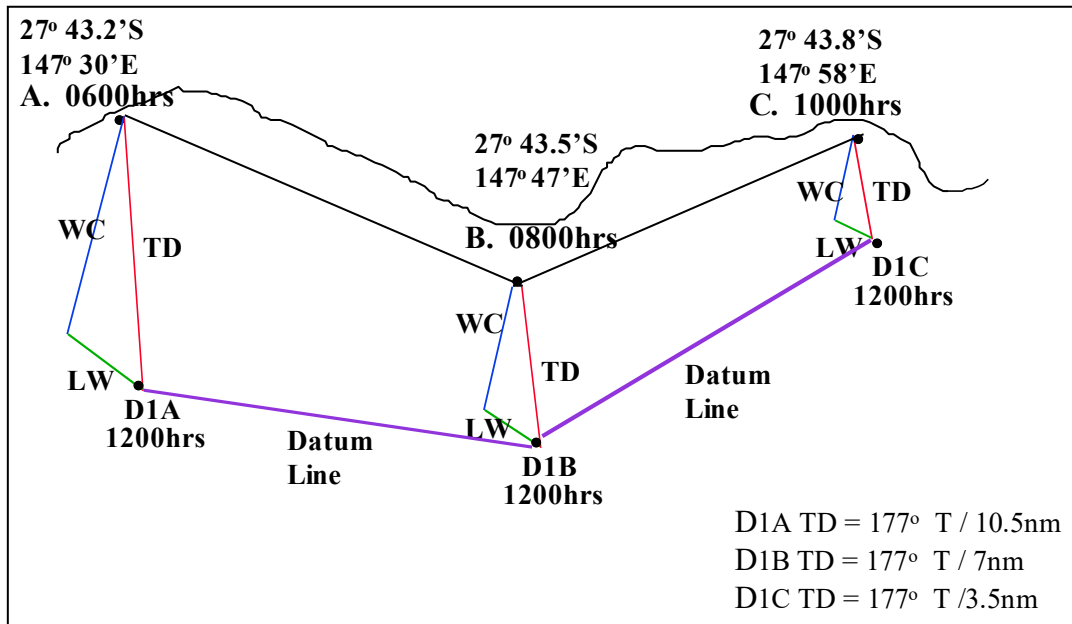


Diagram 33

7. A circle is drawn centred on datum (a 6 NM radius circle is used if the TD line is less than 8 NM in length). In this case the TD line between SP A and D1A is 10.5 NM. Therefore, the individual drift error must be applied, $10.5 \div 8 = 1.3125$. The radius of the circle drawn centred on D1A is $6 + 1.3 = 7.3$ NM. As indicated in Diagram 34 below.

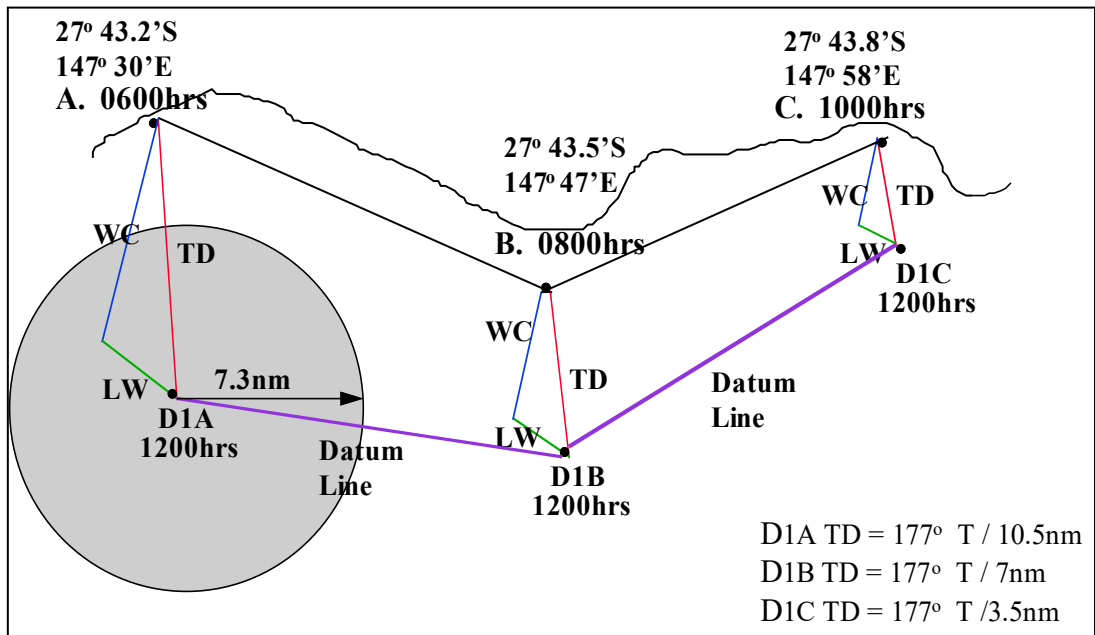


Diagram 34

8. The length of the TD line between SP B and D1B is 7 NM in length, therefore individual drift error does not apply. A 6 NM radius circle is drawn centred on datum D1B. See Diagram 35 below.

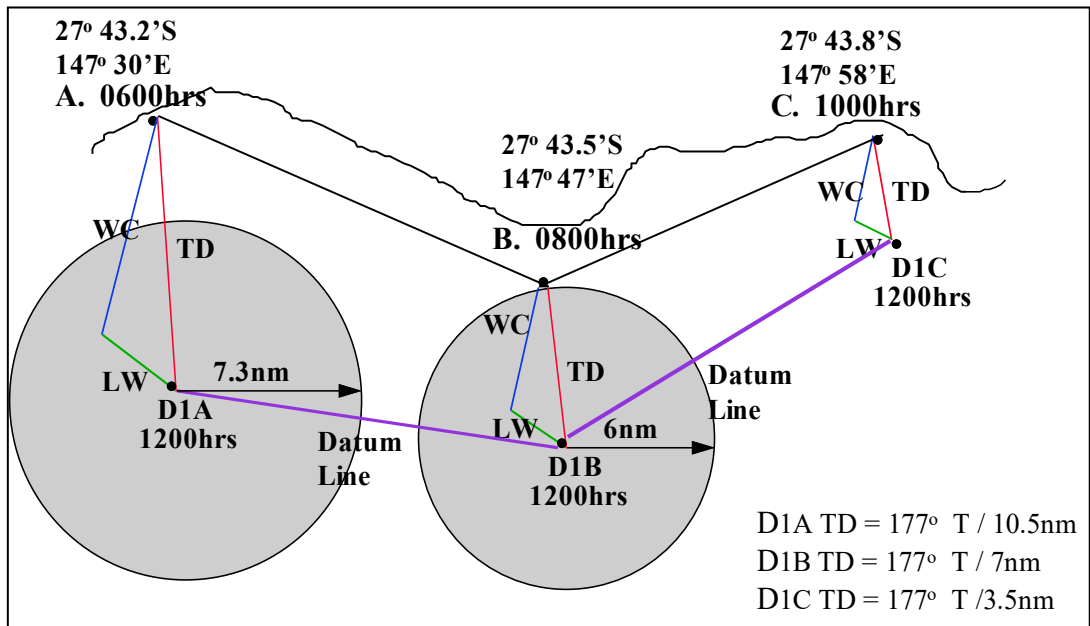


Diagram 35

- The length of the TD line between SP C and D1C is 3.5 NM in length, therefore individual drift error does not apply. A 6 NM radius circle is drawn centred on datum D1C. See Diagram 36 below.

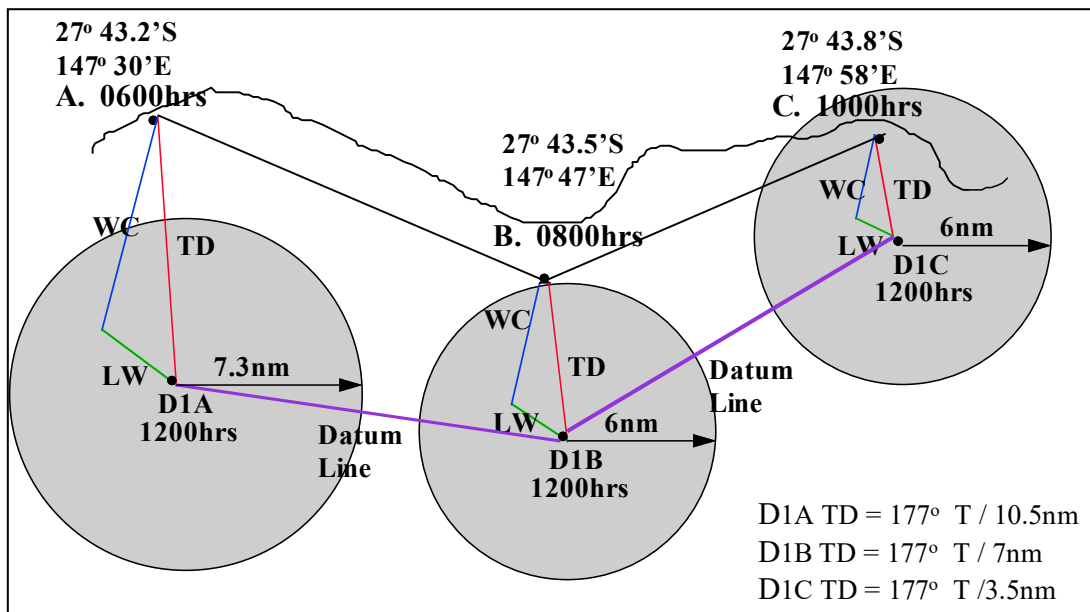


Diagram 36

- Once the circles are drawn, the area should be boxed, with the sides of the box touching the edges of the circles (tangential), and oriented in the direction of drift. This errs on the side of safety by building in a greater safety margin. See Diagram 37 below.

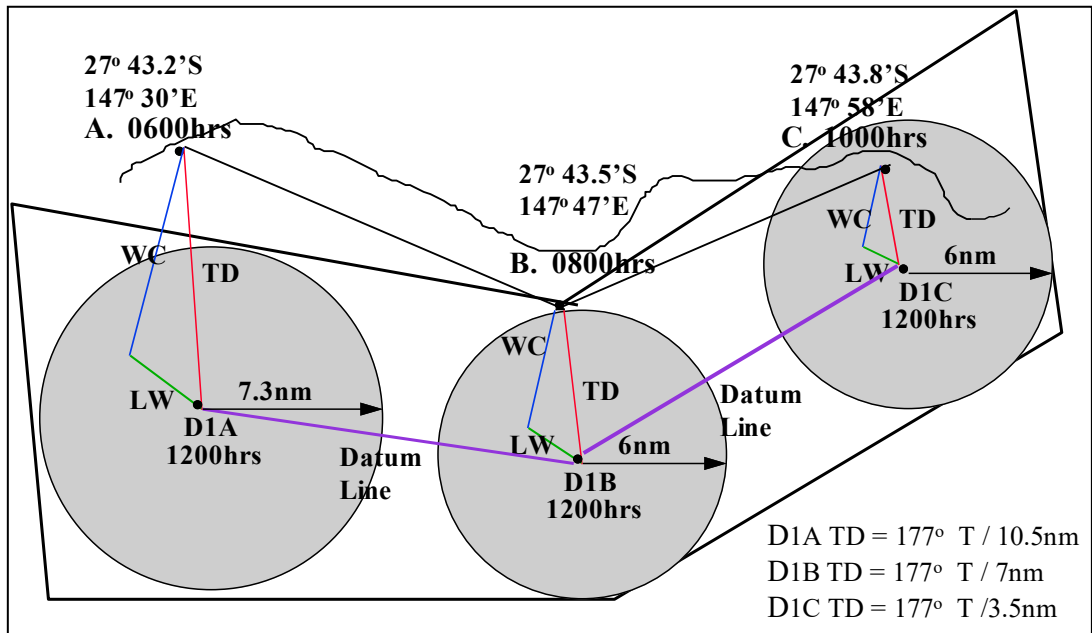


Diagram 37

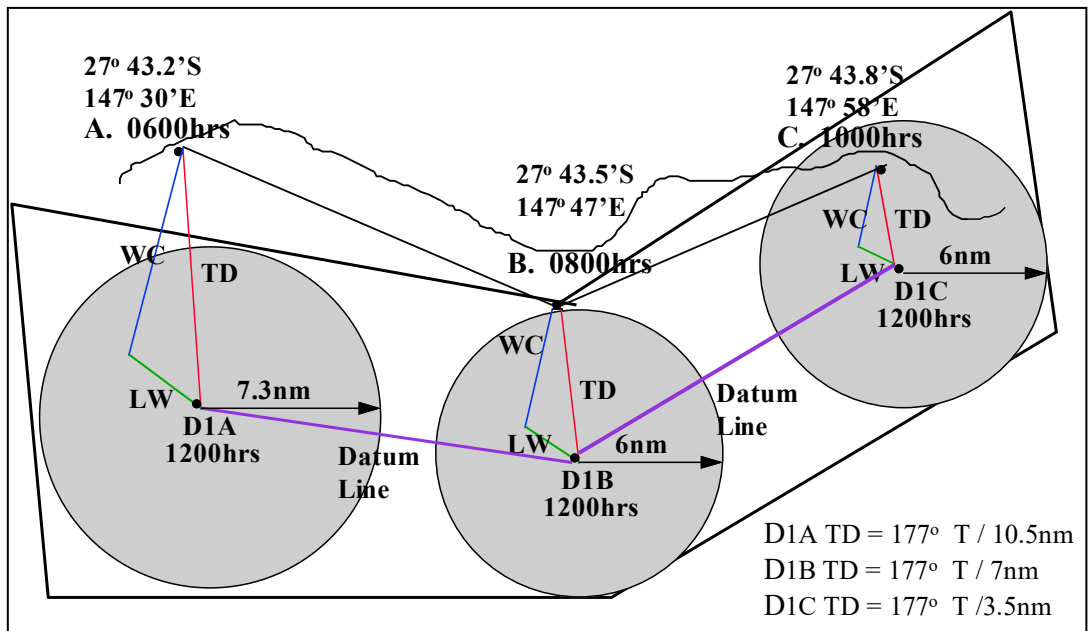


Diagram 38

11. The shaded area in Diagram 38 on the next page, is the area of high probability. It does not mean than you can discount areas outside of this initial search area.

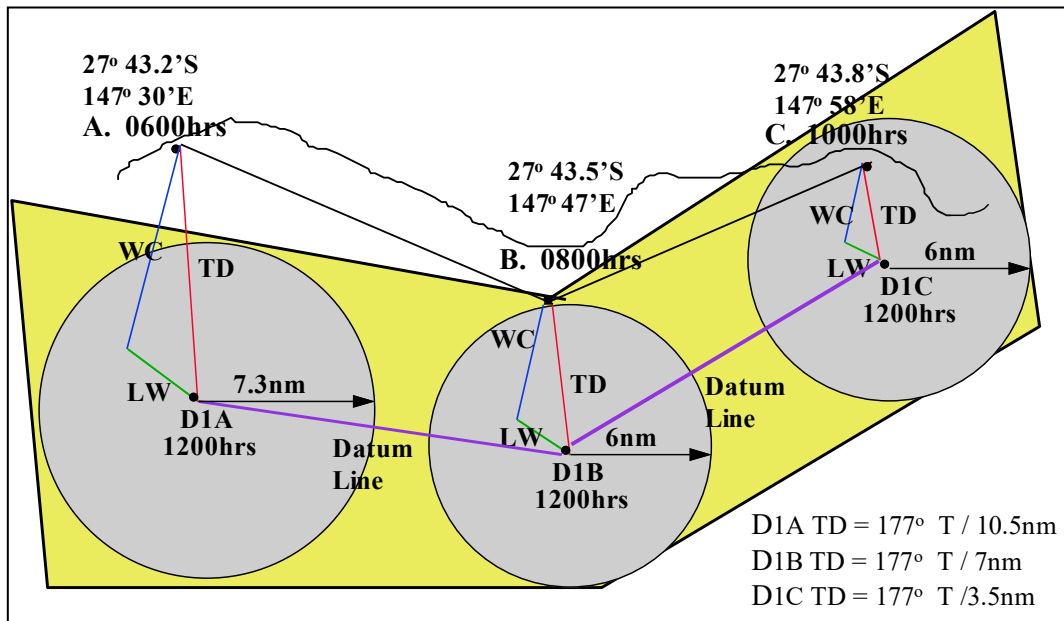


Diagram 39

12. There may cases where the area to be searched may need to be 'stretched'. Diagram 39 below gives such an example where the search area has been stretched back to the mainland. At one end of the search area the foreshores are covered, at the other end they are not, but are close enough that they should be searched.

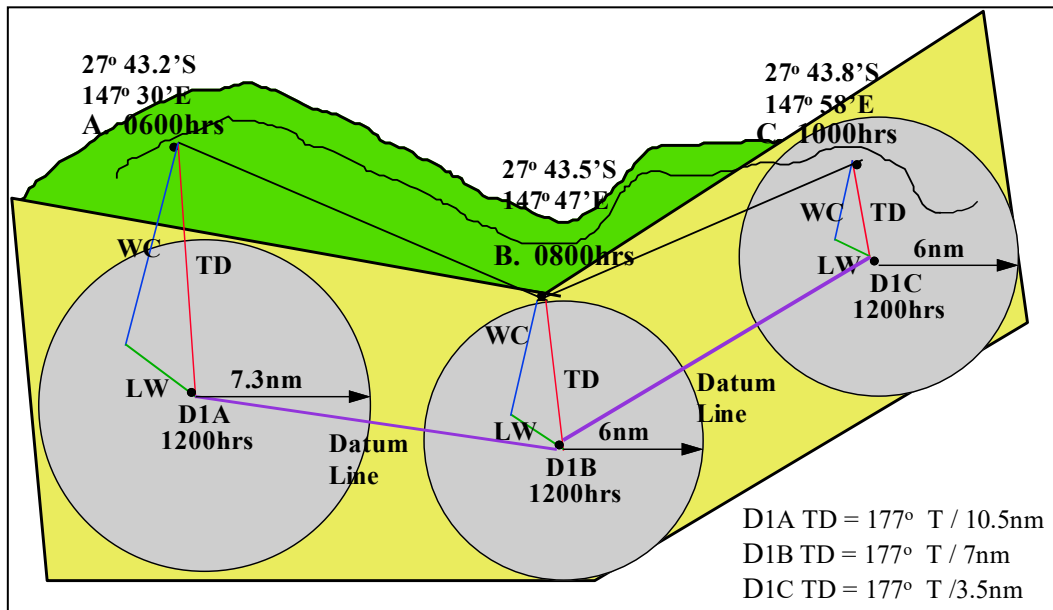


Diagram 40

13. In some cases, it may be necessary to draw a 6 NM radius circle centred on each on each SP. Especially where there are confused currents, water flows, eddies around reefs, islands or there is intelligence that indicates that there is a possibility that the target may be taken out the back of the search area. See Diagram 40 below.

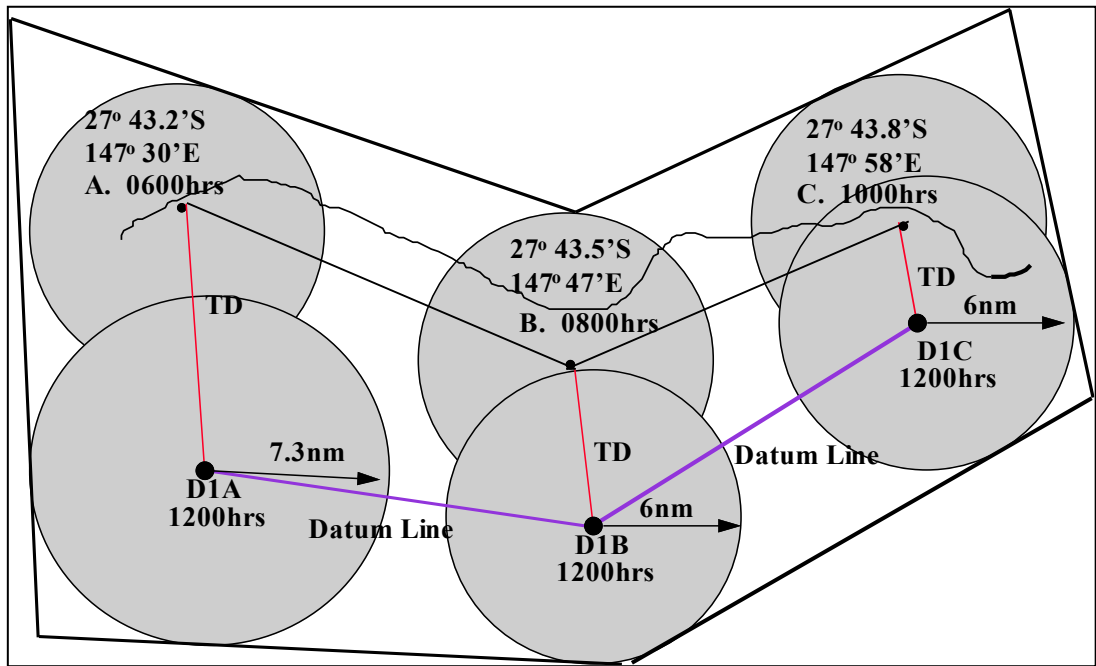


Diagram 41

14. Assuming that the length of the TD line is less than 8 NM in length for SP A to D1A, SP B to D1B and SP C to D1C then a 6 NM radius circle is drawn centred on all datums, as indicated in Diagram 41 below.

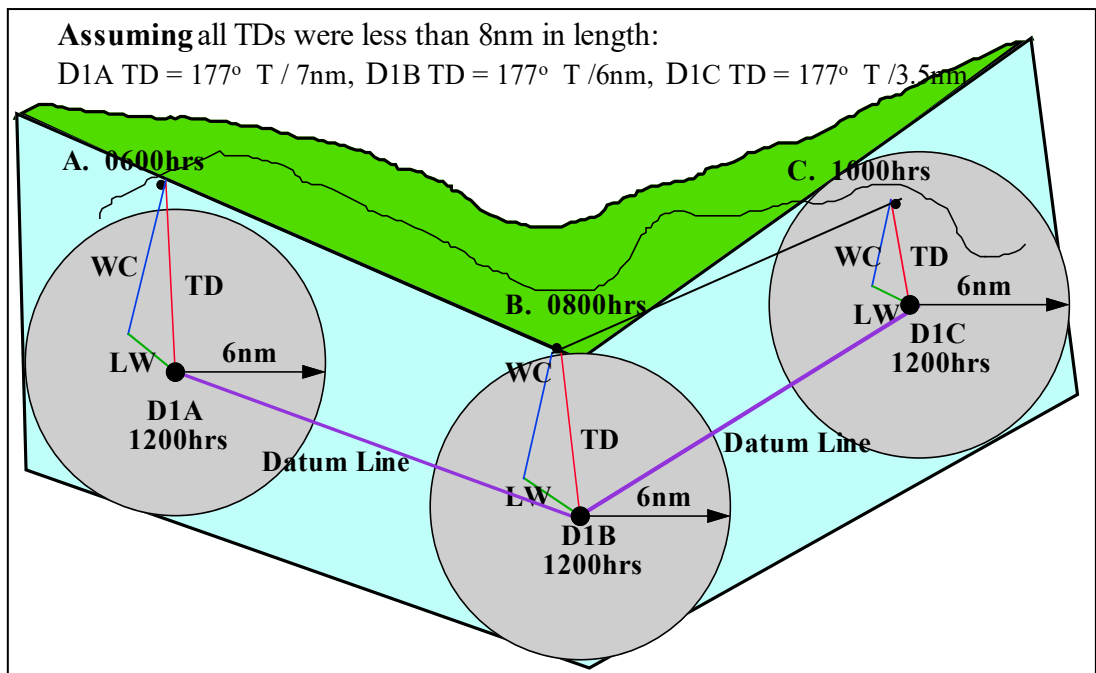


Diagram 42

Multiple Winds

This model is used when the water current is consistent, yet the wind direction and velocity may have varied between the time the target got into trouble and the time datum is calculated for.

Datum should be calculated for a time when the search assets are likely to be on scene. There is no point in calculating datum for a specific time, if there will be no resources in place to commence a search at this time.

For the purpose of this user guide the following example, with critical information, is used:

- a) **Target**
Light Displacement Cabin Cruiser (Without Drogue).
- b) **Current (WC)**
1 knot South Easterly (towards the S.E.)
135° T at 1 kt per hour. 1 kts x 3 hrs = 3 NM for the water current leg
- c) **Wind**
Varied (see diagram 1 below)
- d) **Splash Point**
27° 31.5' S 147° 30' E at 1300 hrs
- e) **Calculate a Datum for 1600 hrs**
The search will commence at this time
- f) **Wind**
To calculate the leeway applicable to the target: $0.07U + 0.04 =$ the rate (kts).
- g) **Total hours adrift**
3 hours

Step-By-Step Guide

1. The table in diagram 42 below has been designed to assist SAR trained personnel to calculate the various legs to plot in datum SAR planning. The form is split into two components, Leeway (LW) and Water Current (WC).

Leeway component of the form

Wind Times - From - To	Enter here the time the wind starts to the time it shifts. Thereby showing a period of time for a wind blowing from a given direction. Can also be used where the wind is blowing at a relatively constant speed for a given period of time and then increases for another period of time to a higher relatively constant speed. Two entries can be made.
Wind Direction / Speed	Show here the direction wind is blowing from and the speed in knots.
Leeway direction + 180°	Add 180° to the wind direction in the previous column. This will give you the vector to plot. Remember there can only be 360° in a circle (obvious, but mistakes can be made).
Leeway rate per hr	By using the Leeway Tables. Calculate the leeway speed (kts) per hour and enter in this column.

Time interval	Referring to “Wind Times -From - To” calculate the period of time the wind had been blowing in hours and decimals of an hour for this particular entry.
Vector to plot	Enter the direction calculated in column “Leeway direction + 180°”. Then multiply the “Leeway rate per hr” by the “Time interval”. The result, is the amount of leeway effect caused by this period of wind for that specific period of time.

Current

Time - From - To	Enter here the time the water current starts to affect the target to the time it shifts. Thereby showing a period of time for a current setting towards a given direction. Can also be used where the current is at a relatively constant speed for a given period of time and then increases for another period of time to a higher relatively constant speed or changes direction. Two entries can be made.
Direction/Speed	Calculate the water current direction and speed (kts) per hour and enter in this column.
Time interval	Referring to “Time -From - To” calculate the period of time the current has been flowing in hours and decimals of an hour for this particular entry.
Vector to plot	Enter the direction calculated in column “Direction/Speed”. Then multiply the speed of the current by the “Time interval”. The result, is the amount of current effect caused by this period of current flow for that specific period of time.

Leeway (Formula $0.07U+0.04$)

Wind Times From	Wind Times To	Wind Direc / Speed	Leeway direction +180	Leeway rate per hr	Time interval	Vector to plot
1300	1330	280° / 18	100°	1.3	.5	100° / .65nm
1330	1500	250° / 20	070°	1.44	1.5	070° / 2.16nm
1500	1600	230° / 20	050°	1.44	1.0	050° / 1.44nm

Current

Time		Direction/Speed	Time Interval	Vector to plot
From	To			
1300	1600	135° / 1	3	135° / 3nm

Diagram 42

- Plot the Splash Point (SP) on the chart and notate as shown below in diagram 2. Splash point can also be known as Last Known Position (LKP) or Initial Planning Position (IPP). Plot the Water Current (WC) leg first.

Plot the Leeway legs (LW) second. These legs commence at the end of the WC leg. See Diagram 43 below.

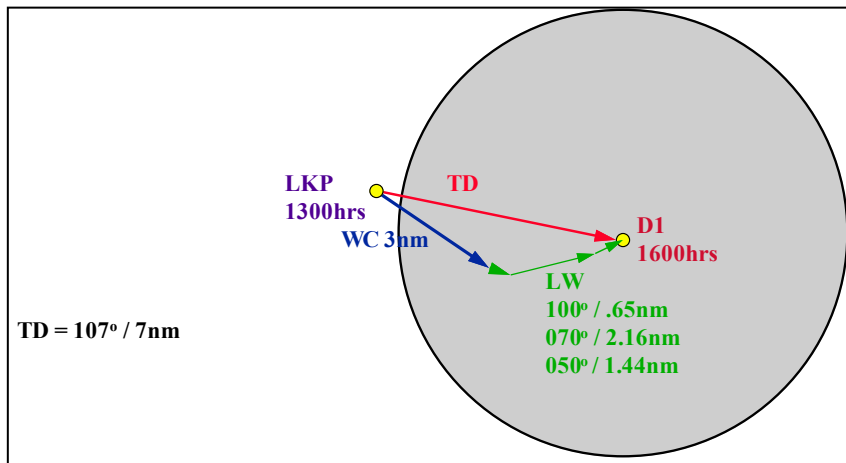


Diagram 43

3. Once the circle is drawn, the area should be boxed, with the sides of the box touching the edges of the circle (tangential), and oriented in the direction of drift. This errs on the side of safety by building in a greater safety margin.

Multiple Current and Winds

This model is used when the water current and wind direction/velocity may have varied between the time the target got into trouble and the time datum is calculated for.

For the purpose of this user guide the following example, with critical information, is used:

- a) **Target**
Light Displacement Cabin Cruiser (Without Drogue).
- b) **Current (WC)**
1 knot, South Easterly (towards the S.E.)
135° T at 1 kt per hour. 1 kt x 3 hrs = 3 NM for the water current leg
- c) **Wind**
Varied (see diagram 1 below)
- d) **Splash Point**
27° 31.5' S 147° 30' E at 1300 hrs
- e) **Calculate a Datum for 1600 hrs**
The search will commence at this time
- f) **Wind**
To calculate the leeway applicable to the target: $[(0.07U) + 0.04] = \text{kts}$.
- g) **Total hours adrift**
3 hours

Step-By-Step Guide

1. The table in diagram 44 below has been designed to assist SAR trained police officers to calculate the various legs to plot in datum SAR planning. The form is split into two components, Leeway (LW) and Water Current (WC).

Leeway component of the form

Wind Times - From - To	Enter here the time the wind starts to the time it shifts. Thereby showing a period of time for a wind blowing from a given direction. Can also be used where the wind is blowing at a relatively constant speed for a given period of time and then increases for another period of time to a higher relatively constant speed. Two entries can be made.
Wind Direction / Speed	Show here the direction wind is blowing from and the speed in knots.
Leeway direction + 180°	Add 180° to the wind direction in the previous column. This will give you the vector to plot. Remember there can only be 360° in a circle (obvious, but mistakes can be made).
Leeway rate per hr	By using the Leeway Tables. Calculate the leeway speed enter in this column.
Time interval	Referring to “Wind Times -From - To” calculate the period of time the wind had been blowing in hours and decimals of an hour for this particular entry.
Vector to plot	Enter the direction calculated in column “Leeway direction + 180°”. Then multiply the “Leeway rate per hr” by the “Time interval”. The result, is the amount of leeway effect caused by this period of wind for that specific period of time.

Current

Time - From - To	Enter here the time the water current starts to affect the target to the time it shifts. Thereby showing a period of time for a current setting towards a given direction. Can also be used where the current is at a relatively constant speed for a given period of time and then increases for another period of time to a higher relatively constant speed or changes direction. Two entries can be made.
Direction/Speed	Calculate the water current direction and speed per hour and enter in this column.
Time interval	Referring to “Time -From - To” calculate the period of time the current has been flowing in hours and decimals of an hour for this particular entry.
Vector to plot	Enter the direction calculated in column “Direction/Speed”. Then multiply the speed of the current by the “Time interval”. The result, is the amount of current effect caused by this period of current flow for that specific period of time.

Leeway (Formula $0.07U+0.04$)

Wind Times From	Wind Times To	Wind Direc / Speed	Leeway direction +180	Leeway rate per hr	Time interval	Vector to plot
1300	1330	280° / 18	100°	1.3	.5	100° / .65nm
1330	1500	250° / 20	070°	1.44	1.5	070° / 2.16nm
1500	1600	230° / 20	050°	1.44	1.0	050° / 1.44nm

Current

Time		Direction/Speed	Time Interval	Vector to plot
From	To			
1300	1400	135° / 1	1	135° / 1nm
1400	1600	150° / 1	2	150° / 2nm

Diagram 44

- Plot the Splash Point (SP) on the chart and notate as shown below in diagram 2. Splash point can also be known as Last Known Position (LKP) or Initial Position (IP). Plot the Water Current (WC) legs first. The reason for this is that if there is a possibility that the target is a person in the water, then the end of the WC legs becomes datum (D1).

Plot the Leeway legs (LW) second. These legs commence at the end of the last WC leg. See Diagram 45 below.

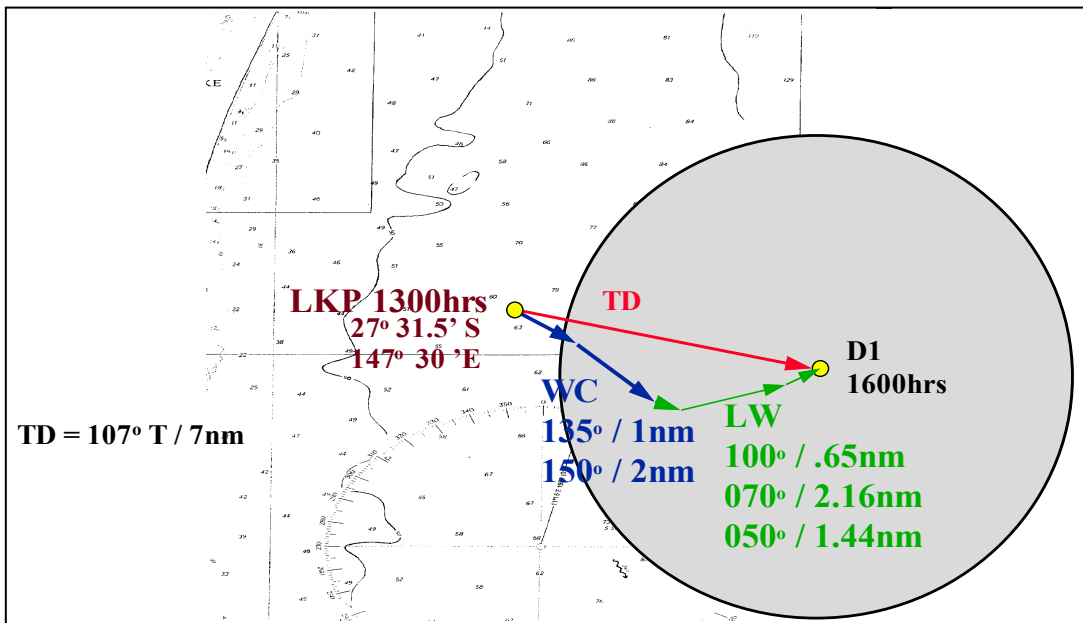


Diagram 45

- Once the circle is drawn, the area should be boxed, with the sides of the box touching the edges of the circle (tangential), and oriented in the direction of drift. This errs on the side of safety by building in a greater safety margin.

Appendices

Appendix E

Overview

Appendix E includes the following:

- Appendix E-1 Search Urgency Form
- Appendix E-2 Missing Persons Questionnaire
- Appendix E-3 Object Questionnaire
- Appendix E-4 Land SAR Checklist
- Appendix E-5 Lost Person Behaviour
- Appendix E-6 Land Search Planning Tables
- Appendix E-7 Additions to Naismith's Rule
- Appendix E-8 Probability of Detection (Land)
- Appendix E-9 Mattson Consensus
- Appendix E-10 Land SAR Organisation Chart
- Appendix E-11 FSH Layout
- Appendix E-12 Search Communication Network
- Appendix E-13 Clue Recognition
- Appendix E-14 SAR Tasking Sheet
- Appendix E-15 Search for Skeletal Remains
- Appendix E-16 Peer Review
- Appendix E-17 Body Flotation Information

Appendix E-1 Search Urgency Assessment Form

Search Urgency Assessment

Name of Incident:			No:
Date Completed:	Time completed:	Initials:	Incident date:

Number of subjects		
1 person	1	
2 people or 3 or more – separated	2	
3 people or more – together	3	
Age		
Very young	1	
Other	2-4	
Very Old	1	
Medical Condition		
Known illness or requires medication	1	
Suspected illness or injury	1	
Healthy	3	
Known frailty	1	
Potential vision impairment	1	
Intent		
Suicidal	1	
No known intent	3	
Absconder from facility	4	
Cognitive Capacity		
Dementia / Alzheimer's /Parkinson's	1	
Capacity of 16-year-old or less	1	
Diagnosed mental illness, depression or anxiety	2	
No known capacity issues	3	
Experience profile		
Not experienced – not familiar with area	1	
Not experienced – familiar with area	2	
Experienced – not familiar with area	3	
Experienced – familiar with area	4	
Physical Condition		
Unfit	1	
Fit	2	
Very fit	3	
Clothing profile		
Inadequate/insufficient	1	
Adequate	2	
Very good	3	
Equipment Profile		
Inadequate for activity/environment	1	
Questionable	2	
Adequate	3	
Very Well equipped	4	
Weather profile		
Existing Hazardous weather	1	
Hazardous forecast (8 hours or less)	2	
Hazardous forecast (more than 8 hours)	3	
No hazardous weather forecast	4	
Terrain and Hazards profile		
Known hazards	1	
Difficult terrain	2	
Few hazards	3	
Easy terrain, no known hazards	4	
11-17 Emergency Response 18-27 Measured response 28-39 Evaluate & Investigate		
Note: If any individual category above is rated as ONE (1) , regardless of its total – the search could require an emergency response		
Remember: the lower the number the more urgent the response!!!		

Appendices

Notes: The SUA should be completed by the SMC. When completing the SUA form please look at the SAR incident in its entirety to get a better understanding of the urgency involved.

An example of this may be a reported overdue skier in the alpine region of NSW. Making the assessment based on the activity that was being undertaken may provide a higher score than the actual situation requires. For the skiing activity the MP may be experienced and familiar with the area, scoring a 4. If they are overdue and the likelihood of them spending the night above the snow line is a possibility a re-assessment should be made. While they may be experienced to ski the various runs, they may have little or no experience at overnighting, dropping the score down to a 1.

If the MP was prepared for a day of skiing the popular ski runs with appropriate clothing, there is little likelihood that they took additional clothing for an overnight stay, again dropping the score from a 3 to a 1. Equipment is the same as clothing; a day skier is not likely to be carrying a tent and overnight provisions but may be perfectly equipped for a day ski.

The weather and hazard profile are similar in context. Weather and hazards in one area of the alpine region may be different in another area, and both can change during the course of a single day. A pleasant day of skiing can change in an instant, be aware of this and review the SUA form as appropriate.

It is appropriate for the SMC to ask the question of why the MP did not return from a scheduled activity, and from that make deductions on the potential possibilities and what the SAR response should be.

Appendix E-2 Missing Person Questionnaire

Missing Person Questionnaire									
Incident:				Date:			Time:		
Surname:					Given names:				
Address:						Telephone:			
						Mobile:			
DOB:				Ethnicity:			Sex:		
NOK:						Telephone:			
Hgt:	Wgt:	Bld:	Eyes:	Cmp:	Beard:	Scars:	Hair:	Lgth:	
Hiker Exp:			Climber Exp:			Swim Exp:			
Snow Exp:			Military Exp:			Camping Exp:			
First Aid Trn:			Map/Compass Trn:			Knowledge of area:			
Smoke:	Drink:	Fears:	Lost before:	Action then:					
Shirt:	Jumper:	Trousers:	Jacket:	Raingear:	Hat:				
Shoes:	Sole pattern:	Scarf:	Glasses:	Watch:	Jewellery:				
Other Clothing:						Clothes for dog scent:			
Pack:	Colour:	Tent:	Colour:	Slp Bag:	Colour:				
Water Bottle:	Colour:	Torch:	Colour:	Slp mat:	Colour:				
Knife:	Matches:	Compass:	Firearm:	Fishing gear:	Camera:				
Ropes:	Climb Equip:	Kayak:	Radio AM:	Radio CB:	PLB:				
Map:				Food:					
Name:	Scale:	Number:							
Vehicle Reg No:			Make/Model:			Colour:			
Medical History:			Physical Problems:			Psych Problems:			
Medication:			Amount carried:			Consequences:			
Doctor:			Address:			Telephone:			
Family Problems: (Financial, family)					Request for Aid (Welfare)				
Person to notify if found ALIVE:			Address:			Telephone:			
Person to notify if found DEAD:			Address:			Telephone:			
Remarks:									
Name:				Rank:			Station:		

Appendices

Appendix E-3 Object Questionnaire

Object Questionnaire			
SAR Number:		Date/Time:	
Description of Object: (If photo/drawing is available please attach)			
Make:	Model:	Reg/Serial No:	
Colour:	Dimensions:	Weight:	
Special Markings/Identifiers:			
Does this object pose any dangers to humans, animals or the environment? If so, describe in detail:			
Who can be contacted to provide expert advice?			
Name:	Organisation:	Telephone Number:	Fax No:
What action is to be taken by searchers if object found?			
Information provided by:			
Name:	Organisation:	Telephone Number:	Fax No:
Remarks:			
Name:	Rank:	Section/Station:	

Appendix E-4 Land SAR Checklist

Land SAR Checklist			
Maintain chronological action log: <i>(Who spoken to? Times, Dates)</i>			
Missing person Questionnaire:		Completed:	
Search Area:			
Terrain		Hazards	
Communications		Assessment of scenarios	
Availability of resources		What's been done to date	
Isolate/Contain area		Local SAR Plan	
Weather (www.bom.com.au)			
At present		Forecast	
Sunset/sunrise		Potential hazardous weather	
Search Urgency			
Complete Search Urgency Form		Determine appropriate response	
Update briefing to Insp/Sen Sgt/Duty Officer		Update JRCC	
Advise Media Section		Advise Coroner (If death)	
Advise SES and other resources			
Field Search Headquarters			
Set up Field Search Headquarters		Suitable location	
Access		Parking	
Transport		Communications	
Facilities		Equipment	
Missing Person Locations			
Confirm Initial Planning Point IPP		Last Known Point LKP	
Point Last Seen PLS			
Lost Person behaviour LPB			
Establish distances		Characteristics	
Likely search areas		Medical considerations	
TFFS		POM	
Mapping			
Suitable maps		Mark IPP, LKP, PLS	
Areas searched		Areas to be searched	
SITREPS:			
To local command		SAR Command	
OIC		Media	
NOK		Other agencies	
Planning:			
Identify Operations Commander (Liaise with same)		Identify SMC	
Search appreciation conducted		Designate sub roles	
A/SMC		Planning member	
Intelligence member		Log keeper	
Communications member		Logistics member	
Consider Criminal Investigation Branch if suspicious		NOK Liaison officer	
Establish White Board		Establish Communications Plan	
Updated weather information		Mapping/tasking	
Identify search areas (Manageable in 4-6 hrs)		Consider Mattson Consensus	
Allocate Operational periods for future taskings		Rescue Plan	
Allocate resources to teams		Brief Search Personnel	
Team leader Briefings			
SMEAC		Emphasise clues	

Appendices

Land SAR Checklist			
Calling method		Description/clothing	
Search method		SITREP requirements	
Questions? Understood		Rescue Plan	
Actions on			
Search patterns			
FAST Teams		Static Teams (SES Light trailer)	
Roadblocks		Patrols	
Track Traps		Broad Sweeps	
Sound Sweeps		Night Search	
Contact Search		Line (Parallel) Search	
Records			
Action log		Equipment issued log	
Radio log		Search team records	
Personnel records- Attendances		Intelligence Records	
Update Map/Chart/white boards		Daily summary of personnel	
Debrief			
Thoroughness of search		POD	
Mark searched areas on map		Team leader to sign search record	
Clues		Further areas to search	
Issues raised		Download GPS information	
Manage welfare			
Future Issues			
Allocate time callout for more resources		Search/rescue plans	
Evacuation plan		Operational periods	
Changeover of staff/SMC		Equipment/fuel	
Conclusion of SAR Operations -			
<i>At the conclusion of a SAR operation due to a target being located or the operation is suspended when a target is not located, the designated SMC should consider the following points and determine the correct course of action.</i>			
Confirm information is accurate and target has been located			<input type="checkbox"/>
Alert all SRU – Stand down units			<input type="checkbox"/>
Sign in all members and document any injuries			<input type="checkbox"/>
All appropriate agencies notified			<input type="checkbox"/>
Sitrep to local command			<input type="checkbox"/>
Log assets / resources <i>Equipment repair & return</i>			<input type="checkbox"/>
NOK Notified <i>Insure they are updated regularly. Appoint a liaison member Ensure active participation in process were possible Prepare NOK for suspension decision at least one day prior</i>			<input type="checkbox"/>
Consider bringing in coroner or coroner's assistant			<input type="checkbox"/>
Involve Police Investigators early - If MP not located			<input type="checkbox"/>
Consult Doctor – private and independent			<input type="checkbox"/>
Media release <i>Ensure you communicate correct message if SAR suspended. Seek advice from Police Media liaison unit Consider signs or pamphlets left in area – if target not located</i>			<input type="checkbox"/>
Debrief the MP – document / consider taping			<input type="checkbox"/>
Review who has command – If SMC leaving area			<input type="checkbox"/>
Hazards ID e.g. abandoned vessel – advised shipping			<input type="checkbox"/>
Records collated and filed			<input type="checkbox"/>

Land SAR Checklist	
If target not located – Document reasons for suspension <i>Document by - police statement or Specific suspension of SAR documentation</i> <i>Signed off by district officer or higher</i>	<input type="checkbox"/>
Administration / Financial procedures completed	<input type="checkbox"/>
Conduct & organize debriefs – Hot & Full	<input type="checkbox"/>
Ensure Debriefs documented – Action items identified <i>Improvements, what went well, further investigation, encourage feedback</i> <i>Designate actions items to specific members</i> <i>Full debrief with relevant team leaders within 2 weeks of conclusion</i>	<input type="checkbox"/>
Safety issues after search. Driving whilst tired / alcohol	<input type="checkbox"/>
Consider critical incident stress management issues	<input type="checkbox"/>
Letters of thanks to outside agencies <i>Certificates for good work</i>	<input type="checkbox"/>
Conduct review – conclusion or suspension of SAR operation <i>By SMC and independent member</i> <i>Examine search plan</i> <i>Review planning scenarios</i> <i>Confirm initial planning point</i> <i>Evaluated all intelligence</i> <i>Examine all calculations</i> <i>Consult other experts – Police/medical/JRCC</i> <i>Review TFFS with all available information</i> <i>Quality and effectiveness of search</i> <i>Consult doctor - personnel and independent</i> <i>Coverage of all areas searched</i> <i>POD high as desired</i> <i>Can you justify what has been done or not done?</i> <i>Never assume anything – information must be confirmed</i>	<input type="checkbox"/>
Consider – <i>Future Case study NATSAR</i> <i>Review NATSAR Manual Volume 2 Chapter 6 Conclusion of SAR Operations</i> <i>Exercises in area</i> <i>Over flights by Helicopter</i>	<input type="checkbox"/>
CONCLUSION OR SUSPENSION - NOT TERMINATION	
Resources	
JRCC	Local Police
Command Truck	Dog Squad
Mounted Unit	Radio Techs
Field Catering	Media Unit
Psychologist	Forensic Unit
Scenes of Crime Unit	JRCC
DACC	Ambulance
SES	Fire Service
Cave/Mine rescue	Salvation Army
Surf Life saving	Volunteer Marine Rescue
Coast Guard	Ski Patrol
Customs	BOM
Harbour master	

Appendices

Appendix E-5 Lost Person Behaviour

Overview

Lost Person Behaviour (LPB) has been derived from many studies and statistics gathering from search and rescue groups in many countries of the world. It has been found that certain categories of missing persons tend to have similar characteristics with respect to being lost. These categories have been broken down into the following groups:

- a) Children 1-3 years of age,
- b) Children 4-6 years of age,
- c) Children 7-12 years of age,
- d) Youths 13-15 years of age,
- e) Despondent or Suicide,
- f) Psychological Illness,
- g) Developmental Problems,
- h) Alzheimer's and Dementia,
- i) Hikers and Walkers,
- j) Climbers,
- k) Hunters,
- l) Prospectors,
- m) ADD, ADHD, Autism and Asperger's,
- n) First Nation People.

Lost Person Behaviour Definitions

Children 1-3yrs: All children aged 1-3 years of age.

Children 4-6yrs: All children aged 4-6 years of age.

Children 7-12yrs: All children aged 7-12 years of age.

Youths 13-15yrs: All teens aged 13-15 years of age.

Despondent: A person feeling or showing signs of profound hopelessness, dejection, discouragement and/or gloom. This includes depression and people who have expressed the intent to commit suicide. Not all despondent persons are suicidal and similarly not all suicidal persons are despondent, but they have similar characteristics and are therefore combined for SAR purposes.

Psychological Illness: This category covers persons suffering from a wide range of mental disorders that medically would not be used together. They include persons suffering from schizophrenia, paranoia, psychotic disorders and bipolar disorders. These disorders can be naturally occurring or artificially induced such as by substance abuse. This category does not include dementia.

Developmental Problems: Also called Mental Retardation or Intellectual disability is a combination of below average intellectual functioning, impairments in daily life (communication, self-care, social skills, work, safety, health) and was onset prior to the age of 18 years. This category also applies to persons suffering brain injuries after 18 years that exhibit the same symptoms.

Dementia: Dementia is the loss of memory, reason, judgement and language to such extent that it interferes with daily living. Dementia includes AIDS and Alcohol related dementia, Alzheimer's Disease, Down Syndrome, Early or Younger Onset Dementia, Fronto Temporal Lobar Degeneration, Vascular

Dementia and Dementia with Lewy bodies. Dementia often results in severe disturbances in how a person perceives and interprets events, sights, and sounds around them.

Hikers and Walkers: This category includes day walkers, members of bush walking clubs, hill/fell walkers, multi-day hikers, trekkers, orienteers and other persons who purposefully enter the bush for recreational walking purposes. Mountaineers are included in the climbing category.

Climbers: This category includes day climbers (single day outings, bouldering, rock and cliff climbers, traditional climbers and sport climbers) and mountaineers (those who attempt prominent peaks or alpine travel).

Hunters: This category includes all forms of hunting (pigs, water buffalo, brumbies, game fowl, kangaroos, cattle) on land. There is insufficient data for a further breakdown.

Prospectors: This category includes professional and amateur prospectors, regardless of what they are searching for (Gold, opal, gemstones etc.). It does not include geologists, surveyors or other professionals in the exploration industry.

Children with ADD, ADHD, Autism and Asperger's: This category includes all children who have been medically diagnosed with one or more of these conditions. It also includes children that are suspected of having one or more of these disorders but have not yet been diagnosed.

First Nation Persons: This includes all First Nation people who reside outside the major urban areas.

These are the most common groups of missing persons likely to be the subject of a search in Australia.

There have been numerous studies on missing person behaviour with the most recent being Robert Koester's (ISRID) International Search and Rescue Incident database www.dbs-sar.com collating thousands of incidents, statistics and previous studies for an international database. This information is continually being analysed and updated with Koester currently dividing missing person statistics to eco regions around the world that will enable more defined distances of travel for particular areas such as Victoria, a temperate terrain, as opposed to Northern Territory a hot dry terrain. The only specific Australian project on missing person behaviour was the SARBAYES project which was completed by Charles Twardy: <http://sarbayes.org/natsar.pdf>. The current Australian data base for the entry of LPB details is: <http://goo.gl/OLZmW>

Overseas studies also look at other categories such as hunters, skiers and miscellaneous adults. The three main LPB studies used for this manual have been taken from the UK, USA and Canada. Although Australia has many links with the UK and the majority of our citizens have a British background, we are a more mobile and active society more closely resembling Canada in our lost person behaviour. These tables have been prepared as a guide only and are a compilation of studies in the above countries. They represent the statistical properties and characteristics of missing persons and what could be expected of them when they are lost, but ultimately these are only probabilities, not certainties.

This information can be used as the basis of search planning when no other information is available. Obtaining a good profile of the target person will assist the SMC in determining whether that person/group fits into the known behavioural patterns of the various categories studied. If so, then further planning can be carried out on the information contained within this section. The SMC must always be aware that not everyone will adhere to these profiles. As can be seen in the distances travelled, 80% are within a relatively small area while the last 20% of persons in each category tend to travel much greater distances.

The studies show what the majority will do, there will always be someone outside the box who will do the opposite of what is expected.

Children 1-3 years

Children 1-3 years															
<p>Characteristics: 1–3-year-olds</p> <ol style="list-style-type: none"> Have no concept of being lost. Navigational skills are non-existent. Will appear to wander aimlessly, although studies suggest that there may be a plan only known to them. Will not often respond to commands or whistles. Will tend to find shelter, which increases their survivability. 															
<p>Tendencies:</p> <ol style="list-style-type: none"> Will often seek out a place of shelter. Thick bushes, tables, old vehicles or appliances, caves. Difficult to detect. Will rarely self-help or walk out. 															
<p>Strategies:</p> <ol style="list-style-type: none"> Urgent response due to their vulnerability to the environment (Pools, ponds, dams, weirs, creeks, rivers and other waterways are a priority). Confinement is a low priority. Passive techniques are not often successful. Dogs may be helpful if used quickly, but do not delay searching to wait. Checks of places of highest probability to be made initially. Teams to run main tracks and trails. May require getting down onto hands and knees to identify other less obvious tracks. 															
<p>Where located statistically:</p> <table border="0"> <tbody> <tr> <td>a. Habitation</td> <td>27%</td> </tr> <tr> <td>b. Building/shelter</td> <td>26%</td> </tr> <tr> <td>c. Open ground</td> <td>23%</td> </tr> <tr> <td>d. Linear feature (Fence, hedge)</td> <td>12%</td> </tr> <tr> <td>e. Water, water's edge</td> <td>12%</td> </tr> </tbody> </table>						a. Habitation	27%	b. Building/shelter	26%	c. Open ground	23%	d. Linear feature (Fence, hedge)	12%	e. Water, water's edge	12%
a. Habitation	27%														
b. Building/shelter	26%														
c. Open ground	23%														
d. Linear feature (Fence, hedge)	12%														
e. Water, water's edge	12%														
% of category	25%	50%	75%	80%	95%										
Distance from LKP (Km)	0.27	0.6	1.7	2.0	4.45										

Children 4-6 years

Children 4-6 years					
Characteristics: 4–6-year-olds					
<ul style="list-style-type: none"> f. Have an idea of being lost and will endeavour to return to home or to a familiar place. g. Will panic, which may cause them to become further lost. h. Explorations are usually one way. This is a result of not comprehending to need to make a return journey. i. Will tend to remain on tracks or what they perceive as tracks. Not always visible to taller adults. j. Are considerably more mobile than smaller children. k. May have been following an adult or animal prior to getting lost. 					
Tendencies:					
<ul style="list-style-type: none"> a. Will often seek out a place of shelter. Thick bushes, tables, old vehicles or appliances, caves. b. Difficult to detect. c. Will rarely self-help or walk out. 					
Strategies:					
<ul style="list-style-type: none"> a. Urgent response due to their vulnerability (Pools, ponds, dams, weirs, creeks, rivers and other waterways are a priority). b. Confinement is a low priority. c. Passive techniques are not often successful (Consider nicknames or favourite music). d. Dogs may be helpful if used quickly, but do not delay searching to wait. e. Checks of places of highest probability to be made initially. f. Teams to run main tracks and trails. g. May require getting down onto hands and knees to identify other less obvious tracks. 					
Where located statistically:					
<ul style="list-style-type: none"> a. Habitation 29% b. Building/shelter 28% c. Road, linear feature (Fence, hedge) 19% d. Bush, scrub 10% e. Open ground 7% f. Water, water's edge 7% 					
% of category	25%	50%	75%	80%	95%
Distance from LKP (Km)	0.34	0.95	1.89	2.51	5.47

Children 7-12 years

Children 7-12 years					
Characteristics:					
<ul style="list-style-type: none"> a. Have developing navigational skills. b. Are developing mental pictures of their environments, which are often inaccurate and highly distorted. c. Often become lost while attempting a short cut. d. Often become lost while 'role playing' or adventuring. e. Often become upset upon being lost and will act irrationally. f. May attempt to track run which can take them further from their LKP. g. Will act more rationally if with a friend or sibling. h. Will often attempt to self-help, not always successfully. 					
Tendencies:					
<ul style="list-style-type: none"> a. Will mostly stay on tracks or trails, or what they perceive to be tracks/trails. b. May seek out favourite places, hideouts etc, check with friends c. May seek out known landmarks, lookouts, high points, places they have been to in the past, lakes, ponds, areas where vegetation changes such as forest edges. 					
Strategies:					
<ul style="list-style-type: none"> a. Urgent response as this category can walk considerable distances. b. Confinement is a high priority. c. Reflex search teams to highest probability areas. d. Use dogs if available but do not delay search to wait. d. Passive techniques are not often successful. (Nicknames and favourite music may work). 					
Where located statistically:					
<ul style="list-style-type: none"> a. Habitation 25% b. Building/shelter 30% c. Road, Linear feature (Fence, hedge) 20% d. Forest/woods 12% e. Open ground 8% f. Water, water's edge 5% 					
% of category	25%	50%	75%	80%	95%
Distance from LKP (Km)	0.58	1.98	4.6	5.10	10.2

Youth 13-15

Youth 13-15					
Characteristics:					
<ul style="list-style-type: none"> a. Moderately developed navigational skills. b. Often become lost as part of a group engaged in exploring. c. Don't often travel far. d. Often respond to attractant techniques. e. Often seek familiar locations by direction sampling. f. Will act more responsibly as part of a group. g. Will often attempt to self-help. h. May panic if alone 					
Tendencies:					
<ul style="list-style-type: none"> a. Will mostly stay on tracks or trails. b. May seek out favourite places, hideouts etc, check with friends c. May seek out known landmarks, lookouts, high points, places they have been to in the past, lakes, ponds, areas where vegetation changes such as forest edges 					
Strategies:					
<ul style="list-style-type: none"> a. Urgent response b. Confinement is a low priority unless MP is alone c. Reflex search teams to highest probability areas. d. Use dogs if available but do not delay search to wait. e. Passive techniques are not often successful. 					
Where located statistically:					
<ul style="list-style-type: none"> a. Habitation 25% b. Waterway/Stream 17% c. Building/shelter 26% d. Forest/ woods 10% e. Road, Linear feature (Fence, hedge) 11% f. Forest edge or clearing 11% 					
% of category	25%	50%	75%	80%	95%
Distance from LKP (Km)	1.37	2.2	4.1	4.34	14.43

Appendices

Despondent/Suicidal

Despondent/Suicidal					
Characteristics:					
<ul style="list-style-type: none"> a. Don't often travel far, but intent to be alone. b. Often located a border of two types of terrain and/or vegetation boundary. c. May head for a scenic location or well-known beauty spot. d. Locations are often well known to MP, check with family/friends. e. Rarely located in dense underbrush or trees. f. Rarely respond to call and whistles and may hide. g. Very high fatality rate. h. Drugs and/or alcohol often involved. 					
Tendencies:					
<ul style="list-style-type: none"> a. Go to high points or scenic locations. b. Well known or favourite places. c. Terrain interfaces d. Group 1- merely seeking to get out of sight. e. Group 2- will seek out a specific location, significant to their life. f. Some in this category may travel further and adopt concealment methods. 					
Strategies:					
<ul style="list-style-type: none"> a. Investigation into background circumstances is important. b. Obtain a good subject profile from family, friends, GP (May be on depression meds) and social media. c. Urgent response. d. Thorough search of a small area. e. Confinement is a low priority. f. Passive techniques not successful. 					
Where located statistically:					
<ul style="list-style-type: none"> a. Habitation (Building or structure) 31% b. Water/water's edge 14% c. Forest/woods 24% d. No trace 13% e. Road/linear feature (Fence, hedge) 7% f. Forest edge/clearing (Near road/track) 11% 					
% of category	25%	50%	75%	80%	95%
Distance from LKP (Km)	0.41	1.05	2.29	2.43	18.14

A small percentage of all persons who go missing do so with the intent of committing suicide. The reasons for this are beyond the scope of this document but a wide and varied. The SMC should consider whether the MP is genuinely at risk of taking their own lives and what strategy should be used. Studies have shown that there is a strong link between depression and suicide. The two strongest indicators that a depressed person may contemplate suicide are:

- a) They have left a suicide note indicating their intentions of taking their own lives.
- b) They have recently talked about taking their own lives.

The SMC needs to obtain a detailed profile of the target person. There is often something in their background that is either the cause or trigger for them to contemplate suicide. Problems to look for are:

- Relationships
- Finances
- Sexual
- Employment
- Education
- Medical
- Mental health
- Addictions

If someone who is suffering depression has indicated an intention to take their own life, and has one or more of the above triggers present, there is a high probability that the person poses a high risk of taking their own life. The risk is normally low pre-teens and increases during puberty and adolescence, reaching a peak in the mid-twenties and remaining relatively constant until old age.

Religious conviction may be an indicator of suicide intent. Strongly Christian believers are less likely to commit suicide. Those with no religious beliefs have a high tendency towards suicide. In some religions, such as Judaism, Islamic, Hindu, Shinto, suicide is a valid way to depart earth.

If there is a suicide note, the contents may provide important information regarding where and how the person intends to suicide. It may provide specific information about a favourite or known location. It may also indicate that they will not be found which may point out that they will be in a secluded or difficult to reach location. The presence of a note does not automatically mean that the target has committed suicide as some people sue these notes for shock tactics to get attention or they change their minds and not follow through.

Gender is very important in determining whether suicide is a possibility. Men are three times more likely to take their own lives than women (ABS 2012). Men, 18-45, are the greatest at risk. Within the men group Aboriginal and Islander males are at a higher risk than average. Hanging is the most popular method (51%), with poisoning by drugs (15%) and poisoning by other methods such as car exhaust (16%) following. Jumping from high buildings, drowning, and firearms etc account for the remainder. Married men are less likely to commit suicide.

Once a person has reached the decision to commit suicide, they generally want to carry it out as soon as possible for the least amount of effort. Access to the means to do so should be investigated by the SMC as this may determine how and where it may take place.

There are many recorded instances where an adult has gone missing with their children. The killing of the children prior to suicide is not uncommon.

With the increased mobility of today's young people, it is often difficult to obtain sufficient details of a missing person because they have not established a close circle of friends. Social media sites such as 'Facebook', 'YouTube', and 'Instagram' may provide details about a missing person and any intentions that they may have.

Appendices

Psychological Illness

Psychological Illness					
Characteristics:					
<ul style="list-style-type: none"> a. May be evasive and run or hide. b. Often not respond to their name. c. Rarely travel purposely to a target. d. Medication or lack of it may be a problem. e. May be frightened of authority and of being found. f. Can be aggressive. g. Not actually lost in the normal sense. h. Difficult to predict behaviour. 					
Tendencies:					
<ul style="list-style-type: none"> a. Do not often penetrate forest or thick undergrowth b. Will seek shelter and seclusion c. May walk out when ready 					
Strategies:					
<ul style="list-style-type: none"> a. Check all buildings and places of shelter/seclusion. b. Check drains, streams and tracks. c. Obtain profile by talking to family, friends and medical experts. d. Dogs may be of use. e. Containment a priority. f. Re-search areas and tracks. g. On-going search of buildings as target may return to areas already searched. 					
Where located statistically:					
<ul style="list-style-type: none"> a. Road/Linear feature 29% b. Habitation 18% c. Building/shelter 22% d. Watercourse 14% e. No trace 6% f. Open ground 11% 					
% of category	25%	50%	75%	80%	95%
Distance from LKP (Km)	0.56	1.23	3.58	4.3	11.73

Developmental Problems

Developmental Problems					
Characteristics:					
<ul style="list-style-type: none"> a. Lack the concept of being lost. b. Cross between young children and Alzheimer's. c. Generally good survivability. d. Do not often respond to names or other signals. e. May also have a physical impairment. f. Rarely travel to a specific target but will seek shelter. g. Will often penetrate thick forest and undergrowth. h. Will often run away and avoid searchers. 					
Tendencies:					
<ul style="list-style-type: none"> a. Not route orientated. 					
Strategies:					
<ul style="list-style-type: none"> a. High urgency. b. Obtain profile from family. c. Dogs may assist. d. Detailed ground search. e. Check streams and drains. f. Re-searching areas is important. g. Check buildings etc ongoing. 					
Where located statistically:					
<ul style="list-style-type: none"> a. Building/shelter 39% b. Road, linear feature 28% c. Forest/Wood 22% d. No trace 3% e. Open ground 8% 					
% of category	25%	50%	75%	80%	95%
Distance from LKP (Km)	0.63	1.85	4.1	5.02	23.9

Appendices

Alzheimer's/Dementia

Alzheimer's/Dementia					
Characteristics:					
<ul style="list-style-type: none"> a. Poor short-term memory but may remember things that happened many years ago, such as address while a child. b. Impaired ability to rationalise surroundings. c. Often last seen in their home or a nursing home. d. May have a previous history of wandering. e. Other physical problems may exist (Limited mobility, poor sight or hearing). f. May be seeking a secluded location. g. Will not attract attention or respond to calls (Often no concept of being lost). h. Possible no concept of being lost. i. Will not often leave any clues apart from paradoxical undressing. j. Often succumbs to the environment (Hypothermia etc). k. 18% fatality rate if not located within first 24-hrs. l. Two types, walkers (Younger/fitter) and non-walkers (Elderly/medical issues). 					
Tendencies:					
<ul style="list-style-type: none"> a. Often located a short distance from a road or path. b. Will often attempt to travel to a place previously known to them (Even if this is an impossibility). c. Will be stopped by fences, hedges etc (Limited peripheral vision). d. Will tend to walk on the path of least resistance, downhill, and not often uphill. (Be aware: more physically capable, MP's may walk uphill or in a direct line regardless of terrain). e. Can be found in drains or streams due to then being downhill. f. May remove items of clothing, particularly in cold weather. 					
Strategies:					
<ul style="list-style-type: none"> a. High urgency, this category is very vulnerable to the environment. b. Early containment is essential. c. Use dogs or trackers but do not delay a search while waiting. d. Check all drains and low-lying areas. e. Check all fences, hedges and private yards in vicinity. f. Thorough search of the house, nursing home, and repeat every few hours. g. Search heavy bush. h. Search previous home locations. 					
Where located statistically:					
	a. Habitation/ structure	35%			
	b. Road (Rural and urban)	36%			
	c. Water/waterway	10%			
	d. Open ground (Fields etc)	10%			
	e. No trace	5%			
	f. Forest/Wood	4%			
% of category	25%	50%	75%	80%	95%
Elderly/non-walker Distance from LKP (Km)	0.19	0.51	1.4	1.5	3.9
Younger/walker Distance from LKP (Km)	0.49	1.28	2.65	3.2	14.0

Hikers/Walkers

Hikers/Walkers																					
Characteristics:																					
<ul style="list-style-type: none"> a. Often track orientated but become disoriented if they miss their track junctions or it is overgrown and not easily found. b. Tend to travel further than other categories. c. At times poorly prepared or experienced for type of walk. d. Will often attempt to self-help by track running or seeking a high spot. e. May follow paths of least resistance, such as streams and forest boundaries. f. May panic and be irrational. g. May look for shelter in poor weather, at nightfall or if injured. h. May seek higher ground to attempt a reorientation or re-section. i. May seek higher ground to gain mobile telephone reception. j. Will often make their situation worst by direction testing. k. Approximately 2% have died doing an activity or trying to self-help (A small % of these are never located). 																					
Tendencies:																					
<ul style="list-style-type: none"> a. Stay on tracks. b. Seek shelter. c. Seek high ground. 																					
Strategies:																					
<ul style="list-style-type: none"> a. Containment b. FAST and Reconnaissance teams to high probability areas. c. Track searches. d. Obtain profile and route details. e. Being clue aware. f. Be aware of the potentially large distances the MP could have walked. 																					
Where statistically located:																					
<table style="width: 100%; border-collapse: collapse;"> <tbody> <tr> <td style="width: 80%;">a. Road/track</td> <td style="width: 20%; text-align: right;">45%</td> </tr> <tr> <td>b. Water/watercourse/waterfall</td> <td style="text-align: right;">25%</td> </tr> <tr> <td>c. Building/shelter/hut</td> <td style="text-align: right;">4%</td> </tr> <tr> <td>d. Fence</td> <td style="text-align: right;">4%</td> </tr> <tr> <td>e. Forest edge</td> <td style="text-align: right;">3%</td> </tr> <tr> <td>f. Forest</td> <td style="text-align: right;">11%</td> </tr> <tr> <td>g. Open ground/farmland/agriculture</td> <td style="text-align: right;">1%</td> </tr> <tr> <td>h. Ground feature (Spot height, cliff etc)</td> <td style="text-align: right;">7%</td> </tr> </tbody> </table>						a. Road/track	45%	b. Water/watercourse/waterfall	25%	c. Building/shelter/hut	4%	d. Fence	4%	e. Forest edge	3%	f. Forest	11%	g. Open ground/farmland/agriculture	1%	h. Ground feature (Spot height, cliff etc)	7%
a. Road/track	45%																				
b. Water/watercourse/waterfall	25%																				
c. Building/shelter/hut	4%																				
d. Fence	4%																				
e. Forest edge	3%																				
f. Forest	11%																				
g. Open ground/farmland/agriculture	1%																				
h. Ground feature (Spot height, cliff etc)	7%																				
% of category	25%	50%	75%	80%	95%																
Distance from LKP (Km)	1.1	2.56	4.71	5.45	15.15																

Appendices

Hunters

Hunters				
Characteristics:				
<ul style="list-style-type: none"> a. Often game focused, which tends to contribute to their being lost. b. Will not often acknowledge that they are lost. c. Following targets often leads them to deadfall areas, boulder fields, underbrush or dense forest. d. Will go to great lengths to self-help. e. Will sometimes avoid searchers for fear of embarrassment. f. Often rely on GPS, radios and mobile phones. g. Usually mobile and responsive. h. Tend to travel at night and will follow linear features. i. Will take easy routes, ridge lines, cross country. j. Will make shelter and fire where possible. 				
Tendencies:				
<ul style="list-style-type: none"> a. Will attempt to self-help. b. Seek shelter. c. Seek high ground. 				
Strategies:				
<ul style="list-style-type: none"> a. Containment. b. FAST and Reconnaissance teams to high probability areas. c. Use of attraction techniques. d. Check historical finds. e. Air searches. f. Be aware of the potentially large distances the MP could have walked. 				
Where statistically located:				
<ul style="list-style-type: none"> a. Road 46% b. Forest 10% c. Building/shelter 5% d. Water/watercourse (with/without water) 17% e. Ridge lines 6% f. Open ground/grassland/unfenced areas 6% g. Re-entrants 10% 				
% of category	25%	50%	75%	100%
Distance from LKP (Km)	0.96	2.09	4.82	17.2

Climbers

Climbers																		
Characteristics:																		
<ul style="list-style-type: none"> a. Will often travel considerable distances to reach climb site. b. Generally, well equipped but beginners may attempt difficult climbs without adequate equipment. c. Often overdue because of over estimation of climbing ability (39%). d. May be caught out in bad weather (24%). e. Being lost is not common (17%). f. Being stuck because of weather is common. g. Trauma is often experienced (Rocks falling on them or others). h. Will often be lost going to and from the climb site. i. Some climbers are stranded by nightfall (12%) and cannot go up or down. 																		
Tendencies:																		
<ul style="list-style-type: none"> a. Will attempt to self-help. b. Seek shelter. c. Seek high ground. 																		
Strategies:																		
<ul style="list-style-type: none"> a. Containment. b. FAST and Reconnaissance teams to high probability areas and tracks. c. Use of attraction techniques. d. Snow/Avalanche search if necessary. e. Thorough search of 25% zone. f. Climbing location is the immediate area. g. Check other climbs and routes in area. 																		
Where statistically located:																		
<table style="width: 100%; border-collapse: collapse;"> <tr> <td style="width: 80%;">a. Scree slope</td> <td style="width: 20%; text-align: right;">24%</td> </tr> <tr> <td>b. Water/watercourse/waterfall</td> <td style="text-align: right;">25%</td> </tr> <tr> <td>c. Re-entrant/rocks</td> <td style="text-align: right;">30%</td> </tr> <tr> <td>d. Ridgelines</td> <td style="text-align: right;">10%</td> </tr> <tr> <td>e. Open ground</td> <td style="text-align: right;">6%</td> </tr> <tr> <td>f. Forest/forest edge</td> <td style="text-align: right;">9%</td> </tr> <tr> <td>g. Road/track</td> <td style="text-align: right;">2%</td> </tr> </table>					a. Scree slope	24%	b. Water/watercourse/waterfall	25%	c. Re-entrant/rocks	30%	d. Ridgelines	10%	e. Open ground	6%	f. Forest/forest edge	9%	g. Road/track	2%
a. Scree slope	24%																	
b. Water/watercourse/waterfall	25%																	
c. Re-entrant/rocks	30%																	
d. Ridgelines	10%																	
e. Open ground	6%																	
f. Forest/forest edge	9%																	
g. Road/track	2%																	
% of category	25%	50%	75%	100%														
Day climber Distance from LKP (Km)	0.0	0.3	0.8	1.8														
Mountaineer Distance from LKP (Km)	0.1	1.0	3.0	10.5														

Appendices

Prospectors

Prospectors				
Characteristics:				
<ul style="list-style-type: none"> a. Often do not tell family and/or friends of exact location. b. Often prospect alone, even if with a group. c. Often become distracted by detection equipment, ore formations on ground. d. Often well prepared for prospecting. e. Not often well prepared for extended survival, limited water/food carried. f. Not often equipped with GPS, compass, map. g. Often rely on memory or maps kept on their person. h. Not always fit. 				
Tendencies:				
<ul style="list-style-type: none"> a. Are not track orientated. b. Tend to take limited notice of surroundings outside of immediate area of interest. c. Tend to prospect out and back from a central location. d. May travel larger distances following a possible ore seam, ground formation. e. May lose track of time. f. May attempt to self-help. g. May seek shade, water where possible. 				
Strategies:				
<ul style="list-style-type: none"> a. Identification of central location, camp or LKP. b. Obtain information on where ore has been located previously in area. c. Check all abandoned/old/current mine shafts. d. Thorough search of a small area around identified central location. e. Confinement is a low priority. f. Passive techniques should be attempted. g. Aerial searching may provide clues and aid in self-help. 				
Where located statistically:				
<ul style="list-style-type: none"> a. Open country (Tracks/desert/lightly wooded areas) 32% b. Closed country (Thick scrub/woodland) 32% c. Watercourses (Wet or dry) 18% d. No trace 12% e. Mine shafts (Abandoned/used) 6% 				
% of category	25%	50%	75%	95%
Distance from LKP (Km)	0.75	1.7	3.5	6.5

ADD, ADHD, Asperger's, Autism

ADD, ADHD, Asperger's, Autism				
Characteristics:				
<ul style="list-style-type: none"> a. Tend to travel alone. b. Not track or trail orientated. c. Have an affinity for water. d. Have difficulty concentrating. e. Have limited social skills. f. Often don't recognise/understand they are lost. g. Limited survival skills but survivability is increased due to rapid response. h. Rarely respond to call and whistles and may hide. 				
Tendencies:				
<ul style="list-style-type: none"> a. Appear to wander aimlessly but may have a destination or plan in mind. b. Will often head to water (Pools, creeks, canals, drains, golf course water hazards). c. Will possibly be avoiding searchers. d. Limited fear of the unknown. e. Often unresponsive to passive search techniques. f. May be attracted to vessels, vehicles, trains or aircraft. 				
Strategies:				
<ul style="list-style-type: none"> a. Investigation of characteristics of MP is important (May think they are playing). b. Urgent response required. c. Check all water hazards. d. Establish barriers and/or confinement. e. In an urban environment a minute systematic search is required. f. Utilise media. g. Passive techniques not successful (Nick names, favourite music/toys may be useful). 				
Where located statistically:				
<ul style="list-style-type: none"> a. Habitation (Buildings and yards) 35% b. Water/watercourses 35% c. Forest/woods/paddocks/fields 20% d. Road/track/path 8% 				
% of category	25%	50%	75%	95%
Distance from LKP (Km)	0.25	0.6	1.2	6.0

Appendices

First Nation People

First Nation People					
Characteristics:					
<ul style="list-style-type: none"> a. Often travel further than other LPB categories. b. Often have a good understanding of their locale. c. May head for a location known to them or of significance (Spiritual or totem). d. Locations may or not be known by other family and totem members. e. Generally, travel to an area with survival resources (Water). f. Rarely respond to call and whistles and may hide. g. May be involved in rites such as singing/boning. h. Drugs and/or alcohol can be involved. i. May not want to be found (Particularly by searchers). 					
Tendencies:					
<ul style="list-style-type: none"> a. They do not wander aimlessly, there is often a purpose. b. Well known or spiritual places. c. Can travel significant distance compared to people of similar age/build. d. May be going to die. e. May be undertaking a ritual activity and will return upon completion. 					
Strategies:					
<ul style="list-style-type: none"> a. Investigation into circumstances is important. b. Cultural understanding is vital, particularly of rituals, totem aspects and seasonal activities. c. Obtain a good subject profile from family, friends, and social media. d. Urgent response, but MP generally has survival skills in their own environment. e. Will require searching further than anticipated. f. Confinement is a low priority. g. Passive techniques not successful. 					
Where statistically located:					
<ul style="list-style-type: none"> a. Open wilderness (Desert/plains) 28% b. Water holes (Known/secret) 24% c. Forest/vegetation 18% d. Sacred locations 18% e. No trace 12% 					
% of category	25%	50%	75%	80%	95%
Distance from LKP (Km)	7.0	12.0	19.0	23.0	43.0

Appendix E-6 Land Search Planning Tables

Land Search Planning Tables

Searcher Speed

1. Select speed of Searcher:

Search member speed kph	
5 kph	Consistent walking pace, undulating ground, light vegetation
4 kph	Steady walking pace partly restrained by vegetation and topography
3 kph	Walking pace restrained by vegetation and topography
2 kph	Slow walking pace considerably restrained by vegetation and topography
1 kph	Dead slow walk severely hampered by vegetation and topography

Searcher Spacing

2. Select search spacing (in kph):

Searcher spacing	
50 m (0.05 Km)	Open grassland or pasture
40 m (0.04 Km)	Open grassland interspersed with light shrubbery
30 m (0.03 Km)	Open country with low lying scrub and light undergrowth
20 m (0.02 Km)	Heavier scrub, medium undergrowth
15 m (0.015 Km)	Heavy scrub, undergrowth to shoulder height
10 m (0.01 Km)	Heavy shrub, dense undergrowth
5 m (0.005 Km)	Ground visual between searchers
2.5 m (0.0025 Km)	Dense undergrowth, ground visual

ATNPS Calculations

3. Then calculate Area (A), Time (T), Number of searchers (N), Search Pace (P) or Spacing (S)

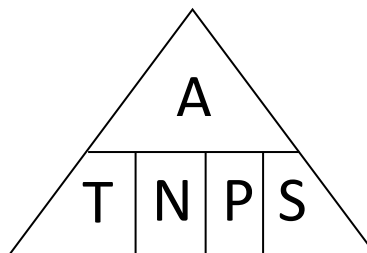
$$A = T \times N \times P \times S$$

$$T = A \div (N \times P \times S)$$

$$N = A \div (T \times P \times S)$$

$$P = A \div (T \times N \times S)$$

$$S = A \div (T \times N \times P)$$



Example: What area could I search with 20 personnel, at 5 m spacing, walking at 2 kph in 3 hours?

$$A = T \times N \times P \times S = 3 \text{ hrs} \times 20 \times 2 \text{ kph} \times 0.005 \text{ Km} = 0.6 \text{ Km}^2$$

$$T = A \div (N \times P \times S) = 0.6 \text{ Km}^2 \div (20 \times 2 \text{ kph} \times 0.005 \text{ Km}) = 3 \text{ hrs}$$

$$N = A \div (T \times P \times S) = 0.6 \text{ Km}^2 \div (3 \text{ hrs} \times 2 \text{ kph} \times 0.005 \text{ Km}) = 20 \text{ searchers}$$

$$P = A \div (T \times N \times S) = 0.6 \text{ Km}^2 \div (3 \text{ hrs} \times 20 \times 0.005 \text{ Km}) = 2 \text{ kph}$$

$$S = A \div (T \times N \times P) = 0.6 \text{ Km}^2 \div (3 \text{ hrs} \times 20 \times 2 \text{ kph}) = 0.005 \text{ Km} = 5 \text{ m}$$

Land Search Area Quick Reference

Example: At 1 kph and 5m spacing = 0.005 Km²/searcher/hour

Speed	Area covered in Km ² at track spacing of:							
Kph	2.5 m	5 m	10 m	15 m	20 m	30 m	40 m	50 m
1	0.0025	0.005	0.01	0.015	0.02	0.03	0.04	0.05
2	0.005	0.01	0.02	0.03	0.04	0.06	0.08	0.1
3	0.0075	0.015	0.03	0.045	0.06	0.09	0.12	0.15
4	0.01	0.02	0.04	0.06	0.08	0.12	0.16	0.2
5	0.0125	0.025	0.05	0.075	0.1	0.15	0.2	0.25

Land Air Search Planning Table

Uncorrected Sweep width (Wu) for visual search OVER LAND. 'Wu' is in kilometres for this table (Pilots will be able to convert back to NM if necessary).

Search Height (ft)		Human					Vehicle				
		0	500	1000	1500	2000	0	500	1000	1500	2000
Visibility	2 Km	-	0.75	0.75	-	-	0.93	1.11	1.3	1.11	0.93
	5 Km	-	0.75	0.75	-	-	1.3	1.66	2.78	3.15	3.7
	10 Km	-	0.75	0.75	-	-	1.66	2.40	2.78	3.15	3.7
	15 Km	-	0.93	0.75	-	-	1.66	2.40	2.78	3.15	3.7
	20 Km	0.75	1.11	0.93	0.75	0.75	1.66	2.40	2.78	3.15	3.7
	25 Km	0.75	1.11	0.93	0.75	0.75	1.66	2.40	2.78	3.15	3.7
	30 Km	0.75	1.11	0.93	0.75	0.75	1.66	2.40	2.78	3.15	3.7
	35 Km	0.75	1.11	0.93	0.75	0.75	1.66	2.40	2.78	3.15	3.7
	40 Km	0.75	1.11	0.93	0.75	0.75	1.66	2.40	2.78	3.15	3.7
	55 Km	0.75	1.11	0.93	0.75	0.75	1.66	2.40	2.78	3.15	3.7
	75 Km	0.75	1.11	0.93	0.75	0.75	1.66	2.40	2.78	3.15	3.7
90 Km	0.75	1.11	0.93	0.75	0.75	1.66	2.40	2.78	3.15	3.7	

Vegetation Correction Factor (Ve)

Vegetation	Human	Vehicle
Less than 15% (Open areas or scattered shrub)	0.8	1.0
15% to 60% (Medium scrub or forest)	0.5	0.7
60% to 85% (Dense scrub or forest)	0.3	0.4
Over 85% (Rain Forest)	0.1	0.1

Cloud cover correction factor

Shadows cast by scattered and broken clouds are a distracting influence on observers. Compensate for this by rounding down the corrected sweep width when the sky is partially obscured.

Example: Target is a missing person, Vis = 20 Km, Search height is 1000 ft, vegetation is 15-60%

Corrected Sweep Width(W) = $W_u \times V_e$

$W = 0.93 \times 0.5$

$W = 0.465$ Km (Round down to 0.45 Km or 0.4 Km for partly obscured sky)

Most Common Applications

Land searching for:

1. Missing person open terrain (Farming country, desert areas) = SEARCH HEIGHT 500 ft TRACK SPACING 500 m
2. Missing vehicle in relatively open terrain = SEARCH HEIGHT 2000 ft TRACK SPACING 3 Km

Appendix E-7 Additions to Naismith's Rule

Naismith's Land Speed / Time Calculations

Land Speed/Time Calculations		
Terrain	Speed	Per minute equivalent
Road	5 kph	100 m each 1.2 minutes
Track	4 kph	100 m each 1.5 minutes
Trail	3 kph	100 m each 2.0 minutes
Off Track	2 kph	100 m each 3.0 minutes
Scrub	1 kph	100 m each 6.0 minutes
Ascending: Add 12 minutes per 100 m for overall time taken (Equivalent to 1 hr every 500 m ascent)		
Descending: Add 6 minutes per 100 m for overall time taken (Equivalent to 1 hr every 1000 m descent)		
Fatigue	2 hours add 10 minutes 3 hours add 25 minutes 4 hours add 40 minutes 5 hours add 60 minutes	

Tranter's Corrections

In the past three decades much work has been devoted to modifying Naismith's rule to meet modern conditions. One such system is to utilise Naismith's Rule to calculate a time then apply Tranter's Corrections when working out a possible search area.

Tranter's Corrections																
Time taken to climb 300 m over 800 m																
Individual fitness in minutes	Times taken in hours estimated using Naismith's Rule															
	2	3	4	5	6	7	8	9	10	12	14	16	18	20	22	24
15 (very fit)	1	1.5	2	2.25	3.5	4.5	5.5	6.8	7.8	10	13	14.5	17	19.5	22	24
20	1.25	2.25	3.25	4.5	5.5	6.5	7.75	8.8	10	13	15	17.5	20	23		
25	1.5	3	4.25	5.5	7	8.5	10	12	13	15	18					
30	2	3.5	5	6.75	8.5	10.5	12.5	15								
40	2.75	4.25	5.75	7.5	9.5	11.5										
50 (unfit)	3.25	4.75	6.5	8.5												
Too much to be attempted																
Limit Line																

The fitness level in the first column is the time it takes to climb 300 m over 800 m and can be determined through series of trials.

The following corrections to Tranter's Corrections should also be made for the following conditions:

20 kg load being carried	Drop one fitness level
Conditions underfoot	Drop one level or more according to conditions
Conditions overhead	Drop one level for journey at night or if wind is blowing against you

Appendix E-8 Land SAR Probability of Detection (Land)

Caveat

POD for land is a new concept within Australia. It is more common in Canada, UK and New Zealand. The theory behind this is based on the Marine POD.

Area to be Search (AS)

Area to be Search (AS) is the actual area, in square kilometres, to be searched by a particular team and where possible should be equal to or less than 1 Km² per search team task.

Area swept (AW)

Area swept is the mathematical area that was able to be searched (Swept) by the search team. The spacing of searchers is a function of detection capability. The more difficult the target is to detect, the closer the searchers should be. Decreasing the spacing increases the POD, but at the expense of reducing the area able to be searched in a given time. The optimum spacing is one which permits the maximum expectation of target detection in the available time or is consistent with the economic employment of search units. Whenever possible the Area Swept (AW) used should be equal to the Area of Search (AS).

Coverage Factor (C)

The coverage for a land search is a relationship between Area Swept (AW) and the Area to be Searched (AS). The relationship is termed Coverage Factor.

$$\text{Coverage Factor (C)} = \frac{\text{Area Swept (W)}}{\text{Area of Search (S)}}$$

The relationship between Area Swept and the Area to be Searched determines the Probability of Detection (POD). The area swept is the actual area that was covered by the searchers (Calculated using ATNPS or on area determined at team debrief), while the area to be searched is the area given to that team to search. Higher coverage factors indicate that a search has been thorough and offer a higher probability of target detection; however, the higher POD is not proportional to the extra search effort required.

Where possible the SMC should be aiming for a coverage factor of 1, that is, the area given to the team is capable of being searched in the time frames available. There will be many occasions when terrain, time limitations, largeness of the search area, or shortage of searchers will prevent this. These situations will need an alternative approach that balances the factors of available search hours, size of area and C.

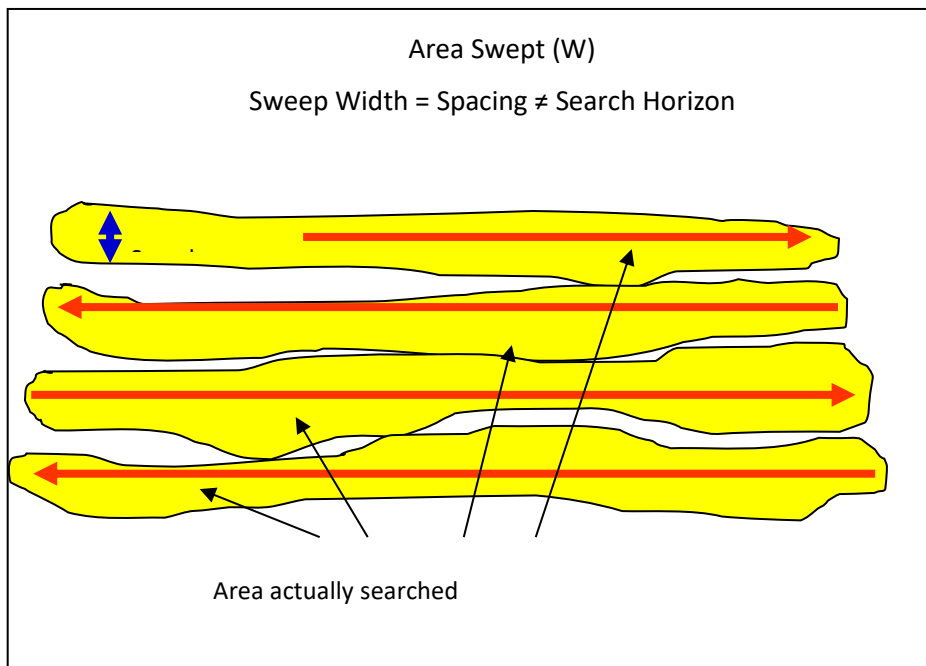


Figure E-8:1: Area Swept

Probability of Detection (POD)

Probability of detection (POD) is the statistical measure of search detection performance. It is a function of:

- a) Number of searchers
- b) Size of area to be searched
- c) Speed of searchers
- d) Spacing of searchers
- e) Fatigue
- f) Responsiveness or not of the target
- g) Detectability of target
- h) Daylight or darkness
- i) Vegetation and terrain
- j) Weather

These factors ultimately equate to the ratio of the Area Swept and the Area to be Searched. It is also conditional, meaning that search planners assume the search target is in the search area. A definite POD exists for each scan made by an individual searcher. The probability that a discovery will be made in a single search scan is called the instantaneous POD. The instantaneous POD, repeated by successive scans as the searcher moves along the track, develops the probability pattern of a given search.

The POD is not uniform over the swept area. In general, it is highest near the searcher and decreases with distance from the searcher. Although POD is based upon each searcher the end calculation will pertain to the entire search team. POD is a function of the coverage factor (C), which itself is derived from the relationship of Area Swept and the Area to be Searched. Searching areas for second or more times will have the effect of increasing the cumulative POD. The application of this concept results in a progressive increase in the POD of a target in the most likely sector of the search area by repeatedly searching the original area within progressively larger areas, a part of each overlaying the original.

Utilising the land POD v Coverage Table below it can be seen that, when compared with marine SAR, there is only one search line which is to be used for all searches. A Coverage Factor (C) of 1.0 will give a POD of

approximately 63%, whereas a Coverage Factor (C) of 0.5 will give a POD of approximately 40%. Some confusion may exist over this graph. It is generally assumed that if the area swept and the area to be searched is the same, the Coverage Factor (C) will be 1 or 100%. This is not the case as land search is in a three-dimensional environment and it is not possible for any search team to search every location within a land search area, hence the 63% POD (Searchers may be looking left instead of right, down instead of up). This is because there are always going to be gaps where searchers search, refer to the Area Swept diagram on the previous page. The yellow areas are those searched while the white areas in between are those that were missed. In reality, a searcher has searched approximately 63% of the area assigned to them. The following example will make this clearer:

There are 2 hours to search an area of 1 Km². There is a team of 10 personnel who will walk at 2 kph with a space of 20 metres between searchers. (20 m = 0.02 Km). All measurements need to be in the same terms, either metres or kilometres.

Area Swept

$$\text{Area Swept (A)} = \text{Time (T)} \times \text{Number (N)} \times \text{Pacing (P)} \times \text{Spacing (S)}$$

i.e. $A = TNPS$

$$A = 2 \text{ hrs} \times 10 \text{ searchers} \times 2 \text{ kph} \times 0.02 \text{ Km}$$

$$A = 0.8 \text{ Km}^2$$

Coverage:

$$C = \text{Area Swept} \div \text{Area of search}$$

$$C = 0.8 \text{ Km}^2 \div 1.0 \text{ Km}^2$$

$$C = 0.8$$

This figure can now be used in a Land SAR POD Table as shown below. Using the 0.8 on the bottom line we arrive at a coverage figure of 56%. This is because land search is always a compromise between spacing and the ability to see objects on the ground. It is almost impossible to achieve a 100% POD for any land SAR.

A coverage factor of less than 0.5 may be unsatisfactory.

POD vs. Coverage

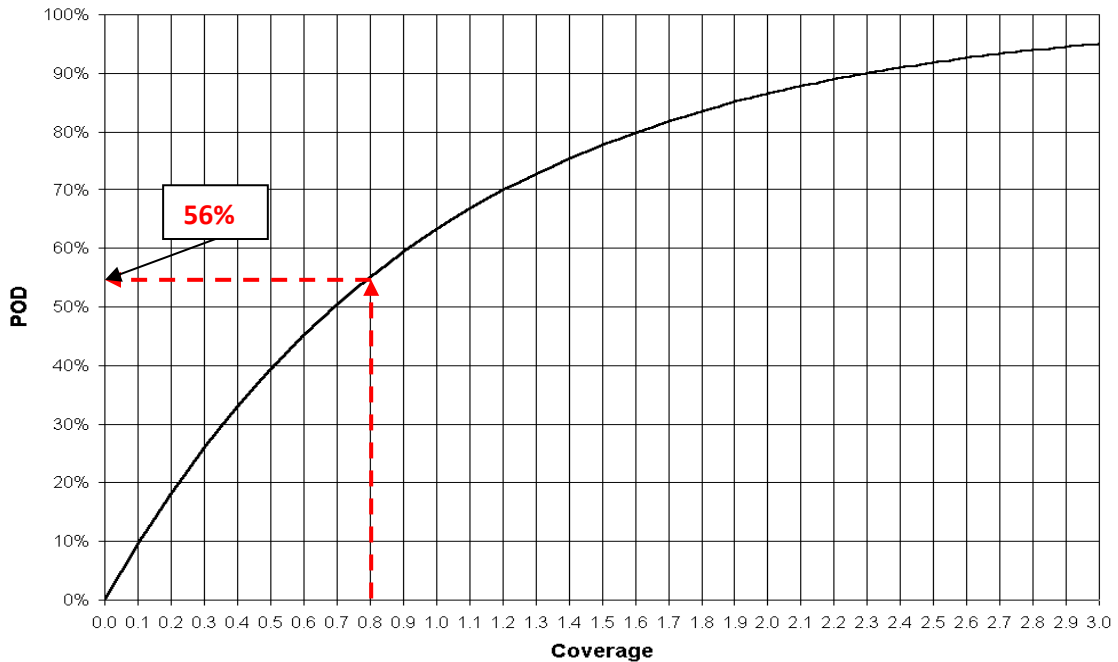


Figure E-8:2: Land SAR POD Table

Technically it is not possible to search an area greater than that assigned so how do you get a Coverage Factor (C) greater than 1? If you have a 2 Km² area to search and have the following: 2 hours, 10 searchers walking at 2 kph and spacing of 50 m.

Using the ATNPS formula this will give a Coverage Factor (C) of 1

$$A = 2 \text{ hrs} \times 10 \text{ searchers} \times 2 \text{ kph} \times 0.05 \text{ Km spacing} = 2 \text{ Km}^2$$

$$C = 2 \text{ Km}^2 \div 2 \text{ Km}^2 = 1 = 63\%$$

If I increase the number of searchers by 5, but utilise them in the same area:

$$A = 2 \text{ hrs} \times 15 \text{ searchers} \times 2 \text{ kph} \times 0.05 \text{ Km spacing} = 3 \text{ Km}^2$$

$$C = 3 \text{ Km}^2 \div 2 \text{ Km}^2 = 1.5 = 78\%$$

Although the formula gives a larger area searched, in reality we have searched the original area to a greater extent, with the five extra searchers. We can increase either the time allowed to search an area, the number of searchers, search pacing or their distance apart to increase the C. (Twice the speed will double the area searched, or in our case, searching the same area twice, going up and back. The same will apply if the spacing is increased.)

The Land Cumulative POD Table (At end of this appendix) shows that two searches with an initial C of 0.5 (39% POD) will combine to produce a total POD of 64%, which is equivalent to conducting one search with a C of 1.0. It can also be seen that as more searches are conducted within that particular search area the POD slowly increases, as would be expected.

Two searches in a particular area can be worked directly off the Land Cumulative POD table with the first search POD being entered on the left and the second across the top. For a third search the cumulative POD for the first two searches is entered into the left side of the table and the new search POD across the top.

Example:

Search 1 has a POD of 40%, search 2 has a POD of 50%. A cumulative POD for these two searches is 70%. Search 3 has a POD of 40%.

Using the 70% from the first two searches on the left of the table (Figure E-8:3) and the new POD of 40% across the top a three-search cumulative POD is 82%. This process is continued for each subsequent search.

From the foregoing, it is apparent that for lengthy and repeated searches when searcher numbers are limited, a coverage factor of 0.5 offers a reasonable coverage of an expanded area resulting, over time, in a good POD. Search of areas at a coverage factor less than 0.5 is not recommended. Statistically, the target is more likely to be nearer the last known position than in the extremities of the search area.

Application of the expanded search concept ensures that the greatest search effort is concentrated over the most probable position of the target where the POD is highest. Clearly, the expanding search procedure is best suited to situations where the approximate position or, at least, the planned route of the target is known.

The projected value of the POD may be used by a SMC in determining the area of search. Use of POD may also be conveniently made in describing the results of a search, or part of a search, to interested persons not familiar with search planning techniques. Should the target not be located within the entire search area, the SMC must decide whether to continue searching it, recalculate the probability area using alternative data, or recommend the suspension of search effort.

Cumulative POD Table																				
	POD this search																			
	%	5	10	15	20	25	30	35	40	45	50	55	60	65	70	75	80	85	90	95
Previous POD	5	10	15	19	24	29	34	38	43	48	53	57	62	67	72	76	81	86	91	95
	10	15	19	24	28	33	37	42	46	51	55	60	64	69	73	78	82	87	91	96
	15	19	24	28	32	36	41	45	49	53	58	62	66	70	75	79	83	87	92	96
	20	24	28	32	36	40	44	48	52	56	60	64	68	72	76	80	84	88	92	96
	25	29	33	36	40	44	48	51	55	59	63	66	70	74	78	81	85	89	93	96
	30	34	37	41	44	48	51	55	58	62	65	69	72	76	79	83	86	90	93	97
	35	38	42	45	48	51	55	58	61	64	68	71	74	77	81	84	87	90	94	97
	40	43	46	49	52	55	58	61	64	67	70	73	76	79	83	85	88	91	94	97
	45	48	51	53	56	59	62	64	67	70	73	75	78	81	84	86	89	92	95	97
	50	53	55	58	60	63	65	68	70	73	75	78	80	83	85	88	90	93	95	98
	55	57	60	62	64	66	69	71	73	75	78	80	82	84	87	89	91	93	96	98
	60	62	64	66	68	70	72	74	76	78	80	82	84	86	88	90	92	94	96	98
	65	67	69	70	72	74	76	77	79	81	83	84	86	88	90	91	93	95	97	98
	70	72	73	75	76	78	79	81	82	84	85	87	88	90	91	93	94	96	97	99
	75	76	78	79	80	81	83	84	85	86	88	89	90	91	93	94	95	96	98	99
	80	81	82	83	84	85	86	87	88	89	90	91	92	93	94	95	96	97	98	99
	85	86	87	87	88	89	90	90	91	92	93	93	94	95	96	96	97	98	99	99
90	91	91	92	92	93	93	94	94	95	95	96	96	97	97	98	98	99	99	99	
95	96	96	96	96	96	97	97	97	97	98	98	98	98	99	99	99	99	99	99	

Figure E-8:3: Cumulative POD for Land Search

Appendix E-9 Mattson Consensus

Overview

The Mattson Consensus is used when two or more search areas have an equal chance of being the area of highest probability. The search areas are identified across the top of the form (Areas A, B, C etc.) as is the Rest of the World (ROW) as it may be the case that the MP is outside the identified search areas. The names of the senior or more expert members of the SAR Team are listed on the left side (Name 1, Name 2 etc.), remembering that there should be at least five members.

Each member then independently gives a weighting score to each search area and the ROW. Generally, the higher number weighting, the greater belief by the member that the target will be in that search area. There is no need for the weightings to add up to one hundred as this can cause skewing to ensure a fit.

The columns and rows are totalled and recorded in the appropriate places. The Consensus Weight is the total in each column at (a) divided by the total at (c). The Consensus Weight (d) is then multiplied by 100 to obtain the search area percentage (e). The search area with the highest percentage is considered, by consensus, to be the area of highest probability and would be searched first, followed by search area 2 and so on.

Mattson Consensus Worksheet

Mattson Consensus Worksheet							
Search areas	Area A	Area B	Area C	Area D	Area E	ROW	Subtotal Across (b)
Name 1	10	12	30	10	5	2	69
Name 2	15	21	50	2	2	0	90
Name 3	10	20	30	10	10	10	90
Name 4	5	30	40	5	10	5	95
Name 5	10	20	20	10	10	10	80
Subtotal Down (a)	50	103	170	37	37	27	= sum of (a)'s or (b)'s 424 (c)
Consensus Weight (d) => (a) ÷ (c) = Weight (d)	50/424 = 0.12	103/424 = 0.24	170/424 = 0.40	37/424 = 0.087	37/424 = 0.087	27/424 = 0.06	
Percentage (e) => (d) x 100 = (e)	12%	24%	40%	9%	9%	6%	100%

Figure E-8:4: Cumulative POD for Land Search

Appendix E-10 Land Search Organisation Chart Example

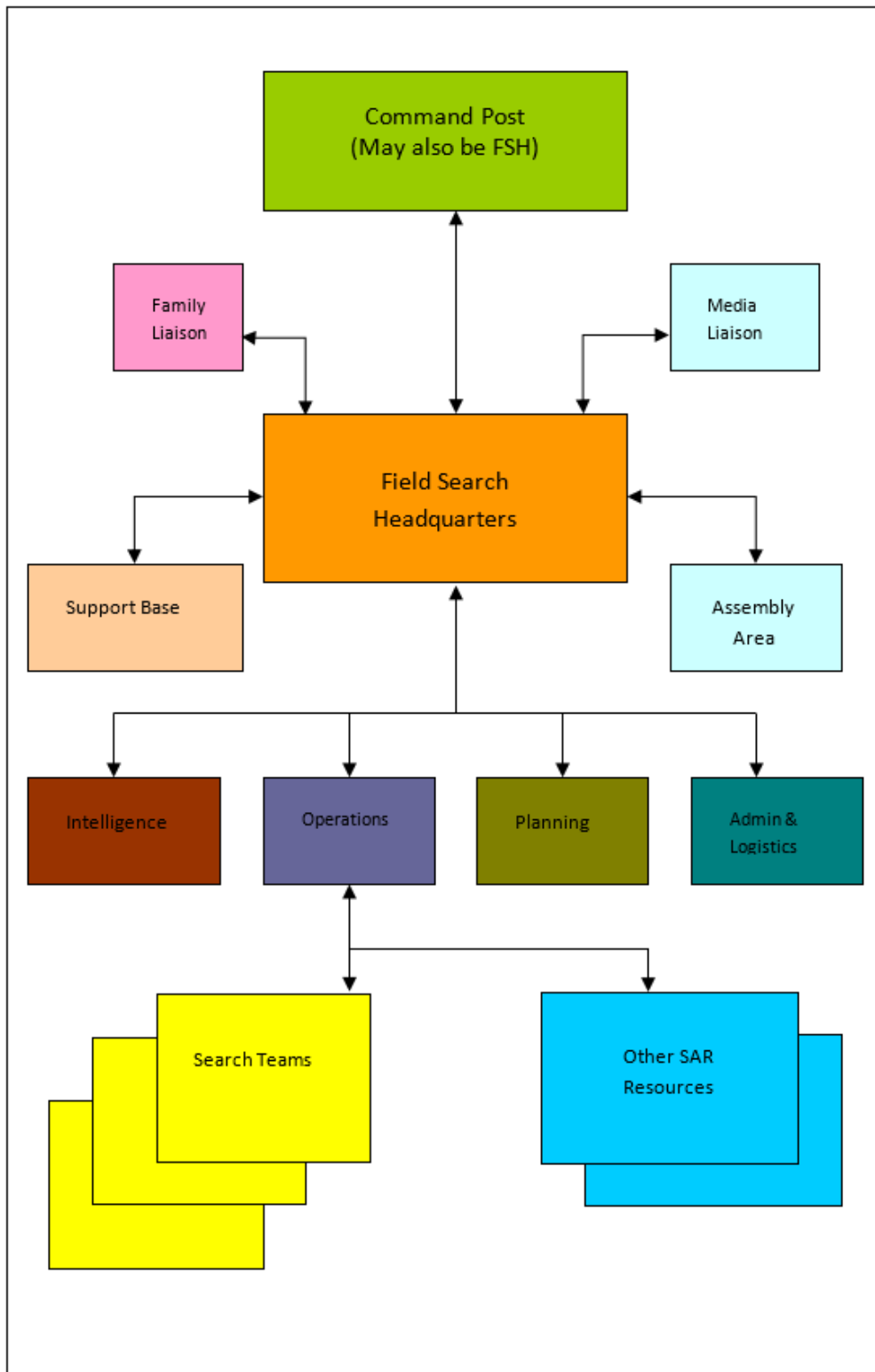


Figure E-10:1: Land Search Organisation Chart

Appendix E-11 Field Search Headquarters Layout Example

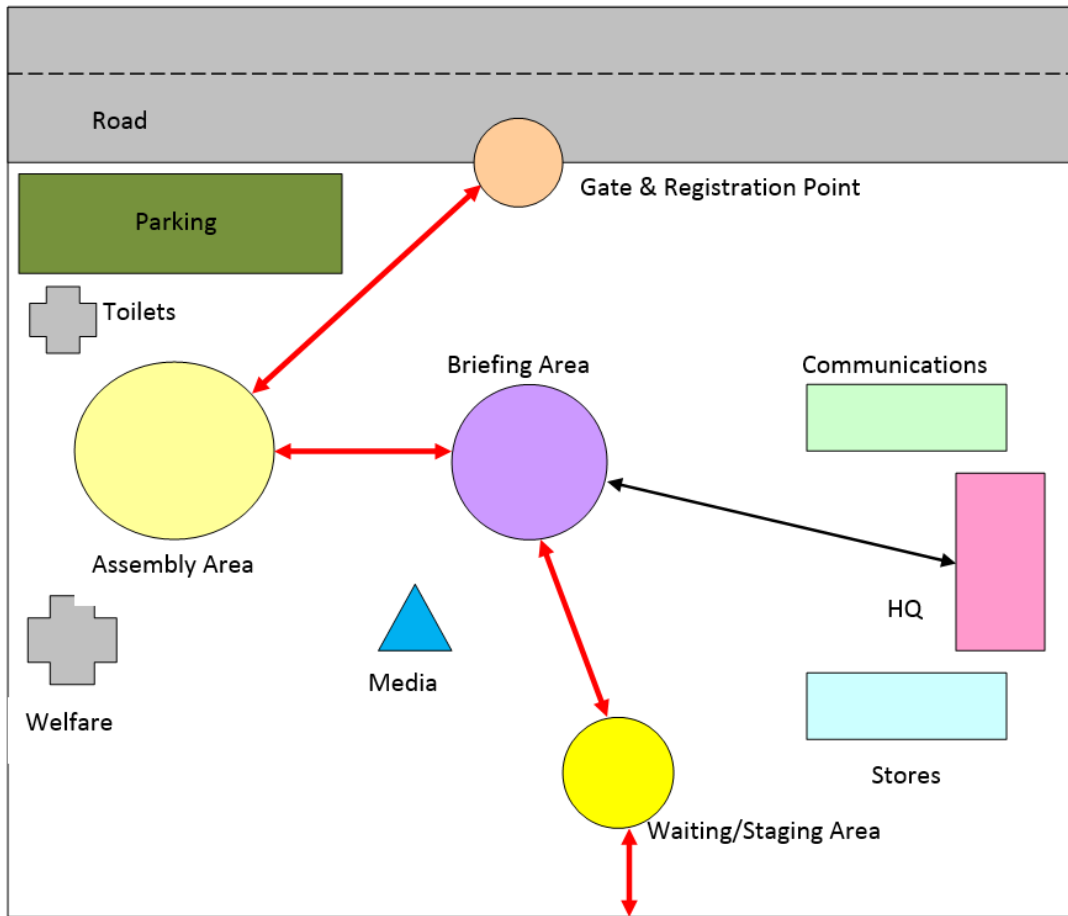


Figure E-11:1: Headquarters Layout

Appendix E-12 Search Communications Network Example

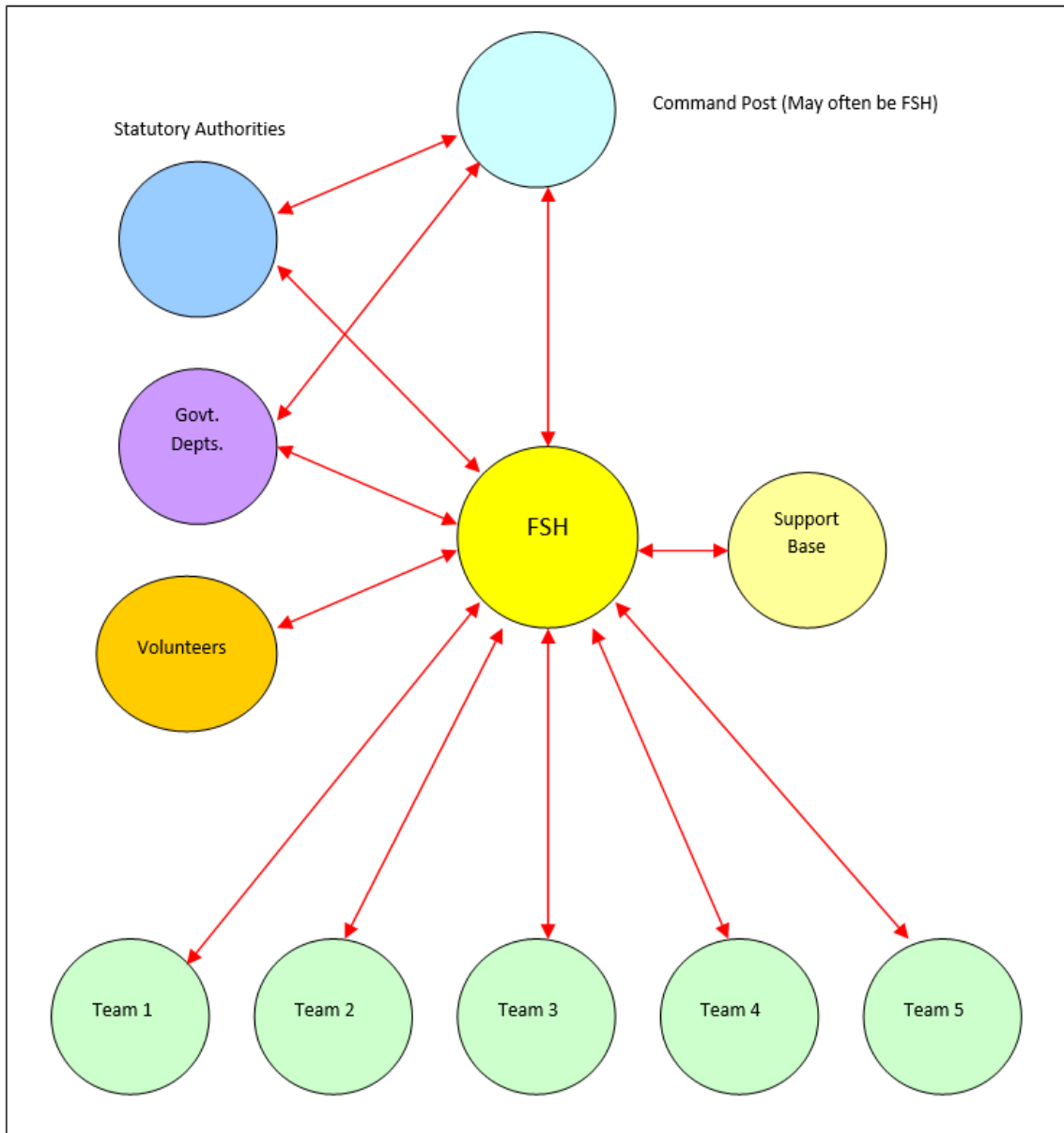


Figure E-12:1 Search Communications Network

Appendix E-13 Clue Recognition

A clue is a fact, an object, information or some type of evidence that helps to solve a mystery or problem. The purpose of seeking clues (gathering all the facts and information) is to assist in the reasoning of a problem and its ultimate solution. In SAR this assists in the ongoing development and assessment of the SAR Plan.

General Principles:

The following principles apply:

- a) Clue seeking is an ongoing process that starts with the planning, continues throughout a mission until the debrief concludes.
- b) Clue seeking is a skill and must be practiced to develop a sense of what is the minimum information to work with.
- c) Avoid forming opinions and then gathering information to support that opinion.
- d) Don't immediately form an opinion about the value of a clue.
- e) Gather information from everyone, as no one person can adequately gather all the facts.
- f) Assemble a complete profile of the missing target and the situation, and let it offer direction.

Tracking Skills

The ability for searchers to recognise signs that are not obvious clues within their search area can dramatically reduce the duration of the search. These signs may be quite obvious to some searchers but may go unseen by others. Developing skills in reading signs of activity within the landscape can greatly benefit the searcher and enhance their observation skills.

Trail signs

Once the size and shape of footprints is determined, another factor that can aid your search is terrain. Look at the ground. If no footprints are apparent, look for freshly overturned stones (darker on top than the others, maybe even moist looking).

Look for broken twigs and tree branches. They will usually break forward as a person pushes through unless deliberately snapped back to lay a false trail. Fresh breaks will show up as unweathered timber, differently coloured to the rest of the tree. The underside of the leaves will be duller or more brightly coloured as well, depending on the species.

Through thick bush a lighter area can often be apparent when scrub is pushed aside, much like long grass that is flattened in the direction of travel.

When footprints are found, use the weather that has occurred since the person went missing to estimate the time since the print was left. The amount of dryness of the print can determine an approximate time the person passed that way. Other factors that should be considered are described below:

- a) If the weather was previously damp and windy, a predominantly dry print will indicate it has been in the open to the wind longer and has had time to dry out.
- b) If wetter weather had occurred but no real rain has fallen recently, the same print may have been there for a lesser period. The heel will be the last area to dry. If the heel depression is dry, the person travelled that area a longer time ago than if the print is partially damp.
- c) If heavy rain has fallen, most prints will appear to wash back into the soil and be little more than a depression. Newer laid prints will be more defined.
- d) If it is currently drizzling/raining, fresh footprints may disturb the ground surface layer and produce a dry under surface.

Scuff marks on the ground, which also kicks up rocks, scuff marks on rocks where someone has climbed, broken pieces of rotted wood are all indicators of someone, or something, having travelled that way. A lost

person may sit down and rest regularly, so look for heel and seat marks where they may have sat down. Think what you would do in their position and identify likely locations for rest.

Flattened ground beneath trees or amongst the undergrowth can indicate a sleeping place, either of the missing person or fauna. A check for animal cast may indicate occupation by animals. A thorough search of the area might show footprints where a person has used an animal lair. Personal items or human faeces may also be detected in these areas.

Keep an eye out for signals that have been made by the missing person. These include rock piles (sometimes a message may have been left within the layers of rocks), arrows or other marks left on the ground to indicate their direction of travel, flashes from mirrors, or items of clothing.

When tracking, work as a pair if possible. Work to either side of the track rather than directly on top of the person's track. With this method if you lose the trail, you can backtrack and pick it up again and resume. If you have trampled all over it, you will have destroyed the clues.

When finding signs treat them the same as when finding search clues. Preserve them for analysis and report them.

Like all other search aspects, tracking takes much practice to develop the skill. The eye needs to be thoroughly trained, and then is used in conjunction with a knowledge of the bush.

Sight

- a) Smoke from campfires (day)
- b) Light from campfires (night)
- c) Light from torches (night)
- d) Footprints
- e) Clothing
- f) Pieces of foam sleeping mat
- g) Trail register
- h) Disturbed foliage
- i) Witnesses
- j) 'Discardables', such as lolly wrappers, drink or food cans, cigarette butts etc.

Appendix E-14 SAR Tasking Sheet Example

Task sheet example

SAR TASKING SHEET					
Incident No.		Task No.		How Tasked	
Date Task Issued		Time Task Issued		Call Sign	
Search Location				Radio Ch	
GPS Issued	Y/N	GPS No.		Radio No.	
Role	Name		DOB	Organisation	Phone
Team Leader					
Search Category			Search Pattern		
SEARCH BRIEF - Map attached Y/N					
Time Out		Search Start		Search Finish	
Time In		T/L - Understood & Signed			
RESULTS					
Signed - T/L			Date & Time		
SARO/FSC COMMENTS - PFC USE					
Signed - SARO/FSC		Date & Time		Finalised	Y/N

Appendix E-15 Search for Skeletal Remains

Overview

The search for human remains from crime involves a number of techniques depending on the stage of decomposition of the target. Searches may be for the following target types:

- a) Grave sites, deep or shallow: Searchers are looking for disturbances in the landscape, vegetation changes, dips or hollows, ground discolouration and cracking. It is near impossible to dig a grave and return the scene to its original condition. An aerial search may uncover potential sites of ground and/or vegetation disturbance. Historically, once a victim is buried, they are generally undisturbed until located by a search team, although there is evidence that shallow graves have been disturbed by wild and/or domestic animals.
- b) Disposal locations: Bodies may be quickly disposed of by criminals using what is readily available. (Covered with sticks and branches, leaf litter, rolled in carpet or other items, pushed into hollow items such as pipes and logs). There may be signs of darkened earth or dead vegetation caused by volatile fatty acids leeching from the body.
- c) Initial crime scene locations: The initial crime scene will provide forensic evidence and may be identified by signs of a struggle, broken branches, trampled grasses, ground disturbance, clothing, blood stains and/or other visible signs of a crime. This may not necessarily be the location of the victim.
- d) Skeletal remains and bone dispersion: Searches conducted after lengthy periods of disappearance may be looking for skeletal remains. The search for skeletal remains is dependent on a number of factors:
 - i) Length of time since initial incident: Skeletisation periods can vary from 2-3 years for persons buried in deep graves, 6-12 months for those in shallow graves and much shorter periods for those left on the surface or loosely covered. Cold weather will also slow the process of decomposition down, but warm, moist weather can have the opposite effect. Wildlife distribution in the area, insects, dogs, pigs, cats, birds and other carnivores will contribute to decomposition.
 - ii) Method of disposal: Burial inhibits decomposition due to a number of factors, including limited oxygen, limited exposure to flies and animals and generally cooler temperatures.
 - iii) Animal predation in area: Animals will hasten the decomposition of flesh, leaving only the skeletal remains. Evidence shows that bone dispersion often results from animal activity. There are some generalisations for bone dispersal:
 - During the initial stages of decomposition, the tendons and ligaments tend to hold a body together. This limits animal activity to removing flesh and softer body parts.
 - The body disarticulates from the outside in, with the limbs being the first to separate, allowing them to be moved by predatory animals. The skull will also separate from the vertebra and the neck vertebra from each other.
 - The limbs may be taken as a whole by predators, to be further disarticulated at other locations.
 - The skull is one of the last items to be moved due to its size and the difficulty in grasping it with teeth.
 - Bone dispersal is generally in an oval shape, with the body core being at the higher elevation focus of the oval. The limbs and other bones are mostly located in a downhill direction.
 - The oval shape is dependent on the terrain, with animals skirting rocky outcrops, thicker vegetation and waterways. The bone dispersion will generally follow animal tracks.
 - As limbs disarticulate, the dispersal pattern will go from the larger bones, femur and humerus, to the medium bones of the tibia, fibula, radius and ulna, to the individual hand and foot bones. The smaller bones are often difficult to recognise as bones, so it is

Appendices

recommended that a forensic osteologist be available on scene to assist with identification.

- The main section of the body will eventually collapse on itself with some of the smaller bones, such as ribs, being moved by animals.
- The length of the dispersal oval can be between 10 and 135 m depending on the local animal population. It is recommended that the latter be considered during the initial stages of the search.
- Bones can be discoloured by the environment and are often not the bleached white colour expected by searchers. They can take on the hues of the local environment due to the leeching effect of rain and the natural tannins found in plant life. The search briefing should be very clear on this point (Bone details are contained at end of this appendix).
- The age of the victim will also impact on what bones remain to be found. The bones of children and teenagers will not have fully ossified or calcified leaving only misshapen slivers or portions of bone to be discovered.
- Any objects suspected of being a bone should be examined *in-situ*, as the location of each bone can provide an indication of what position the victim was originally placed.



Figure E-15:1: Bone scattering

Two search methods are recommended for skeletal searching

- a) Single direction contact search. All search members are lined up shoulder to shoulder and proceed at a set pace through the search area. They should be armed with a hooked pole to move vegetation and other ground debris. Each member is responsible for their own search path. The usual rules on locating an object will apply. When a bone is located the searchers will commence a 'hands and knees' search of the area at least 10m around the located bone.
- b) Search teams start at opposite ends of the search area, shoulder to shoulder and walk towards each other. The teams pass and continue on to the end of the search area. While this is more labour intensive it does allow the area to be search twice, from different directions at once, increasing to probability of detection to beyond what would be possible from two separate searches.

The pre-search briefing must be comprehensive with respect to potential search objects, bone shape, colour and size, to ensure a thorough search is undertaken. Good investigative information is necessary to reduce the potential search area to a minimum as these types of searches are labour intensive, physically tiring and mentally straining.

Bone characteristics

Exposure on ground surface causes a number of effects:

- a) Bone collagen protein content is degraded by UV light and water (rain) exposure
- b) Bone mineral content is degraded by water exposure
- c) Overall, the loss of collagen is greater than the loss of bone mineral.
- d) The key phenomenon with ground surface exposure is transpiration.
 - Bone acts as a wick, drawing moisture from the soil and evaporating that moisture from the uppermost surface of the bone.
 - The result is the deposition of minerals from the soil pore water inside the bone cavities and the formation of surface crusts of evaporate minerals on the uppermost surface of the bone.
- e) Bones can be heavily degraded in as little as 2-15 years.

Surface exposed bones are typically white or light grey in colour, their surface is cracked or has a “woodgrain” appearance and is rough to the touch like sandpaper. Surface exposed bones often get snagged on clothing due to their rough texture.



Bone exposed on ground surface showing mineral crust formed on the uppermost surface of the bone due to transpiration



Bone exposed on ground surface showing brittle cracking due to loss of collagen

A series of 6 pictures of animal bones exposed on ground surface demonstrating cracking of the bone



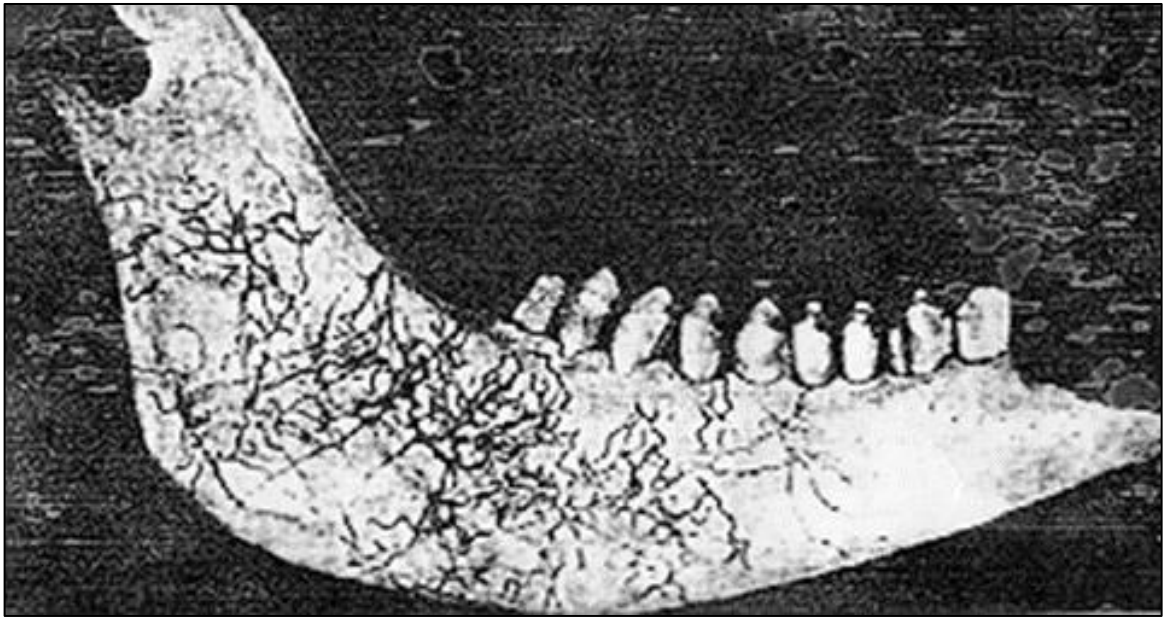


Cortex and “wood grain” appearance



Plant growth on bones

Plant root growth on bones causes shallow, etched depressions.





Plant roots may also obscure the shape of bones, making them difficult to detect. Buried up to 20 yrs.

Experiments had demonstrated that skeletonisation in Spain takes 3 yrs. Plant growth on bones would occur after skeletonisation.

- a) Plant growth consistent with person missing for 6 yrs. Rib case encased in shrub root growth consistent with >3 yrs growth.



Botanical evidence used in a Spanish case to demonstrate time since death.

- b) Plant growth consistent with person missing for 6 yrs. Bryophyte growth on exposed tibia. Bryophytes only grow on bone when organic matter is absent (i.e. after skeletonisation).

Appendices

Skeletonisation takes up to 3 yrs in Spain. Bryophyte annual segments on its stems indicates 3 yrs of growth.



Fungal growth on bones

Fungal attack indicates that the bone has been in an oxygenated environment. Fungi are stunted or do not grow in low oxygen/sealed environments.



Irregular white or dark grey patches of fungal growth on surface of human hip bone.

Predator damage to bones

Bone that has passed through a carnivore's digestive system. The bone cortex can be eroded to reveal the spongy bone underneath. There may be hair sticking to the bones from the rest of the carnivore's meal.



Appendix E-16 Peer Review Form Example

Overview

This is a Peer Review of a search and rescue operation under Volume 2 Chapter 6 of the National Search and Rescue Manual. This process is aimed at identifying issues within the SAR system and providing recommendations to address any such findings.

Peer review form

Reviewer	
Date of review	
Missing person/s	
Incident location	
Date of incident	
SAR Coordinator/s	
Reference number	
Review Sections	Outcomes (Suggested lines of enquiry)
Situation	<ul style="list-style-type: none"> a. A brief summary of the events leading to the incident. b. Summary of targets (description, age, experience, clothing, equipment carried, medical history, mental issues, disabilities). c. Summary of location, topography, vegetation, day light hours, weather, hazards d. Identification of SAR Coordinators and experience
The National SAR Arrangements	<ul style="list-style-type: none"> a. Does this incident fall into one of the categories identified in Appendix A-2? b. Which SAR authority was best placed to initiate a response? c. Which SAR authority was responsible for this incident?
Assessment of the survivability of the incident	<ul style="list-style-type: none"> a. Time elapsed since the incident; b. Environmental conditions; c. Age, experience and physical condition of (potential) survivors; d. Survival equipment available; e. Studies or information relating to survival in similar circumstances; f. Survivability of the incident g. Were survivors able to walk/drift away from incident site? h. Was there a possibility of third-party involvement
Assessment of the Last Known Position (LKP) or Splash Point (SP)	<ul style="list-style-type: none"> a. Calculations of LKP/SP utilising information available at the time. b. Correct application of current and leeway/ or Lost Person Behaviour c. Review the initial information available and any subsequent intelligence.
Examination of the search plan	<ul style="list-style-type: none"> a. Were proper assumptions were made on the information obtained b. Was a Search Urgency (SU) Form was completed c. Was the appropriate priority given to the urgency d. Were tasking sheets used, and signed upon return e. Were assigned areas were searched; f. Were resources activated and briefed in accordance with information g. Is a copy of the briefing/s available h. Was compensation made for search degradation caused by weather, navigation, mechanical or other difficulties
Assessment of the Time Frame for	<ul style="list-style-type: none"> a. Was an initial TFFS calculated and updated with medical advice b. Were POD calculations made

Survival (TFFS) and Probability of Detection (POD)	<ul style="list-style-type: none"> c. Was the POD of a sufficiently high value to provide the best chance of location of the target/s d. Were there factors that impacted on the POD
Assessment of the rescue plan	<ul style="list-style-type: none"> a. Was best use was made of available resources; b. Were contingency plans sufficient to cater with unexpected developments; c. Was coordination with other agencies was effective in ensuring best treatment of survivors. d. The probability of detection was as high as desired
Assessment of intelligence, information, clues and leads	<ul style="list-style-type: none"> a. Were all available sources of information used? b. Was a review done of the information obtained c. Was the intelligence collated and evaluated? d. Was the intelligence disseminated as necessary? e. Was all intelligence utilised, and appropriate weight given to it? f. Were items of information missed or overlooked? g. Was a SAR Log kept and available h. Were tasking sheets used, returned and filed i. Were data entry systems completed j. Was a termination Form completed and available k. What other strategies were used to locate target (Banks, ATO, Centrelink, Tolls, Telephone etc.)
Conclusion	<ul style="list-style-type: none"> a. Search location b. Urgency c. Sufficient and experienced coordinators d. SMC advised e. Value of search f. TFFS and POD g. Search reasoning h. Identified deficiencies in SAR (staffing, training, experience, support, POD)
Recommendations	<ul style="list-style-type: none"> a. Incident issues b. System issues or amendments c. Policy issues d. Support issues

Name:

Title:

Division/Branch/Unit/Police Station:

Distribution:

Original goes back to requesting Unit

Copy direct to State SAR Coordinator/Manager for information

Attachments

List attachments if applicable

Appendix E-17 Body Flotation Information

Overview

While as accurate as possible the data contained below is based on historical incidents throughout Australia. There has been no systematic study of human body flotation after immersion in water.

Humans have large numbers of bacteria within the body cavities such as the gut and chest. These bacteria don't immediately die when a body does but continue to metabolise and produce gas. It is this accumulation of body gasses that can raise a deceased body to the surface.

The actions of the surface, waves, and movement, combined with bird and animal activities quickly causes the built-up gas to dissipate into the atmosphere. Without this buoyancy a body will then sink back down, more than likely to never re-emerge.

Issues that will affect floatation times

- a) For every 10 m of depth the pressure increases by one (1) atmosphere. This means that for depths of 30-40 m or more the increased pressure and lower temperatures with generally retard any floatation of a body.
- b) Temperatures of below 5°C may not allow sufficient gas build-up for a body to float. In these instances, it may take until the water warms for any floatation to occur.
- c) Food ingestion is a factor that should be considered. A last meal high in carbohydrates will facilitate gas production, whereas a meal high in proteins will produce gas at a slower rate.
- d) Water temperature is an important factor for consideration. The below graph represents likely floatation times based on water temperature. This graph is based on reported floatation times for deceased bodies in inland waterways, rivers and dams. There is considerable leeway involved and is only to be used as a guide.
- e) Some medications and all alcohol will assist in gas production.
- f) Body composition is an important factor; a large obese person has more opportunity to float than a lighter muscled person. Fat or adipose is lighter than muscle mass.
- g) Children, although lighter, also have proportionally less gut. This can have the effect of slowing their floatation, and contrary to this, their higher proportion of body fat can aid in floatation.
- h) Clothing will impact the ability to float. It has been found that fishing waders and the like can inhibit floatation, whereas heavy clothing can require a significantly larger amount of gas generation for floatation. Layered clothing has been found to aid floatation in the short term, possibly through the retention of air between the layers, while in the long term is becomes an extra weight to be overcome. Light clothing and swimmers will generally have no effect.
- i) Any significant injuries to the body have been found to slow floatation. Open wounds, particularly in the chest and abdomen area can allow body gasses to escape, limiting floatation. The gasses produced by the body, hydrogen, hydrogen sulphide, carbon dioxide and methane, are all water soluble, meaning that they will dissolve if water is able to enter the body. Dissolved gasses have no lifting power. These gasses are also compressible, meaning that as depth increases their lifting power decreases.
- j) Because humans are not hydrodynamic in shape it takes very little in the way of snags to trap a body. The composition of the bottom in shallower areas can have an effect on floatation, things such as flood debris, rocks, car bodies etc. Mud and silt can have a strong vacuum suction effect on a body.
- k) People who are already deceased when they enter the water may not immediately sink. Without active respiration water entry into the lungs and gut may not immediately occur.
- l) Floatation of suicidal drowning victims can be problematic. Most of these people are weighted down by either an object such as a large concrete brick or layered clothing. Floatation does happen on occasion, but it is often more likely that they are located by a diver.

- m) Almost all bodies will surface face down, the arms and legs hanging down will cause this. Bodies thrown into the water during the early stages of rigor mortis may float face up, but this is rare.

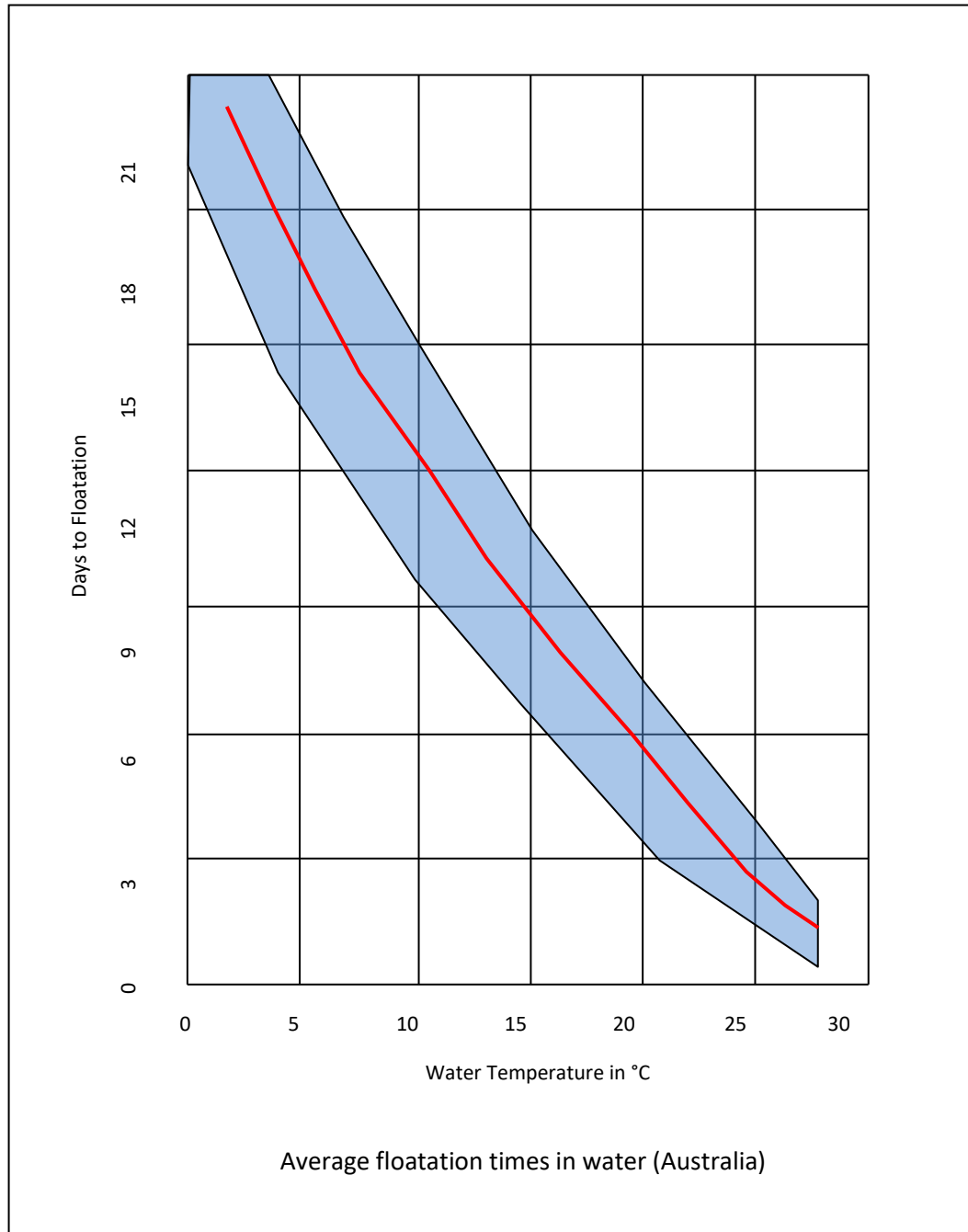


Figure E-16:1 Average floatation times in water (Australia)

Appendix F - Aircraft Electronic Night Search Guidance

Definitions

Term	Definition
EO/IR, or Electro-Optic/Infrared systems	Electronic imaging systems which include both visible and infrared sensors that can be used day and night and in low light conditions with the ability to view objects at long distance.
NVD, or night vision device	Night vision enhancement equipment fitted to, or mounted in or on, an aircraft, vessel or vehicle, or worn by a person, that can: <ol style="list-style-type: none">1. detect and amplify light in both the visual and near infrared bands of the electromagnetic spectrum; or2. provide an artificial image representing topographical displays.
NVIS, or night vision imaging system	A self-contained binocular night vision enhancement device, usually including goggles, that: <ol style="list-style-type: none">1. is helmet mounted or otherwise worn by a person; and2. can detect and amplify light in both the visual and near infrared bands of the electromagnetic spectrum. <p>NVIS is a term used to incorporate all aspects associated with night vision, including NVD.</p>

General Considerations

1. This information provides general guidance for search planners when considering night searches by aircraft using Electro-Optic/Infrared (EO/IR) equipment and/or Night Vision Imaging Systems (NVIS).

Note 1 - day searches using visual observation plus EO may be beneficial, but this guidance focuses on night search only.

Note 2 – NVIS is used in this guidance as a collective term incorporating all aspects associated with night vision such as Night Vision Devices (NVDs) and Night Vision Goggles (NVGs).

2. It is preferable, safer, and normally more effective to search in daylight. Of course, the timing of distress situations is not always optimal for a daylight search. Where suitably capable night search aircraft with aircrew trained and competent in safe night search operations are available, SMCs may consider a night search is necessary where the urgency of the situation may be critical to saving lives.
3. Factors generally common to selection of aircraft and the ability for pilots to safely accept any search task apply such as regulatory requirements, risk factors, aircraft performance and capability, equipment fitted, aircrew training and experience, weather, nature of search area (topography, vegetation, distance offshore, availability of forced landing areas, obstacles, and powerlines, etc), fuel endurance available, transit times, available time on scene, fatigue, etc.
4. Search planners and coordinators should have a good understanding of the capability and limitations of EO/IR and NVIS searching to be able to discuss and brief an effective search plan with the aircrew to establish reasonable expectations of possible outcomes and best use of the asset. Given the range of variables for these types of searches, search planners should be guided by the aircrew's expertise and plan the search accordingly with safety of the operation the priority.

Aircraft and equipment factors

5. Aircraft type and the type of EO/IR and NVIS equipment available on board provide different search options. Aircrew training and experience play a central role in night search effectiveness.
6. Ideally the use of a combination of EO/IR and NVIS is the most effective. NVIS can provide a wide viewing area with any sightings being able to be examined in more detail using IR which has a narrower

field of view and greater acuity. EO/IR cameras with the ability to zoom in on sightings provides advantages over EO/IR systems without this capability. Aircraft lighting, both internal and external, needs to be compatible with NVIS.

7. It is possible that an object can be visible in the NVIS but not be visible in the EO/IR, or vice versa depending on the object's characteristics. This may present challenges where search aircraft equipped with only one of these two types of electronic night search capability needs to transfer sighting details to another search aircraft with the other means of detection for investigation.
8. Advanced systems integrated with navigation systems, moving map displays and recording capabilities provide additional benefits to assist operators to provide greater search integrity, efficiency, and effectiveness. For search aircraft suitably fitted, the ability for the RCC to send search patterns and search areas via data files (e.g., KML files) to be uploaded to aircraft mission management systems, GNSS units or aircrew portable electronic devices (if equipped) can provide efficiencies by reducing the need for complex conversations, relay of information and human error. Such aircraft if also fitted with a GNSS flight tracking system may also be able to provide the RCC with a debrief of the actual search tracks flown.
9. Visual and IR lasers are visible using NVIS. SAR coordinators should note that some aircraft operators may have visual or IR laser capability which may be used for the purpose of guiding other aircraft and surface SAR units to a distress location. IR lasers can also be used by crew members on the same aircraft operating with different sensors to help each other acquire a sighting, for example, the crew member operating the EO/IR is having difficulty acquiring a sighting detected on NVIS by another crew member. Depending on the laser type there may be hazards associated with their use. SAR units who intend to use lasers should be appropriately authorised and trained in their use. Other assets involved in a search operation, both aircraft and surface units, should be informed when lasers are being used by search assets so they can take their own precautions with respect to laser safety and prevent confusion as to the reason for the laser.
10. Aircraft fitted with an external public address or loudhailer system may assist with providing verbal directions to a person on the surface and may give comfort to a missing person not yet located that they are being looked for.
11. Safety and capability can be enhanced for aircraft fitted with a terrain warning system, weather, or ground mapping radar and, for helicopters, auto-hover.
12. Some Light Emitting Diode (LED) lighting systems, clearly visible to the naked eye, fall outside the combined visible and near-infrared spectrum of NVIS and therefore will not be visible to aircrew using NVIS. This may present a hazard where LED lighting is used for surface obstacles. Emergency or other equipment fitted with LED lighting used by survivors may also impact detectability using NVIS.
13. Poor visibility due to contaminants in the air such as dust or smoke may compromise EO/IR and NVIS effectiveness. In maritime areas, strong winds can blow salt spray across camera lenses and windows obscuring the electronic image or view through windows, potentially leading to missed detection. Rain in the area can help clear this residue away.
14. In maritime areas, detectability of unlit targets on the sea surface using NVIS will be degraded, particularly in calm conditions because of the low albedo (reflective properties) and contrast.

Survivor factors

15. Search success can be limited where people being searched for are not actively trying to be located or are not capable of actively aiding search crews, for example due to exposure or injury, or if they are hiding.
16. Ideally persons in distress will have a light source which can be easily seen by NVIS equipped crews, such as a torch, light from a mobile phone or signal fire. Reflective material may also assist. It is also possible that laser pointers may be used by persons in distress.
17. A person in the water without a light or reflective surface in broad scale searches where a specific splash point is not known is very difficult to locate at night. A known splash point with a short time frame between the splash point time and arrival of the search aircraft will increase the probability of locating the target.

Appendices

-
18. To assist survivor awareness of the presence of the search aircraft and to elicit a survivor response signal, when the aircraft first arrives in the search area, if possible, the aircraft should be made as conspicuous as it can be by flying through the search area or orbiting at lowest safe altitude with as many external lights visible before commencing the search pattern.
 19. A person in distress may see or hear the search aircraft and respond by activating a light or flare. Crews should be alert that it is possible the person in distress may not have had the opportunity to activate their light signal by the time their aircraft passes and where possible adjust their search technique accordingly, for example, by flying both directions along the same search leg or, if capable and practicable, directing their detection equipment to search both forward and behind the aircraft.
 20. Survivor morale can be lifted when a search aircraft is sighted or heard during the night, even if the search aircraft does not find the survivor.

Search planning factors

21. The timeliness and accuracy of intelligence information for search area determination has a bearing on search effectiveness.
22. Search coordinators should also consider that a NVIS capable aircraft may not necessarily be capable of conducting a NVIS search. This is because:
 - a) NVIS may be used by pilots and aircrew solely for the purposes of safe air navigation and terrain avoidance functions in compliance with aviation regulations and may not have any capacity to conduct dedicated NVIS searching, whereas
 - b) other aircrew not directly involved in air navigation and terrain avoidance functions may use NVIS solely for the purposes of searching and observation.
23. Search planning should also take into account that search crews, when using EO/IR and NVIS equipment, will need periodic breaks to manage operator fatigue and provide an opportunity to view the search area with unaided electronic vision which may pick up lights that both EO/IR and NVIS cannot.
24. It is important to note that aircraft EO/IR equipment can normally only search one side of a search leg at a time, or only a forward or rear splay area at any time. Using NVIS to detect possible search targets, then using the EO/IR to investigate those sightings is generally the most effective search technique especially for small targets.
25. The target type will influence the type of night search to be conducted. Considerations include whether the primary target is to be a person, aircraft, vessel, or other object, its size, and its potential to provide a light source or light signal, and the amount of heat it may produce. The potential condition of the target should also be considered such as whether a survivor is likely to be capable of signalling or moving, a distressed aircraft has been damaged, or a vessel has capsized or is semi-submerged.
26. Night searches may be more effective in areas with reduced numbers of people to avoid false sightings. Wildlife and livestock can be a distraction.
27. Environmental conditions to consider include:
 - a) **Weather conditions** - both for search effectiveness and compliance with flight operations regulations, such as NVIS minima, ability to maintain visual meteorological conditions (VMC), risk of inadvertently entering instrument meteorological conditions (IMC), availability of optimal search altitude due to amount of cloud cover, precipitation, visibility, the action of wind over terrain and impacts of turbulence, freezing level, surface and air temperature, humidity, fog or mist, thunderstorms and sea conditions.
 - b) **Ambient light** - amount of moonlight and moon phase, position and elevation, effect of twilight and other ambient light sources. Nights with good ambient light enables more effective searching with NVIS.
 - c) **Thermal crossover** - the natural phenomenon that normally occurs twice daily when temperature conditions result in a loss of contrast between two adjacent objects on IR imagery which may have an adverse effect on IR detection.

-
- d) **Bushfire activity** - EO/IR detection capability will be affected by the heat from the fire(s). NVIS detection capability will be affected by the light from the fire(s) which can cause blooming (distortion or blotting out of the image) and smoke can reduce visibility.
 - e) **Thunderstorms** – search aircraft should avoid thunderstorms by a safe distance to avoid the hazardous effects of severe turbulence, lightning, icing, etc. Distances from thunderstorms may be difficult to estimate visually when using NVIS and the fitment of airborne weather radar or other electronic detection devices to the aircraft will assist. The NVIS image may be adversely affected by lightning flashes.
 - f) **For searches over land** - the topography including type of terrain, type and degree of vegetation, ground cover such as snow, and shadows from overhanging rocks and cliffs can impact search effectiveness. Different terrain can have positive and negative impacts on night searches. For EO/IR, a hot night may cause image wash out and a lack of obvious contrast between hot and cold and cause other structures and material to maintain heat for a longer period. Rocky terrain can be difficult to search by EO/IR where objects have the ability to retain heat during the day and provide 'false positives' during a night search. Time spent by ground crews checking these sightings can limit overall search effort.
 - g) **For searches over water** - sea conditions will determine search effectiveness. Rough water, waves, choppy surfaces, and whitecaps can impede identification of people in the water. Whitecaps splashing over the head of a survivor limits detectability.
28. Searching over water presents different challenges to searching over land. Helicopter operations may be limited by the ability of the crew to maintain continuous visual contact using NVIS with land or a shoreline, including any illumination levels and potential hover references. Large areas of open water such as oceans can be difficult to comprehensively search. Operations in close proximity to coastline, islands or other obstacles can limit ability to search at optimum search altitude due to minimum safe altitude requirements.
29. A more finite and smaller search area would benefit from a low altitude and slow speed search however a vast expansive search area such as in an open rural environment might require a higher altitude and faster search speed to cover. Higher probability locations may need smaller and repeated sweep widths or multiple orbits depending on field of view and to vary the slant ranges to potentially reveal previously unseen detail. Lower altitudes and low search speeds are most suitable for searching for a person in the water.
30. For best use of available aircraft search time, the best search progression will generally be in order of firstly covering the Last Known Position, then the intended route, likely routes or locations based on local knowledge and intelligence, before a broad area search. For overwater searches, search planners will need to allow for drift of the target.
31. Search pattern and sweep width choice and suitability will be dependent on the various factors described in this guidance and should be guided by aircrew expertise. Search patterns using parallel legs may be best in some cases while flying orbits/circular patterns may be better. Adjustments may be required when the aircraft arrives in the search area due to the conditions encountered and aircrews should be provided with flexibility to adjust their search parameters where possible.
32. Search altitude variations may be applicable depending on the type of search, search aircraft type, its electronic night search capability and aviation regulatory requirements. The lowest safe search altitude at night over land is terrain and weather dependant but generally 1,500 – 2,000 feet above ground level (AGL) would be reasonable. For helicopters with NVIS capability and regulatory approval, lower altitudes may be possible where conditions allow, and it is safe to do so. Higher search altitudes may be optimal such as the those generally flown by AMSA's Challenger CL604 using a circle search technique which would normally be flown between 5,000 – 10,000 feet AGL and typically not above 15,000 feet AGL. As different aircraft operators, both civil and military, may have different capabilities and regulatory authorisations, SAR coordinators should be guided by the operator/aircrew on a case-by-case basis when planning search altitudes.
33. Searching areas of thick vegetation such as forested areas can be difficult. Searching over forested areas can be more effective at a higher altitude to allow for a higher viewing angle through the tree canopy. Circling an area of thick vegetation to provide a view from different angles may also assist.

Appendices

-
34. EO/IR and NVIS can fail to detect a person due to the limitations and variables outlined in this guidance, and depending on where and how they are situated, for example under thick vegetation, covered in mud, etc. Search planning decisions made regarding potentially discounting areas searched by EO/IR and NVIS need to be carefully considered and searching those areas again by different search methods are likely to be needed for better search integrity.
 35. Sector searches over a datum improve detectability through the cumulative effect of repeatedly covering the datum area. Circular patterns or orbits may also offer the same effect.
 36. Most night search operations are likely to occur outside controlled airspace and where more than one aircraft is to be used for searching in the same area, as for day searches, those aircraft should be planned to allow aircrew to maintain deconflicted operations, both laterally and vertically, not only for safety purposes but also to maximise available search time while minimising the need for pilots to organise self-separation with other aircraft. For helicopter NVD operations, Australian civil aviation rules (CAO 82.6, Appendix 3, 12 Close proximity flights) require those flights operating in close proximity to another aircraft to be a minimum of 250 metres horizontally and 500 feet vertically apart and to be arranged and discussed between the pilots in command of those aircraft before the close proximity flight begins. For operations within controlled airspace, Air Traffic Services (ATS) requirements will need to be factored into the planning in consultation with the responsible ATS unit.

Surface unit support

37. The success of night searches can be dependent on surface (land or marine) unit support to investigate sightings by search aircraft. The deployment of surface units in the search area in support of the aircraft night search may also assist the aircrew to establish suitable reference parameters for their sensor equipment for the search conditions.
38. Where aircraft and surface resources are to search concurrently, identification of high probability areas suitable for air search while surface resources search more easily accessible areas can provide more efficient search area coverage.
39. Where surface search personnel are likely to be present there should be a method for the aircraft search crew to easily identify them, for example, radio communications, identifying light signals, and IR strobes where aircraft NVIS are used. Surface units may be assisted by search aircraft to locate distress locations or identify a point of interest, for example by use of helicopter search lights to illuminate a search location or use of search aircraft laser systems

NOTE – see precautions regarding aircraft laser systems in *Aircraft and equipment factors* section above.

40. Helicopter night winching has limitations, especially overwater, where a suitable visual reference is required or an auto-hover capability. NVIS capability may assist to safely permit a night winching within regulatory requirements, however, using surface unit support to investigate sightings or perform a rescue presents a lower risk option.

Circle Search technique - General guidance

41. A circle search is based on the search aircraft having the capability to search using a combination of EO/IR and NVIS operating at a fixed distance around a datum. As the aircraft flies the circular search pattern, the aircraft's NVIS and EO/IR are used as search sensors. Observers are afforded a broad but less detailed view of the search area utilising NVIS while EO/IR may provide both a wide field of view for target acquisition and a detailed, narrow field of view for target investigation. Due to the nature of this search technique and aircraft bank angle, observers and search equipment only search from the one side of the aircraft, i.e., towards the inside of the circle.
42. The circle search flight profile depends on three key inputs:
 - a) A **datum** to define the centre of the search area;
 - b) A search radius, typically 3 NM for faster fixed-wing aircraft, to balance search area coverage against the aircraft's NVIS and EO/IR capability, aircraft handling characteristics and search platform stability. The optimum radius will depend on the aircraft performance limitations; and

-
- c) An altitude, normally between 5,000-10,000 ft AGL and typically not above 15,000 ft for aircraft capable of higher altitudes.
43. Search planners need to be guided by the aircrew as to the optimum circle search radius, search altitude and speed.
 44. The search area should be relatively confined and made up of terrain considered suitable for a circle search.
 45. Before the search is initiated, the aircrew sensor operator breaks the search area into several smaller areas defined by human made or geographic boundaries such as roads, rivers, and property lines. Multiple orbits of the search area allow for each sub-area to be observed from multiple angles until the crew is confident the entire area has been searched as effectively as possible within the limits of the aircraft sensor capability and search conditions. For this reason, circle searches are ordinarily confined to land areas and are not normally appropriate for over water searches due to the lack of maritime surface features available. However, if multiple fixed points of reference are available overwater, like islands, reefs, and mud flats, then a circle search may be an option if the search area is geographically constrained to those areas.
 46. For broader areas, several circle searches may be combined adjacent to each other to complete that area in stages, for example a search along a track. This is dependent, of course, on aircraft endurance, crew duty time and on-scene search time available.
 47. The number of circle searches required will depend on the time taken to clear each individual search area and this will depend on the nature of the terrain, weather, light levels, and aircrew operator skill.
 48. The nature of terrain will determine the ideal search altitude. For example, heavily wooded or mountainous terrain are best searched at higher altitudes to improve the look down capability of the EO/IR, but the ideal search height will always be secondary to the Lowest Safe Altitude.
 49. Cloud and/or poor visibility may compromise a circle search; however, the EO/IR capability can be utilised to look through cloud breaks where they occur.
 50. When search planners are considering tasking suitably capable aircraft for a sector or expanding square search, the use of a circle search should also be considered.

Index

121.5 MHz.....	75	Australian Transport Safety Bureau (ATSB).....	39
156.8 MHz (Marine VHF Channel 16).....	75	Available Search Asset Factors	117
2182 kHz	74	Aviation and Marine Basic Search Planning ...	123
243 MHz.....	75	Aviation and Marine Determination of Search Areas	127
4125, 6215, 8291, 12290 and 16420 kHz	75	Aviation and Marine Planning	127
Accepting Coordination for a Component of the SAR Event from another SAR Authority.....	44	Aviation and Marine Probability of Detection (POD).....	218
Accuracy of Navigation by Land Search Teams	277	Aviation and Marine Search Planning Steps...	118
Actions by JRCC Australia	107	Aviation and Maritime Communications.....	73
Additional considerations for Search Dogs	263	Aviation and Maritime Search Operations	209
Advising States of Foreign Persons in Distress	100	Aviation and Maritime Search Planning	118
Air Assets	242	Aviation Capability	46
Air Observer Training.....	68	Aviation SAR Incident	93
Air Wings/State and Community provided aerial assets Communications	86	Aviation Search and Rescue Units (SRU)	68
Air, Marine or Land Incident Information	98	Avoidance of Danger	308
Aircraft Accidents	306	Awareness and Initial Action	92
Aircraft Capability	248	Awareness and Initial Action Stages (Stage 1 and 2).....	95
Aircraft Incidents	123	Awareness Introduction	92
Airservices Australia	38	Barrier	285
AIS-SART	80	Beacon Detection	79
Alert Phase.....	101	Beacon Search Procedures	236
Alert Phase Procedures	103	Beacon Transmission Characteristics	235
Alert Phase Transition	104	Beacon Types	235
Alerting Post	41	Beacons.....	79
All Other Requests for Defence SAR Assistance	48	Behaviour of Lost People	195
Allocation Chart Presentation	253	Briefing Officer.....	56
Allocation Variations to Suit Particular Aircraft	252	Briefings	46, 205
Allocator/Planner	56	Bureau of Meteorology (BOM).....	39
Alpine Environment.....	160	Calculated Search Area.....	271
Area Swept	276	Calculating Leeway	135
Arid Environment	161	Calculation of Circles of Probability.....	130
Assessing Reports	112	Calculation of Search Time Available.....	249
Assistant SAR Mission Coordinator (A/SMC) Responsibilities and Duties.....	56	Calculation of Search Time Required.....	248
Aural Location of Beacons	237	Case Studies.....	317
Aural Search by Surface Craft.....	229	Casualties.....	62
Australian Communications and Media Authority (ACMA)	39	Civil Aviation Safety Authority (CASA)	40
Australian Defence Force Air Assets.....	245	Civil SAR Equipment.....	311
Control of ADF Aircraft	245	Cloud Cover.....	215
Australian Defence Force Responsibilities – Military SAR	38	Cloud Cover and Sun Light.....	274
Australian Maritime Safety Authority (AMSA) ..	36	Clue Recognition and Interpretation	295
Australian Search and Rescue Region	48	Clue Time Sequence	296
Australian States and Land Search Area.....	50	Clues or Messages	296
		Coastal Search (Islands and their Foreshores)	229
		Coastal Search Planning.....	141
		Command/Communications Caravans	86
		Commercial and Private Organisations	40

Common Land Search Patterns	283	Daylight Factor.....	115
Communication Capabilities of State & Territory		Decision Points.....	177
SAR Authorities.....	86	Deductive Strategy	179
Communication Checks	106	Defence Requests for Civil Assistance	48
Communication Checks for Marine Craft	106	De-tuning Method	238
Communication Requirements.....	88	Distress Alerts	95
Communication Search	103	Distress and Emergency Signals.....	73
Communications.....	88	Distress Beacons	234
Communications Aircraft.....	86	Distress Phase.....	101
Communications Capabilities Australian Defence		Distress Phase Procedures.....	105
Force Ships and Aircraft.....	83	Distress Phase Transition.....	106
Communications Checks for Aircraft.....	107	Divergence	135
Communications Facilities.....	83	Drift Compensation	233
Communications in Support of SAR Operations	82	Drift Considerations.....	120
Communications Officer.....	88	Drift Error (De).....	137
Communications Relay Aircraft.....	256	Drift Error for Waterborne Targets.....	130
Comparison of Search Time Required and Time		Dropmaster and Dispatchers.....	68
Available for Search Aircraft.....	250	Dropmasters, Dispatchers and Observers	58
Composition of Contact Search Teams	271	Echelon Pattern	292
Conclusion General.....	313	Effective Consultation and Coordination.....	42
Conclusion of a successful SAR operation	313	Effective Search Time	250
Conclusion of SAR Operations.....	313	Effects of Alcohol	327
Conducting an Appreciation	150	Electronic Searches.....	234
Conducting the Debrief	316	ELT.... 78, 79, 93, 98, 105, 122, 222, 235, 236, 355	
Consideration of Possible Courses of Action by		Emergency Management Australia (EMA)	39
the Captain of the Distress Craft	141	Emergency Phases	100
Considerations for Air Assets	265	Emergency Signalling Devices.....	76
Contact Search.....	271	EPIRB..... 78, 81, 98, 105, 122, 222, 235, 309, 355	
Contact Search Considerations.....	271	Equipment for Marine Craft	247
Contour Search by Aircraft	230	Estimating the Distress Incident Location	119
Contour Search by foot.....	290	Evaluating the Situation.....	119
Control of ADF Aircraft	245	Evaluation of Notification Reports	96
Controlling Factors	124	Evidentiary Searches.....	207
Cooperation with Foreign Rescue Coordination		Examination of Recorded Communications -	
Centres.....	42	Aircraft and vessels.....	112
Coordination.....	198	Execution Factors:.....	205
Coordination Principles with Foreign RCCs	42	Expanding Square	291
Coordination with the Police.....	112	Expanding Square Search	225
COSPAS-SARSAT Distress Beacon Detection		Explanatory terms.....	262
System	77	Factors Affecting the Search Response Plan ..	122
Courses Open	152	Fast/Reconnaissance Search	269
Coverage Factor (C)	218	Fatigue Factor	214
Crashed Aircraft Communication Checks	107	Field craft	69
Creeping Line Ahead.....	289	Field Search Headquarters.....	200
Creeping Line Patterns	224	First Aid Training.....	68
Currents	131	First and last search light.....	115
Customs and Border Force Aircraft	245	First Search Light/Last Search Light.....	216
Customs Vessels	246	Fishing Vessels	85
Dangerous Animals.....	169	Flare Searches.....	234
Datum Considerations.....	120	Flight Path Analysis - Aircraft.....	113
Datum Plot.....	136	Forensic Searching	166
Day and Night Factors	216	Formal Search	172
Daylight Devices	76	Forward Command Post.....	52

Index

Forward Net.....	89	Land Assets	260
Frequencies	89	Land Assets in Aircraft Search	258
General	63	Land Environments	157
General - Communication Checks	106	Land SAR Additional Aircraft.....	267
General considerations.....	148	Land SAR First and Last Search Light	274
General Considerations for the SMC.....	113	Land SAR Incident	94
General Guidelines for Searches	209	Land SAR Meteorological Visibility	273
General Search	270	Land SAR Night Searching.....	277
General Search Method.....	270	Land SAR Probability of Detection.....	275
General Time Factors.....	114	Land SAR Resources.....	167
Geographical Coordinates	254	Land SAR Target Type	273
Global Maritime Distress and Safety System (GMDSS).....	75	Land SAR Training	67
Global SAR System Organisation	35	Land Search Action Plan	267
GMDSS Distress, Urgency, Safety and Calling Frequencies	74	Land Search and Rescue Units (SRU)	266
Good Search Conditions	147	Land Search Area Coverage	272
Guidance in Support of Transferring Coordination of a Component of a SAR Operation	45	Land Search Assets	260
Headquarter Requirements.....	88	Land Search Briefings.....	297
Headquarters Joint Operations Command.....	38	Land Search Communications	87
Health Hazards	306	Land Search Considerations for Air Assets	265
Health Hazards - Aircraft Accidents.....	108	Land Search Facilities.....	247
Heat Exhaustion.....	328	Land Search Helicopters	267
Heat Stroke	329	Land Search Operations.....	259
Hill Shading	238	Land Search Patterns	281
Hyperthermia Survivability.....	330	Land Search Planning.....	148, 170
Hyperthermia, Heat Stress and Dehydration ..	328	Land Search Private aircraft.....	267
Hypothermia.....	321	Land Search problems	201
Hypothermia Survivability	326	Land Search Seaplanes	267
Immediate Response	268	Land Search Speed.....	274
Incident Command	149	Land Search using Marine Assets	265
Incident Debriefs	315	Landmarks.....	254
Information: SAR Incident Information	96	Leeway	134
Initial Action: Procedures of the Emergency Phases.....	102	Lesson for improvement.....	317
Initial Actions.....	199	Liaison Officer	57
Initial Response	41	Liaison Visits.....	72
Initial Search Procedures	122	Liaison with Relatives	62
Inmarsat Aero	87	Limited Coast Radio Stations	85
Insufficient Search Time	252	Line Abreast Helicopter Searches.....	233
Intelligence gathering.....	108	Lines of Communications - NAVY	84
Intelligence Gathering and Assessment	106	Local Wind Current	133
Intelligence Officer	56	Localised Emergency Assistance to Save Life ...	47
International Distress Frequencies - Guarded by Royal Australian Naval Ships	84	Locating a Beacon Signal Source by Homing Devices.....	237
Interviewing Witnesses	112	Locating a Signal from the Ground	238
Introduction.....	248	Logistical Information	113
Investigation time.....	249, 250, 297	Longshore Current	133
Investigation Time	250	Map Reading and Navigation	69
Irregularly Shaped Areas	233	Marine and Aviation SAR Asset Selection and Characteristics	242
JRCC Responsibilities	36	Marine and Aviation Search Area Coverage...	211
Labelling the Datum	140	Marine and Aviation Search Asset Allocation.	248
		Marine and Aviation Search Considerations ..	233
		Marine Communications	See
		Marine Radio Alarm Signal	73

Maritime Assets.....	245	Other Emergency Assistance and Services available from JRCC Australia	63
Maritime Border Command	39	Other Methods of Communications.....	91
Maritime Safety Information.....	63	Other Types of Distress Alerting Devices.....	80
Maritime SAR Incident.....	93	Over Sufficiency of Search Time	252
Maritime Search Crews	257	Overall.....	41
Marking Targets.....	309	Overview	40, 51, 57, 59
Mass Casualty SAR Incidents	197	Parachute Drift.....	123
Mattson Consensus	303	Parallel Sweep (Multiple Teams)	288
Maximum Radio Signal Range Calculations.....	237	Parallel Sweep (Single Team).....	287
Maximum Search Effort.....	125	Parallel Track Pattern Multi-Unit.....	223
MEDEVAC.....	37, 93, 94, 311	Parallel Track Pattern Single Unit	223
Medical Assistance	306	Parallel Track Search Pattern.....	222
Medical Assistance to Vessels at Sea	37	Passive Searching.....	208
Medical Factors	320	Peer Reviews.....	318
MEOSAR.....	78	Person in Water	147
Merchant Shipping and GMDSS	84	Person Overboard Incident Information	98
Meteorological Visibility	213	Personal Locator Beacon	78, 79, 93, 105, 122
MIR Liaison Officer	200	Personnel	58
Miscellaneous Factors	216	Phase Transition	103
Missing person.....	99	Photographic Records.....	72
Modification for the Allocation of Areas to Search Units Other than Aircraft.....	141	PLB	78, 79, 93, 105, 122, 222, 235, 355
Modification of Areas Incorporating De and Increased Safety Factors.....	141	Pleasure Craft	85
Modification of the Probability Area.....	140	Plotting Drift	136
Modification Resulting from a Shortage of Search Aircraft.....	140	Point and Flank	284
Modification Suggested by Intelligence Information.....	140	Poor Search Conditions	147
Mountain Considerations	164	Position of the Sun.....	215
Mountain Environment	163	Position Uncertainty	144
Mountain Environment Search Strategies	165	Possibility Area.....	127
Mountainous or Rugged Terrain Searches	232	Possible Location of a Distressed Target	122
National and Regional SAR System Organisation	35	Preparation - Land search briefings.....	298
National Training Framework.....	65	Press Releases.....	60
Naval Vessels	246	Probable Errors of Position.....	130
Navigation of SAR Units.....	220	Procedures and Practices	91
Night Factor	115	Provision for Entry of Foreign Aircraft during SAR Operations	43
Night Time Multi-Unit Searches	233	Public Relations.....	59
Night Vision Goggles.....	241	Public Relations Officers (PRO's)/Media Officers (MO).....	60
Night-time Devices	76	Purpose.....	78
Notification by Airservices Australia	95	Purposeful Meandering.....	286
Notification of Next of Kin	62	Qualifications.....	65
Objects/evidence.....	99	RADAR/IFF/SSR	77
Observation Skills	69	Radio and Distress Beacons.....	77
Observation Skills-Day	69	Radio Operating Procedures.....	69
On Scene Coordinator	57	Radios in general	90
Operations involving two or more SAR Authorities	60	Radiotelephony Distress/Emergency Frequencies	74
Organisation	35	Rainforest.....	157
Other Commonwealth Agencies/Authorities.....	39	RCC/Field Search Headquarters (FSH) Staff.....	53
		Rear Net	89
		Reasons for Transfer of Coordination.....	43
		Recomputed Datum.....	145

Index

Record Keeping.....	206	Search Area Based on Non-Moving Datum	138
Recorder/Logger.....	56	Search Area Delineation	202
Recording of Events.....	94	Search Area Description	254
Recording of search areas	188	Search Based on Moving Datum.....	138
Records and Reports	315	Search Briefing.....	254
Reflex Search	269	Search by Infrared (IR) Devices.....	241
Reopening a Suspended Search	315	Search by RADAR	239
Requesting JRCC Australia Assistance	46	Search Dog Capabilities	261
Requesting Public Assistance	61	Search Dog teams in Australia	264
Requests for Assistance from Foreign RCCs	43	Search Effort Expenditure Rate	125
Requests for Defence Assistance (DACC)	47	Search Pattern Abbreviations.....	255
Requirement for Training	65	Search Pattern Conclusion.....	295
Requirements for SAR Training	65	Search Planning and Evaluation.....	118
Rescue Assets	310	Search Radius (R)	130
Rescue at Sea.....	308	Search Response Stages	121
Rescue General.....	305	Search Sequence.....	125
Rescue on Land.....	307	Search Strategies for Land SAR.....	268
Rescue Planner	57	Search Team Leaders/ On-Scene Commanders	71
Rescue Planning Operations.....	305	Searchers	71
Rescue Preparation	59	Searchers or Clue Seekers	296
Responsibilities as Air Search Coordinator.....	47	Searching	201
Rip Current.....	133	Searching in Hazardous Areas	278
Risks v Gain Factors	117	Sector Search	227
River Current	132	Sector Search Pattern for a Vessel	228
RTF Distress Signal.....	74	Seeking Medical Advice	333
RTF Safety Signal.....	74	Ship Stations	85
RTF Urgency Signal	74	Sighting and Hearing Reports	111
Safety Frequencies	75	Signal Heard, Signal Fade Plotting Method	237
SAR Authority Best Placed to Coordinate.....	41	Single File Search	283
SAR Authority Responsibilities	51	Situational Awareness	149
SAR Call Signs.....	82	Specific factors of LPB that may affect search planning:	195
SAR Coordination.....	40, 47	SPOT Personal Satellite Messenger device (SPOT)	80
SAR Crew Briefing.....	253	Square Search	287
SAR Crew Debriefing.....	259	SRR Coordinates.....	49
SAR Frequencies	82	Stage One Search: Immediate response.....	209
SAR Management.....	51	Stage Three Search: Mathematically Derived Area	211
SAR Mission Coordinator (SMC)	54	Stage Two Search: Nominated Area Either Side of Track	210
SAR RADAR Transponder (SART)	81	State and Territory Governments.....	37
SAR Stages	94	State Emergency Services (SES).....	260
SAR System Organisation	35	State/Territory Police Responsibilities	37
Satellites	78	State/Territory SAR Authority Training	66
Sea Current.....	131	Statistical Strategy (Lost Person Behaviour)...	174
Search Aircraft Height	214	Subject Matter Expertise and Advice	46
Search Aircraft Operations	256	Subject or Clue Generator	296
Search Aircraft Speed	214	Subjective/Decision Point Strategy	176
Search Aircrew Briefing	255	Sufficient Search Time for Search Aircraft.....	251
Search and Rescue Crew Training	68	Supply Drop from Aircraft over Land.....	312
Search and Rescue Exercises	67	Supply Drop from Aircraft over Sea.....	312
Search and Rescue Resources	57	Supply Drop from Helicopter over Sea	312
Search and Rescue Roles	54		
Search and Rescue Techniques	209		
Search and Rescue Visual Signals	84		
Search Area.....	141, 296		

Supply Dropping and Delivery of Survival Equipment	311	Type of Aviation and Marine Target	213
Surf Current	133	Type of Terrain/Conditions	273
Survival Environment Factors	320	Type of Terrain/Conditions of the Sea	213
Survival Equipment Factors	117	Types of Notification Reports	95
Survivor	80	Types of SAR Incidents	92
Survivor Stress Factors	320	Uncertainty Phase	100
Suspension/termination of a search when the target is not found	313	Uncertainty Phase Initial Action	102
Sweep Width (W): Factors affecting Sweep Width	212	Uncorrected Sweep Widths for Fixed-Wing Aircraft (NM) at 500 ft and 1000 ft	394
Sweep Width Calculations (W)	217	Universal Grid Reference	254
Swell/Wave Current	133	Unlawful Acts	63
Tasking Search Dog teams	264	Urban SAR (USAR)	198
Tasking sheets	204	Urban Search Patterns	293
Tasks of Contact Search Teams	271	Urban searching	165
Team and Individual Skills	70	Urgency of Response	114
Telephone Triangulation	170	Use of Aircraft for Rescue	310
Telephone/Radio	89	Use of Helicopters for Rescue	310
Terrain Factors	116, 156, 332	Use of Merchant Shipping	246
Theoretical Search Strategy (Naismith's Rule)	172	Use of Rescue Boats and Vessels	309
Thuraya Satellite Devices	81	Use of Top Cover Aircraft with Rescue and MEDEVAC Helicopters	311
Tidal Streams	131	Using all four Formal Search Strategies	179
Time Frame for Survival (TFFS)	320	Using Search Dog capability for SAR	263
Top Cover Aircraft	257	Vehicle Search Patterns	292
Track Line	254	Visual Horizon: Ankle Rule	275
Track Line Overdue Incident	144	Visual Search Patterns (Marine and Aviation)	221
Track Line Search	224	Volunteer Organisations	40, 86
Track Spacing	147	Water Hypothermia	321
Track Spacing (S)	217	Water Immersion	327
Track Sweep	284	Weather Analysis	113
Training	65	Weather/Oceanographic Factors	115
Training and Exercises	65	Wet-Chill Survivability	326
Transfer of Coordination	43	Who to Train	65
Transfer of Coordination after Suspension of SAR Action	45	Wind Chill	325
Transferring Overall Coordination	44	Wind Hypothermia	324
		Working under or within a MIR	199
		Z (Investigation Time)	249, 250, 297