

# HSC Code - International Code of Safety for High Speed Craft, 1994

**Resolution MSC.36(63)**

**Amended by Resolution MSC.119(74)**

**Amended by Resolution MSC.174(79)**

**Amended by Resolution MSC.221(82)**

**Amended by Resolution MSC.259(84)**

## The Maritime Safety Committee

. RECALLING Article 28(b) of the Convention on the International Maritime Organization concerning the functions of the Committee,

. RECALLING FURTHER resolution A.373(X) by which the Assembly, when adopting on 14 November 1977 the Code of Safety for Dynamically Supported Craft (DSC Code) for craft such as hydrofoil boats and air-cushion vehicles which were increasingly being introduced in international transport, authorized the Maritime Safety Committee to amend the DSC Code as may be necessary,

. RECOGNIZING the continual development of novel types and sizes of high speed craft, which are not necessarily dynamically supported, cargo craft, passenger craft carrying larger numbers of passengers or operating at greater distances from places of refuge than permitted by the DSC Code,

. RECOGNIZING FURTHER that improvements of maritime safety standards since the adoption of the DSC Code are required to be reflected in the provisions for the design, construction, equipment and operation of high speed craft in order to maintain certification and safety equivalence with conventional ships,

. NOTING that the SOLAS Conference to be held from 17 to 24 May 1994 will be invited to adopt amendments to the 1974 SOLAS Convention which, inter alia, include a new chapter X on Safety measures for high speed craft, to make the provisions of the International Code of Safety for High Speed Craft (HSC Code) mandatory under that Convention for all such craft constructed on or after 1 January 1996,

. HAVING CONSIDERED at its sixty-third session the text of the proposed HSC Code which has been developed following a thorough revision of the DSC Code,

1.. ADOPTS the HSC Code, the text of which is set out in the Annex to the present resolution;

2.. NOTES that under the proposed chapter X of the 1974 SOLAS Convention, amendments to the HSC Code shall be adopted, brought into force and shall take effect in accordance with the provisions of article VIII of that Convention other than chapter I;

3.. REQUESTS the Secretary-General to transmit a copy of the present resolution together with the text of the HSC Code to all Members of the Organization and to all Contracting Governments to the 1974 SOLAS Convention which are not Members of the Organization;

4.. RECOMMENDS Governments to apply the Code on a voluntary basis in respect of craft constructed between the adoption of this resolution and the entry into force of the amendments to the 1974 SOLAS Convention referred to above as may be adopted by the 1994 SOLAS Conference.

# Annex - International Code of Safety for High Speed Craft, 1994

## Preamble

1. The international conventions ratified in respect of conventional ships and the regulations applied as a consequence of such conventions have largely been developed having in mind the manner in which conventional ships are constructed and operated. Traditionally, ships have been built of steel and with the minimum of operational controls. The requirements for ships engaged on long international voyages are therefore framed in such a way that, providing the ship is presented for survey and a ship safety certificate is issued, the ship may go anywhere in the world without any operational restrictions being imposed. Providing the ship is not involved in a casualty, all that is needed is that it is made available to the Administration for the purpose of a satisfactory resurvey before the ship safety certificate expires and the certificate will be reissued.

2. The traditional method of regulating ships should not be accepted as being the only possible way of providing an appropriate level of safety. Nor should it be assumed that another approach, using different criteria, could not be applied. Over a long period of years, numerous new designs of marine vehicles have been developed and have been in service. While these do not fully comply with the provisions of the international conventions relating to conventional ships built of steel, they have demonstrated an ability to operate at an equivalent level of safety when engaged on restricted voyages under restricted operational weather conditions and with approved maintenance and supervision schedules.

3. This Code has been derived from the previous Code of Safety for Dynamically Supported Craft (DSC) adopted by IMO in 1977. The Code recognized that safety levels can be significantly enhanced by the infrastructure associated with regular service on a particular route, whereas the conventional ship safety philosophy relies on the ship being self-sustaining with all necessary emergency equipment being carried on board. This revised Code has been prepared in recognition of the growth in size and a type of high speed craft now existing and is intended to facilitate future research and development of fast sea transportation in order that they may be accepted internationally.

4. The safety philosophy of this Code is based on the management and reduction of risk as well as the traditional philosophy of passive protection in the event of an accident. Management of risk through accommodation arrangement, active safety systems, restricted operation, quality management and human factors engineering should be considered in evaluating safety equivalent to current conventions. Application of mathematical analysis should be encouraged to assess risk and determine the validity of safety measures.

5. The Code takes into account that a high speed craft is of a light displacement compared with a conventional ship. This displacement aspect is the essential parameter to obtain fast and competitive sea transportation and consequently this Code allows for use of non-conventional shipbuilding materials, provided that a safety standard at least equivalent to conventional ships is achieved.

6. To clearly distinguish such craft, criteria based on speed and volumetric Froude number have been used to delineate those craft to which this Code applies from other, more conventional, craft.

7. The Code requirements also reflect the additional hazards which may be caused by the high speed compared with conventional ship transportation. Thus, in addition to the normal requirements including life-saving appliances, evacuation facilities, etc., provided in case of an accident occurring, further emphasis is placed on reducing the risk of hazardous situations arising. Some advantages result from the high speed craft concept, i.e. the light displacement provides a large reserve buoyancy in relation to displacement, reducing the hazards addressed by the International Load Line Convention. The consequences of other hazards such as of collision at high speed are balanced by more stringent navigational and operational requirements and specially developed accommodation provisions.

8. The above-mentioned safety concepts were originally reflected in the Code of Safety for Dynamically Supported Craft. The development of novel types and sizes of craft has led to the development of pressures within the maritime industry for craft which are not dynamically supported cargo craft, passenger craft carrying larger numbers of passengers or operating further afield than permitted by that Code to be certified according to those concepts. Additionally, improvements of maritime safety standards since 1977 were required to be reflected in the revisions of the Code to maintain safety equivalence with conventional ships.

9. Accordingly, two differing principles of protection and rescue were developed.

10. The first of these recognizes the craft which were originally foreseen at the time of development of the DSC Code. Where rescue assistance is readily available and the total number of passengers is limited, a reduction in passive and active protection may be permitted. Such craft are called "assisted craft" and form the basis for "category A passenger craft" of this Code.

11. The second concept recognizes the further development of high speed craft into larger craft. Where rescue assistance is not readily available or the number of passengers is unlimited, additional passive and active safety precautions are required. These additional requirements provide for an area of safe refuge on board, redundancy of vital systems, increased watertight and structural integrity and full fire-extinguishing capability. Such craft are called "unassisted craft" and form the basis for "cargo craft" and "category B passenger craft" of this Code.

12. These two concepts of the Code have been developed as a unified document on the basis that an equivalent level of safety to that normally expected on ships complying with the International Convention for the Safety of Life at Sea is achieved. Where the application of new technology or design indicates an equivalent safety level to the strict application of the Code, the Administration is permitted to formally recognize such equivalence.

13. It is important that an Administration, in considering the suitability of a high speed craft under this Code, should apply all sections of the Code because non-compliance with any part of the Code could result in an imbalance which would adversely affect the safety of the craft, passengers and crew. For a similar reason, modifications to existing craft, which may have an effect on safety, should be approved by the Administration.

14. In developing the Code, it has been considered desirable to ensure that high speed craft do not impose unreasonable demands on existing users of the environment or conversely suffer unnecessarily through lack of reasonable accommodation by existing users. Whatever burden of compatibility there is, it should not necessarily be laid wholly on the high speed craft.

## **Chapter 1 - General Comment and Requirements**

### **1.1 General comments**

. This Code should be applied as a complete set of comprehensive requirements. It contains requirements for the design and construction of high speed craft engaged on international voyages, the equipment which should be provided and the conditions for their operation and maintenance. The basic aim of the Code is to set levels of safety which are equivalent to those of conventional ships required by the International Convention for the Safety of Life at Sea, 1974, as amended, (SOLAS Convention) and International Convention on Load Lines, 1966 (Load Line Convention) by the application of constructional and equipment standards in conjunction with strict operational controls.

### **1.2 General requirements**

1.2.1. The application of the provisions of this Code is subject to the following general requirements that:

.1. the Code will be applied in its entirety;

.2. the management of the company operating the craft exercises strict control over its operation and maintenance by a quality management system;

.3. the management ensures that only persons qualified to operate the specific type of craft used on the intended route are employed;

.4. the distances covered and the worst intended conditions in which operations are permitted will be restricted by the imposition of operational limits:

.5. the craft will at all times be in reasonable proximity to a place of refuge;

.6. adequate communications facilities, weather forecasts and maintenance facilities are available within the area of operation;

- .7. in the intended area of operation there will be suitable rescue facilities readily available;
  - .8. areas of high fire risk such as machinery spaces and special category spaces are protected with fire-resistant materials and fire-extinguishing systems to ensure, as far as is practicable, containment and rapid extinguishing of fire;
  - .9. efficient facilities are provided for the rapid and safe evacuation of all persons into survival craft;
  - .10. that all passengers and crew are provided with seats;
  - .11. that no enclosed sleeping berths for passengers are provided;
  - .12. where the Administration has made a comprehensive review of the adequacy of the fire safety measures and evacuation procedures for the crew accommodation, sleeping berths for crew may be permitted.
- 1.2.2. New installation of materials containing asbestos used for the structure, machinery, electrical installations and equipment of a craft to which this Code applies should be prohibited except for:
- .1. vanes used in rotary vane compressors and rotary vane vacuum pumps;
  - .2. watertight joints and linings used for the circulation of fluids when, at high temperature (in excess of 350°C) or pressure (in excess of  $7 \times 10^6$  Pa), there is a risk of fire, corrosion or toxicity; and
  - .3. supple and flexible thermal insulation assemblies used for temperatures above 1000°C.

## 1.3 Application

1.3.1. This Code applies to high speed craft which are engaged in international voyages.

1.3.2. This Code applies to:

- .1. passenger craft which do not proceed in the course of their voyage more than 4 h at operational speed from a place of refuge when fully laden; and
- .2. cargo craft of 500 gross tonnage and upwards which do not proceed in the course of their voyage more than 8 h at operational speed from a place of refuge when fully laden.

1.3.3. This Code, unless expressly provided otherwise, does not apply to:

- .1. warships, naval auxiliaries or other craft owned or operated by a Contracting Government and used only on government non-commercial service;
- .2. craft not propelled by mechanical means;
- .3. wooden craft of primitive built;
- .4. pleasure craft not engaged in trade; and
- .5. fishing craft.

However, warships, naval auxiliaries or other craft owned or operated by a Contracting Government and used only on government non-commercial service are encouraged to act in a manner consistent, so as far as reasonable and practicable, with this Code.

1.3.4. This Code does not apply to craft solely navigating the Great Lakes of North America and the River St. Lawrence as far east as a straight line drawn from Cap des Rosiers to West Point, Anticosti Island and, on the north side of Anticosti Island, the 63rd meridian.

1.3.5. The application of this Code should be verified by the Administration and be acceptable to the Governments of the States to which the craft will be operating.

## 1.4 Definitions

. For the purpose of this Code, unless expressly provided otherwise, the terms used therein have the meanings defined in the following paragraphs. Additional definitions are given in the general parts of the various chapters.

1.4.1. "Administration" means the Government of the State whose flag the craft is entitled to fly.

1.4.2. "Air-cushion vehicle" (ACV) is a craft such that the whole or a significant part of its weight can be supported, whether at rest or in motion, by a continuously generated cushion of air dependent for its effectiveness on the proximity of the surface over which the craft operates.

1.4.3. "Auxiliary machinery spaces" are spaces containing internal combustion engines of power output up to and including 110 kW driving generators, sprinkler, drencher or fire pumps, bilge pumps, etc., oil filling stations, switchboards of aggregate capacity exceeding 800 kW, similar spaces and trunks to such spaces.

1.4.4. "Auxiliary machinery spaces having little or no fire risk" are spaces such as refrigerating, stabilizing, ventilation and air conditioning machinery, switchboards of aggregate capacity 800 kW or less, similar spaces and trunks to such spaces.

1.4.5. "Base port" is a specific port identified in the route operational manual and provided with:

.1. appropriate facilities providing continuous radio communications with the craft at all times while in ports and at sea;

.2. means for obtaining a reliable weather forecast for the corresponding region and its due transmission to all craft in operation;

.3. for a category A craft, access to facilities provided with appropriate rescue and survival equipment; and

.4. access to craft maintenance services with appropriate equipment.

1.4.6. "Base port State" means the State in which the base port is located.

1.4.7. "Breadth (B)" means breadth of the broadest part of the moulded watertight envelope of the rigid hull, excluding appendages, at or below the design waterline in the displacement mode with no lift or propulsion machinery active.

1.4.8. "Cargo craft" is any high speed craft other than passenger craft, and which is capable of maintaining the main functions and safety systems of unaffected spaces, after damage in any one compartment on board.

1.4.9. "Cargo spaces" are all spaces other than special category spaces used for cargo and trunks to such spaces.

1.4.10. "Category A craft" is any high speed passenger craft:

.1. operating on a route where it has been demonstrated to the satisfaction of the flag and port States that there is a high probability that in the event of an evacuation at any point of the route, all passengers and crew can be rescued safely within the least of:

- the time to prevent persons in survival craft from exposure causing hypothermia in the worst intended conditions,
- the time appropriate with respect to environmental conditions and geographical features of the route, or
- 4 h; and

.2. carrying not more than 450 passengers.

1.4.11. "Category B craft" is any high speed passenger craft, other than a category A craft, with machinery and safety systems arranged such that, in the event of damage disabling any essential machinery and safety systems in one compartment, the craft retains the capability to navigate safely.

1.4.12. "Continuously manned control station" is a control station which is continuously manned by a responsible member of the crew while the craft is in normal service.

1.4.13. "Control stations" are those spaces in which the craft's radio or navigating equipment or the emergency source of power and emergency switchboard are located, or where the fire recording or fire control equipment is centralized, or where other functions essential to the safe operation of the craft such as propulsion control, public address, stabilization systems, etc., are located.

1.4.14. "Convention" means the International Convention for the Safety of Life at Sea, 1974, as amended.

1.4.15. "Crew accommodation" are those spaces allocated for the use of the crew, and include cabins, sick bays, offices, lavatories, lounges and similar spaces.

1.4.16. "Critical design conditions" means the limiting specified conditions chosen for design purposes, which the craft should keep in displacement mode. Such conditions should be more severe than the worst intended conditions by a suitable margin to provide for adequate safety in survival condition.

1.4.17. "Design waterline" means the waterline corresponding to the maximum operational weight of the craft with no lift or propulsion machinery active and is limited by the requirements of chapters 2 and 3.

1.4.18. "Displacement mode" means the regime, whether at rest or in motion, where the weight of the craft is fully or predominantly supported by hydrostatic forces.

1.4.19. "Failure mode and effect analysis (FMEA)" is an examination, in accordance with annex 4, of the craft's systems and equipment to determine whether any reasonably probable failure or improper operation can result in a hazardous or catastrophic effect.

1.4.20. "Flap" means an element formed as integrated part of, or an extension of, a foil, used to adjust the hydro- or aerodynamic lift of the foil.

1.4.21. "Flashpoint" means a flashpoint determined by a test using the closed cup apparatus referenced in the International Maritime Dangerous Goods (IMDG) Code.

1.4.22. "Foil" means a profiled plate or three dimensional construction at which hydrodynamic lift is generated when the craft is under way.

1.4.23. "Fully submerged foil" means a foil having no lift components piercing the surface of the water in the foil-borne mode.

1.4.24. "High speed craft" is a craft capable of a maximum speed in metres per second (m/s) equal to or exceeding:

$$3.7V^{0.1667}$$

where:

V = displacement corresponding to the design waterline

1.4.25. "Hydrofoil boat" is a craft which is supported above the water surface in non-displacement mode by hydrodynamic forces generated on foils.

1.4.26. "Length (L)" means the overall length of the underwater watertight envelope of the rigid hull, excluding appendages, at or below the design waterline in the displacement mode with no lift or propulsion machinery active.

1.4.27. "Lightweight" is the displacement of the craft in tonnes without cargo, fuel, lubricating oil, ballast water, fresh water and feedwater in tanks, consumable stores, passengers and crew and their effects.

1.4.28. "Machinery spaces" are spaces containing internal combustion engines with aggregate total power output of more than 110 kW, generators, oil fuel units, propulsion machinery, major electrical machinery and similar spaces and trunks to such spaces.

1.4.29. "Maximum operational weight" means the overall weight up to which operation in the intended mode is permitted by the Administration.

1.4.30. "Maximum speed" is the speed achieved at the maximum continuous propulsion power for which the craft is certified at maximum operational weight and in smooth water.

1.4.31. "Muster station" is an area where passengers can be gathered in the event of an emergency, given instructions and prepared to abandon the craft, if necessary. The passenger spaces may serve as muster stations if all passengers can be instructed there and prepared to abandon the craft.

1.4.32. "Non-displacement mode" means the normal operational regime of a craft when non-hydrostatic forces substantially or predominantly support the weight of the craft.

1.4.33. "Oil fuel unit" is the equipment used for the preparation of oil fuel for delivery to an oil-fired boiler, or equipment used for the preparation for delivery of heated oil to an internal combustion engine, and includes any oil pressure pumps, filters and heaters dealing with oil at a pressure of more than 0.18 N/mm<sup>2</sup>.

1.4.34. "Open vehicle spaces" are spaces:

.1. to which any passengers carried have access;

.2. intended for carriage of motor vehicles with fuel in their tanks for their own propulsion; and

.3. either open at both ends, or open at one end and provided with adequate natural ventilation effective over their entire length through permanent openings in the side plating or deckhead or from above.

1.4.35. "Operating compartment" means the enclosed area from which the navigation and control of the craft is exercised.

1.4.36. "Operating station" means a confined area of the operating compartment equipped with necessary means for navigation, manoeuvring and communication, and from where the functions of navigating, manoeuvring, communication, commanding, conning and lookout are carried out.

1.4.37. "Operational speed" is 90% of the maximum speed.

1.4.38. "Organization" means the International Maritime Organization.

1.4.39. "Passenger" is every person other than:

.1. the master and members of the crew or other persons employed or engaged in any capacity on board a craft on the business of that craft; and

.2. a child under one year of age.

1.4.40. "Passenger craft" is a craft which carries more than twelve passengers.

1.4.41. "Place of refuge" is any naturally or artificially sheltered area which may be used as a shelter by a craft under conditions likely to endanger its safety.

1.4.42. "Public spaces" are those spaces allocated for the passengers and include bars, kiosks, smoke rooms, main seating areas, lounges, dining rooms, recreation rooms, lobbies, lavatories and similar permanently enclosed spaces allocated for passengers.

1.4.43. "Service spaces" are those enclosed spaces used for pantries containing food warming equipment but no cooking facilities with exposed heating surfaces, lockers, sales shops, store-rooms and enclosed baggage rooms.

1.4.44. "Significant wave height" is the average height of the one third highest observed wave heights over a given period.

1.4.45. "Special category spaces" are those enclosed spaces intended for the carriage of motor vehicles with fuel in their tanks for their own propulsion, into and from which such vehicles can be driven and to which passengers have access, including spaces intended for the carriage of cargo vehicles.

1.4.46. "Surface effect ship" (SES) is an air-cushion vehicle whose cushion is totally or partially retained by permanently immersed hard structures.

1.4.47. "Transitional mode" means the regime between displacement and non-displacement modes.

1.4.48. "Worst intended conditions" means the specified environmental conditions within which the intentional operation of the craft is provided for in the certification of the craft. This should take into account parameters such as the worst conditions of wind force allowable, significant wave height (including unfavourable combinations of length and direction of waves), minimum air temperature, visibility and depth of water for safe operation and such other parameters as the Administration may require in considering the type of craft in the area of operation.

## 1.5 Surveys

1.5.1. Each craft should be subject to the surveys specified below:

- .1. an initial survey before the craft is put in service or before the certificate is issued for the first time;
- .2. a renewal survey at intervals specified by the Administration but not exceeding 5 years except where 1.8.5 or 1.8.10 is applicable;
- .3. a periodical survey within three months before or after each anniversary date of the certificate; and
- .4. an additional survey as the occasion arises.

1.5.2. The surveys referred to in 1.5.1 should be carried out as follows:

.1. the initial survey should include:

- .1.1. an appraisal of the assumptions made and limitations proposed in relation to loadings, environment, speed and manoeuvrability;
- .1.2. an appraisal of the data supporting the safety of the design obtained as appropriate from calculations, tests and trials;
- .1.3. a failure mode and effect analysis as required by this Code;
- .1.4. an investigation into the adequacy of the various manuals to be supplied to the craft; and
- .1.5. a complete inspection of the structure, safety equipment, radio installations and other equipment, fittings, arrangements and materials to ensure that they comply with the requirements of the Code, are in satisfactory condition and are fit for the service for which the craft is intended;

.2. the renewal and periodical surveys should include a complete inspection of the structure, including the outside of the craft's bottom and related items, safety equipment, radio installations and other equipment as referred to in 1.5.2.1 to ensure that they comply with the requirements of the Code, are in satisfactory condition and are fit for the service for which the craft is intended. The inspection of the craft's bottom should be conducted with the craft out of the water under suitable conditions for close-up examination of any damaged or problem areas; and

.3. an additional survey, either general or partial according to the circumstances, should be made after a repair resulting from investigations prescribed in 1.7.3, or wherever any important repairs or renewals are made. The survey should be such as to ensure that the necessary repairs or renewals have been effectively made, that the material and workmanship of such repairs or renewals are in all respects satisfactory, and that the craft complies in all respects with the requirements of the Code.



1.5.3. The periodical surveys referred to in 1.5.1.3 should be endorsed on the High Speed Craft Safety Certificate.

1.5.4. The inspection and survey of the craft, so far as regards the enforcement of the provisions of the Code, should be carried out by officers of the Administration. The Administration may, however, entrust the inspections and surveys either to surveyors nominated for the purpose or to organizations recognized by it.

1.5.5. An Administration nominating surveyors or recognizing organizations to conduct inspections and surveys as set forth in 1.5.4 should, as a minimum, empower any nominated surveyor or recognized organization to:

- .1. require repairs to a craft; and
- .2. carry out inspections and surveys if requested by the appropriate authorities of a port State.

The Administration should notify the Organization of the specific responsibilities and conditions of the authority delegated to nominated surveyors or recognized organizations.

1.5.6. When a nominated surveyor or recognized organization determines that the condition of the craft or its equipment does not correspond substantially with the particulars of the certificate or is such that the craft is not fit to operate without danger to the craft or persons on board, such surveyor or organization should immediately ensure that corrective action is taken and should, in due course, notify the Administration. If such corrective action is not taken the certificate should be withdrawn and the Administration should be notified immediately; and, if the craft is in an area under the jurisdiction of another Government, the appropriate authorities of the port State should be notified immediately. When an officer of the Administration, a nominated surveyor or recognized organization has notified the appropriate authorities of the port State, the Government of the port State concerned should give such officer, surveyor or organization any necessary assistance to carry out their obligations under this section. When applicable, the Government of the port State concerned should ensure that the craft should not continue to operate until it can do so without danger to the craft or the persons on board.

1.5.7. In every case, the Administration should fully guarantee the completeness and efficiency of the inspection and survey, and should undertake to ensure the necessary arrangements to satisfy this obligation.

## **1.6 Approvals**

. The owner of a craft should accept the obligation to supply sufficient information to enable the Administration to fully assess the features of the design. It is strongly recommended that the owner and Administration and, where appropriate, the port State or States, commence discussions at the earliest possible stage so that the Administration may fully evaluate the design in determining what additional or alternative requirements should be applied to the craft to achieve the required level of safety.

## **1.7 Maintenance of conditions after survey**

1.7.1. The condition of the craft and its equipment should be maintained to conform with the provisions of this Code to ensure that the craft in all respects will remain fit to operate without danger to the craft or the persons on board.

1.7.2. After any survey of the craft under 1.5 has been completed, no change should be made to structure, equipment, fittings, arrangements and materials covered by the survey, without the sanction of the Administration.

1.7.3. Whenever an accident occurs to a craft or a defect is discovered, either of which affects the safety of the craft or the efficiency or completeness of structure, equipment, fittings, arrangements and materials, the person in charge or owner of the craft should report at the earliest opportunity to the Administration, the nominated surveyor or recognized organization responsible, who should cause investigations to be initiated to determine whether a survey, as required by 1.5, is necessary. If the craft is in an area under the jurisdiction of another Government, the person in charge or the owner should also report immediately to the appropriate authorities of the port State and the nominated surveyor or recognized organization should ascertain that such a report has been made.

## 1.8 High Speed Craft Safety Certificate

1.8.1. A certificate called a High Speed Craft Safety Certificate is issued after completion of an initial or renewal survey to a craft which complies with the requirements of the Code. The certificate should be issued or endorsed either by the Administration or by any person or organization recognized by it. In every case, that Administration assumes full responsibility for the certificate.

1.8.2. A Contracting Government to the Convention may, at the request of the Administration, cause a craft to be surveyed and, if satisfied that the requirements of the Code are complied with, should issue or authorize the issue of a certificate to the craft and, where appropriate, endorse or authorize the endorsement of a certificate on the craft in accordance with the Code. Any certificate so issued should contain a statement to the effect that it has been issued at the request of the Government of the State the flag of which the craft is entitled to fly, and it should have the same force and receive the same recognition as a certificate issued under 1.8.1.

1.8.3. The certificate should be that of the model given in annex 1 to the Code. If the language used is neither English nor French, the text should include a translation into one of these languages.

1.8.4. The High Speed Craft Safety Certificate should be issued for a period specified by the Administration which should not exceed five years.

1.8.5. Notwithstanding the requirements of 1.8.4, when the renewal survey is completed within three months before the expiry date of the existing certificate, the new certificate should be valid from the date of completion of the renewal survey to a date not exceeding five years from the date of expiry of the existing certificate.

1.8.6. When the renewal survey is completed after the expiry date of the existing certificate, the new certificate should be valid from the date of completion of the renewal survey to a date not exceeding five years from the date of expiry of the existing certificate.

1.8.7. When the renewal survey is completed more than three months before the expiry date of the existing certificate, the new certificate should be valid from the date of completion of the renewal survey to a date not exceeding five years from the date of completion of the renewal survey.

1.8.8. If a certificate is issued for a period of less than five years, the Administration may extend the validity of the certificate beyond the expiry date to the maximum period specified in 1.8.4, provided that the surveys when a certificate is issued for a period of five years are carried out.

1.8.9. If a renewal survey has been completed and a new certificate cannot be issued or placed on board the craft before the expiry date of the existing certificate, the person or organization authorized by the Administration may endorse the existing certificate and such a certificate should be accepted as valid for a further period which should not exceed 5 months from the expiry date.

1.8.10. If a craft at the time when a certificate expires is not in the place in which it is to be surveyed, the Administration may extend the period of validity of the certificate but this extension should be granted only for the purpose of allowing the craft to proceed to the place in which it is to be surveyed, and then only in cases where it appears proper and reasonable to do so. No certificate should be extended for a period longer than one month, and a craft to which an extension is granted should not, on its arrival in the place in which it is to be surveyed, be entitled by virtue of such extension to leave that place without having a new certificate. When the renewal survey is completed, the new certificate should be valid to a date not exceeding five years from the date of expiry of the existing certificate before the extension was granted.

1.8.11. In special circumstances, as determined by the Administration, a new certificate need not be dated from the date of expiry of the existing certificate as required by 1.8.6 or 1.8.10. In these circumstances, the new certificate should be valid to a date not exceeding five years from the date of completion of the renewal survey.

1.8.12. If a periodical survey is completed before the period specified in 1.5, then:

.1. the anniversary date shown on the relevant certificate should be amended by endorsement to a date which should not be more than three months later than the date on which the survey was completed;

.2. the subsequent periodical survey required by 1.5 should be completed at the intervals prescribed by 1.5 using the new anniversary date; and

.3. the expiry date may remain unchanged provided one or more periodical surveys are carried out so that the maximum intervals between the surveys prescribed by 1.5.1.3 are not exceeded.

1.8.13. A certificate issued under 1.8.1 or 1.8.2 should cease to be valid in any of the following cases:

.1. if the relevant surveys are not completed within the periods specified in 1.5.1;

.2. if the certificate is not endorsed in accordance with 1.5.3; or

.3. upon transfer of the craft to the flag of another State. A new certificate should only be issued when the Government issuing the new certificate is fully satisfied that the craft is in compliance with the requirements of 1.7.1 and 1.7.2. In the case of a transfer between Governments that are Contracting Governments to the Convention, if requested within three months after the transfer has taken place, the Government of the State whose flag the craft was formerly entitled to fly should, as soon as possible, transmit to the Administration a copy of the certificate carried by the craft before the transfer and, if available, copies of the relevant survey reports.

1.8.14. The privileges of the Code may not be claimed in favour of any craft unless it holds a valid certificate.

## **1.9 Permit to Operate High Speed Craft**

1.9.1. The craft should not operate commercially unless a Permit to Operate High Speed Craft is issued and valid in addition to the High Speed Craft Safety Certificate. Transit voyage without passengers or cargo may be undertaken without the Permit to Operate High Speed Craft.

1.9.2. The Permit to Operate High Speed Craft should be issued by the Administration to certify compliance with 1.2.2 to 1.2.7 and stipulate conditions of the operation of the craft and drawn up on the basis of the information contained in the route operational manual specified in chapter 18 of this Code.

1.9.3. Before issuing the Permit to Operate, the Administration should consult with each port State to obtain details of any operational conditions associated with operation of the craft in that State. Any such conditions imposed should be shown by the Administration on the Permit to Operate and included in the route operational manual.

1.9.4. A port State may inspect the craft and audit its documentation for the sole purpose of verifying its compliance with the matters certified by and conditions associated with the Permit to Operate. Where deficiencies are shown by such an audit, the Permit to Operate ceases to be valid until such deficiencies are corrected or otherwise resolved.

1.9.5. The provisions of 1.8 should apply to the issue and the period of validity of the Permit to Operate High Speed Craft.

1.9.6. The Permit to Operate High Speed Craft should be that of the model given in annex 2 to this Code. If the language used is neither English nor French, the text should include a translation into one of these languages.

## **1.10 Control**

. The provisions of regulation I/19 of the Convention should be applied to include the Permit to Operate High Speed Craft in addition to the certificate issued under 1.8.

## **1.11 Equivalents**

1.11.1. Where this Code requires that a particular fitting, material, appliance or apparatus, or type thereof, should be fitted or carried in a craft, or that any particular provision should be made, the Administration may allow any other fitting, material, appliance or apparatus, or type thereof, to be fitted or carried, or any other provision to be made in that craft, if it is satisfied by trial thereof or otherwise that such fitting, material, appliance or apparatus, or type thereof, or provision, is at least as effective as that required by this Code.

1.11.2. Where compliance with any of the requirements of this Code would be impractical for the particular designs of the craft, the Administration may substitute those with alternative requirements provided that equivalent safety is achieved. The Administration which allows any such substitution should communicate to the

Organization particulars of these substitutions and the reasons therefore, which the Organization should circulate to its Member Governments for their information.

## **1.12 Information to be made available**

1.12.1. The Administration should ensure that the management of the company operating the craft has provided the craft with adequate information and guidance in the form of manuals to enable the craft to be operated and maintained safely. These manuals should include a route operational manual, craft operating manual, maintenance manual and servicing schedule. Such information should be updated as necessary.

1.12.2. The manuals should contain at least the information specified in chapter 18 and should be in a language understood by the crew. Where this language is not English, a translation into English should be provided of at least the route operational manual and the craft operating manual.

## **1.13 Further developments**

1.13.1. It is recognized that there is much ongoing research and development in the design of high speed craft and that new types may emerge which have different geometry to that envisaged during the formulation of this Code. It is important that this Code does not restrict this progress and the development of new designs.

1.13.2. A design may be produced which cannot comply with the provisions of this Code. In such a case the Administration should determine the extent to which the provisions of the Code are applicable to the design and, if necessary, develop additional or alternative requirements to provide an equivalent level of safety for the craft.

1.13.3. The foregoing should be considered by the Administration when assessing the granting of equivalents under the Code.

## **1.14 Circulation of safety information**

1.14.1. In the event that an Administration has cause to investigate an accident involving a craft to which this Code applies, that Administration should provide a copy of the official report to the Organization, which will invite Member States to note the existence of the report and to obtain a copy.

1.14.2. In the event that operational experience reveals structural or equipment failures affecting the safety of a design, craft owners should inform the Administration.

## **1.15 Review of the Code**

1.15.1. The Code should be reviewed by the Organization at intervals preferably not exceeding four years to consider revision of existing requirements to take account of new developments in design and technology.

1.15.2. Where a new development in design and technology has been found acceptable to an Administration, that Administration may submit particulars of such development to the Organization for consideration for incorporation into the Code during periodical review.

# **Chapter 2 - Buoyancy, Stability and Subdivision**

## **Part A - General**

### **2.1 General**

2.1.1. A craft should be provided with:

.1. stability characteristics and stabilization systems adequate for safety when the craft is operated in the non-displacement mode and during the transient mode;

.2. buoyancy and stability characteristics adequate for safety where the craft is operated in the displacement mode, both in the intact condition and the damaged condition; and

.3. stability characteristics in the non-displacement and transient modes adequate to transfer the craft safely to displacement mode in case of any system malfunction.

2.1.2. Account should be taken of the effect of icing in the stability calculations. An example for established practice for ice accretion allowances is given in annex 5 for the guidance of Administrations.

2.1.3. For the purpose of this and other chapters, unless expressly defined otherwise, the following definitions apply:

.1. "Down flooding point" means any opening through which flooding of the spaces which comprise the reserve buoyancy could take place while the craft is in the intact or damaged condition, and heels to an angle past the angle of equilibrium.

.2. "Fully submerged foil" means a foil having no lift components piercing the surface of the water in the foil borne mode.

.3. "Multihull craft" means a craft which in any normally achievable operating trim or heel angle, has a rigid hull structure which penetrates the surface of the sea over more than one discrete area.

.4. "Permeability" of a space means the percentage of the volume of that space which can be occupied by water.

.5. "Skirt" means a downwardly-extending, flexible structure used to contain or divide an air cushion.

.6. "Watertight" in relation to a structure means capable of preventing the passage of water through the structure in any direction under the head of water likely to occur in the intact or damaged condition.

.7. "Weathertight" means that water will not penetrate into the craft in any wind and wave conditions up to those specified as critical design conditions.

## **2.2 Intact buoyancy**

2.2.1. All craft should have a sufficient reserve of buoyancy at the design waterline to meet the intact and damage stability requirements of this chapter. The Administration may require a larger reserve of buoyancy to permit the craft to operate in any of its intended modes. This reserve of buoyancy should be calculated by including only those compartments which are:

.1. watertight;

.2. accepted as having scantlings and arrangements adequate to maintain their watertight integrity; and

.3. situated in locations below a datum, which may be a watertight deck or equivalent structure of a non-watertight deck covered by a weathertight structure as defined in 2.2.3.1.

2.2.2. Arrangements should be provided for checking the watertight integrity of those compartments taken into account in 2.2.1.

2.2.3. Where entry of water into structures above the datum as defined in 2.2.1.3 would significantly influence the stability and buoyancy of the craft, such structures should be:

.1. of adequate strength to maintain the weathertight integrity and fitted with weathertight closing appliances; or

.2. provided with adequate drainage arrangements; or

.3. an equivalent combination of both measures.

2.2.4. The means of closing openings in the boundaries of weathertight structures should be such as to maintain weathertight integrity in all operational conditions.

## **2.3 Intact stability in the displacement mode**

2.3.1. Hydrofoil craft fitted with surface-piercing foils and/or fully submerged foils should have sufficient stability under all permitted cases of loading to comply with the relevant provisions of annex 6 and specifically maintain a heel angle of less than 10° when subjected to the greater of the heeling moments in 1.1.2 and 1.1.4 of that annex.

2.3.2. Multihull craft should meet the relevant requirements of annex 7 for all permitted cases of loading.

2.3.3. Subject to 2.3.4, all other craft should meet the following criteria in all permitted conditions of loading:

.1. resolution A.562(14) (weather criterion);

.2. the area under the righting lever curve (GZ curve) should not be less than 0.07 m.rad up to  $\theta = 15^\circ$  when the maximum righting lever (GZ) occurs at  $\theta = 15^\circ$  and 0.055 m.rad up to  $\theta = 30^\circ$  when the maximum righting lever occurs at  $\theta = 30^\circ$  or above. Where the maximum righting lever occurs at angles of between  $\theta = 15^\circ$  and  $\theta = 30^\circ$  the corresponding area under the righting lever curve should be:

$$A = 0.055 + 0.001 (30^\circ - \theta_{\max}) \text{ (m.rad)}$$

where:

$\theta_{\max}$  is the angle of heel in degrees at which the righting lever curve reaches its maximum;

.3. the area under the righting lever curve between  $\theta = 30^\circ$  and  $\theta = 40^\circ$  or between  $\theta = 30^\circ$  and the angle of flooding  $\theta$ , if this angle is less than 40°, should not be less than 0.03 m.rad;

.4. the righting lever GZ should be at least 0.20 m at an angle of heel equal to or greater than 30°;

.5. the maximum righting lever should occur at an angle of heel not less than 15°; and

.6. the initial metacentric height  $GM_0$  should not be less than 0.15 m.

2.3.4. Where the characteristics of the craft are unsuitable for application of 2.3.3, the Administration may accept alternative criteria equivalent to those stipulated in 2.3.3, appropriate to the type of craft and area of operation.

## 2.4 Intact stability in the non-displacement mode

2.4.1. The requirements of this section and section 2.12 should be applied on the assumption that any stabilization systems fitted are fully operational.

2.4.2. Suitable calculations should be carried out and/or tests conducted to demonstrate that, when operating in the non-displacement and transient modes within approved operational limitations, the craft will, after a disturbance causing roll, pitch, heave or heel due to turning or any combination thereof, return to the original attitude.

2.4.3. The roll and pitch stability on the first and/or any other craft of a series should be qualitatively assessed during operational safety trials as required by chapter 18 and annex 8. The results of such trials may indicate the need to impose operational limitations.

2.4.4. Where craft are fitted with surface piercing structure or appendages, precautions should be taken against dangerous attitudes or inclinations and loss of stability subsequent to a collision with a submerged or floating object.

2.4.5. In designs where periodic use of cushion deformation is employed as a means of assisting craft control, or periodic use of cushion air exhausting to atmosphere for purposes of craft manoeuvring, the effects upon cushion-borne stability should be determined, and the limitations on the use by virtue of craft speed or attitude should be established.

2.4.6. In the case of an air-cushion vehicle fitted with flexible skirts, it should be demonstrated that the skirts remain stable under operational conditions.

## 2.5 Intact stability in the transient mode

2.5.1. Under weather conditions up to the worst intended conditions, the time to pass from the displacement mode to the non-displacement mode and vice versa should be minimized unless it is demonstrated that no substantial reduction of stability occurs during this transition.

2.5.2. Hydrofoil craft should comply with the relevant provisions of annex 6.

## 2.6 Buoyancy and stability in the displacement mode following damage

2.6.1. The requirements of this section apply to all permitted conditions of loading.

2.6.2. For the purpose of making damage stability calculations the volume and surface permeabilities should be in general as follows:

Spaces	Permeability
Appropriated to cargo or stores	60
Occupied by accommodation	95
Occupied by machinery	85
Intended for liquids	0 or 95*
Appropriated for cargo vehicles	90
Void spaces	95

\* whichever results in the more severe requirements

2.6.3. Notwithstanding 2.6.2, permeability determined by direct calculation should be used where a more onerous condition results, and may be used where a less onerous condition results from that provided according to 2.6.2.

2.6.4. Administrations may permit the use of low density foam or other media to provide buoyancy in void spaces, provided that satisfactory evidence is provided that any such proposed medium is the most suitable alternative and is:

- .1. of closed cell form if foam, or otherwise impervious to water absorption;
- .2. structurally stable under service conditions;
- .3. chemically inert in relation to structural materials with which it is in contact or other substances with which the medium is likely to be in contact (reference is made to 7.4.3.7): and
- .4. properly secured in place and easily removable for inspection of the void spaces.

2.6.5. Any damage of a lesser extent than that postulated in 2.6.6 to 2.6.8, as applicable, which would result in a more severe condition, should also be investigated. The shape of the damage should be assumed to be a parallelepiped.

2.6.6. The following side damages should be assumed anywhere on the periphery of the craft:

- .1. the longitudinal extent of damage should be  $0.1L$ , or  $3\text{ m} + 0.03L$  or  $11\text{ m}$ , whichever is the least;
- .2. the transverse extent of penetration into the craft should be  $0.2B$  or  $0.05L$  or  $5\text{ m}$ , whichever is the least. However, where the craft is fitted with inflated skirts or with non-buoyant side structures, the transverse extent of penetration should be at least  $0.12$  of the width of the main buoyancy hull or tank structure; and
- .3. the vertical extent of damage should be taken for the full depth of the craft.

2.6.7. Subject to 2.6.8, bottom damages should be assumed anywhere on the bottom of the craft as follows:

- .1. the longitudinal extent of damage should be  $0.1L$  or  $3\text{ m} + 0.03L$  or  $11\text{ m}$ , whichever is the least;
- .2. the transverse extent of damage should be the full breadth of the bottom of the craft or  $7\text{ m}$ , whichever is the less, as shown in figure 2.6.7.2; and
- .3. the vertical extent of penetration into the craft should be  $0.02B$  or  $0.5\text{ m}$ , whichever is the less.

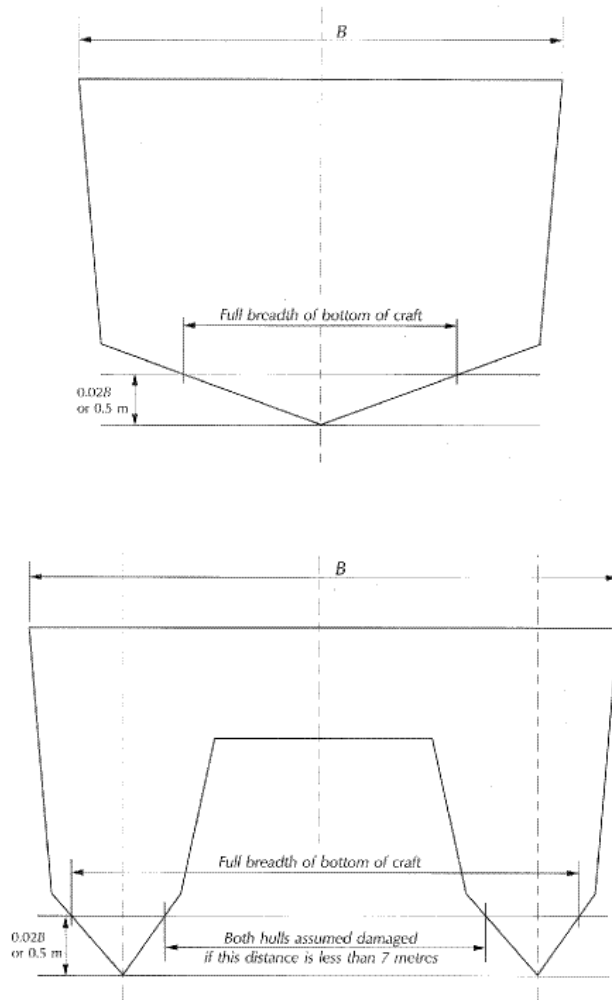

**Figure 2.6.7.2**

2.6.8. In the case of a category B craft, the length of the assumed damage specified in 2.6.7 should be increased by 50% in the case of damage in the forward  $0.5L$  of the craft.

## 2.7 Inclining and stability information

2.7.1. Every craft on completion of build should be inclined and the elements of its stability determined. When an accurate inclining is not practical the lightship displacement and centre of gravity should be determined by a lightweight survey and accurate calculation.

2.7.2. The master should be supplied by the owner with reliable information relating to the stability of the craft in accordance with the following provisions of this paragraph. The information relating to stability should, before issue to the master, be submitted to the Administration for approval, together with a copy thereof for their retention and should incorporate such additions and amendments as the Administration may in any particular case require.



2.7.3. Where any alterations are made to a craft so as materially to affect the stability information supplied to the master, amended stability information should be provided. If necessary, the craft should be re-inclined.

2.7.4. A report of each inclining or lightweight survey carried out in accordance with this chapter and of the calculation therefrom of the lightship condition particulars should be submitted to the Administration for approval, together with a copy for their retention. The approved report should be placed on board the craft by the owner in the custody of the master and should incorporate such additions and amendments as the Administration may in any particular case require. The amended lightship condition particulars so obtained from time to time should be used by the master in substitution for such previously approved particulars when calculating the craft's stability.

2.7.5. Following any inclining or lightweight survey the master should be supplied with amended stability information if the Administration so requires. The information so supplied should be submitted to the Administration for approval, together with a copy thereof for their retention and should incorporate such additions and amendments as the Administration may in any particular case require.

2.7.6. Stability information demonstrating compliance with this chapter should be furnished in the form of a stability information book which should be kept on board the craft at all times in the custody of the master. The information should include particulars appropriate to the craft and should reflect the craft's loading conditions and mode of operation. Any enclosed superstructures or deckhouses included in the cross curves of stability and the critical downflooding points and angles should be identified.

2.7.7. Every craft should have scales of draughts marked clearly at the bow and stern. In the case where the draught marks are not located where they are easily readable, or operational constraints for a particular trade make it difficult to read the draught marks, then the craft should also be fitted with a reliable draught indicating system by which the bow and stern draughts can be determined.

2.7.8. The owner or builder as appropriate should ensure that the positions of the draught marks are accurately determined and that the marks are located on the hull in a permanent manner. Accuracy of the draught marks should be demonstrated to the Administration prior to the inclining experiment.

## **2.8 Loading and stability assessment**

. On completion of loading of the craft and prior to its departure on a voyage, the master should determine the craft's trim and stability and also ascertain and record that the craft is in compliance with stability criteria of the relevant requirements. The Administration may accept the use of an electronic loading and stability computer or equivalent means for this purpose.

## **2.9 Marking and recording of the design waterline**

. The design waterline should clearly be marked amidships on the craft's outer sides and should be recorded in the high Speed Craft Safety Certificate. This waterline should be distinguished by the notation H.

# **Part B - Requirements for Passenger Craft**

## **2.10 General**

. Where compliance with this chapter requires consideration of the effects of passenger weight, the following information should be used:

- .1. The distribution of passengers is 4 persons per square metre.
- .2. Each passenger has a mass of 75 kg.
- .3. Vertical centre of gravity of seated passengers is 0.3 m above seat.
- .4. Vertical centre of gravity of standing passengers is 1.0 m above deck.
- .5. Passengers and luggage should be considered to be in the space normally at their disposal.
- .6. Passengers should be distributed on available deck areas towards one side of the craft on the decks where muster stations are located and in such a way that they produce the most adverse heeling moment.

## 2.11 Intact stability in the displacement mode

. The craft should have sufficient intact stability that, when in still water conditions, the inclination of the craft from the horizontal would not exceed 10° under all permitted cases of loading and uncontrolled passenger movements as may occur.

## 2.12 Intact stability in the non-displacement mode

2.12.1. The total heel angle in still water due to the effect of passenger movements and due to beam wind pressure as per 1.1.4 of annex 6 should not exceed 10°.

2.12.2. In all loading conditions, the outward heel due to turning should not exceed 8°, and the total heel due to beam wind pressure as per 1.1.4 of annex 6 and due to turning should not exceed 12° outward.

## 2.13 Buoyancy and stability in the displacement mode following damage

. Following any of the postulated damages detailed in 2.6.5 to 2.6.8, the craft in still water should have sufficient buoyancy and positive stability to simultaneously ensure that:

.1. after flooding has ceased and a state of equilibrium has been reached, the final waterline be 300 mm below the level of any opening through which further flooding could take place;

.2. the angle of inclination of the craft from the horizontal does not normally exceed 10° in any direction. However, where this is clearly impractical, angles of inclination up to 15° immediately after damage but reducing to 10° within 15 min may be permitted provided that efficient non-slip deck surfaces and suitable holding points, e.g., holes, bars, etc., are provided;

.3. there is a positive freeboard from the damage waterline to survival craft embarkation positions;

.4. any flooding of passenger compartments or escape routes which might occur will not significantly impede the evacuation of passengers;

.5. essential emergency equipment, emergency radios, power supplies and public address systems needed for organizing the evacuation remain accessible and operational;

.6. the residual stability of multihull craft complies with the appropriate criteria as laid out in annex 7; and

.7. residual stability of any other craft meets the requirements of regulation II-1/8 of the Convention.

## 2.14 Inclining and stability information

2.14.1. At periodical intervals not exceeding five years, a lightweight survey should be carried out on all passenger craft to verify any changes in lightweight displacement and longitudinal centre of gravity. The passenger craft should be re-inclined whenever, in comparison with the approved stability information, a deviation from the lightweight displacement exceeding 2% or a deviation of the longitudinal centre of gravity exceeding 1% of L is found or anticipated.

2.14.2. A report of each inclining or lightweight survey carried out in accordance with 2.7.1 and of the calculation therefrom of the lightweight condition particulars should be submitted to the Administration for approval, together with a copy for their retention. The approved report should be placed on board the craft by the owner in the custody of the master and should incorporate such additions and amendments as the Administration may in any particular case require. The amended lightweight condition particulars so obtained from time to time should be used by the master in substitution for such previously approved particulars when calculating the craft's stability.

2.14.3. Following any inclining or lightweight survey the master should be supplied with amended stability information if the Administration so requires. The information so supplied should be submitted to the Administration for approval, together with a copy thereof for their retention and should incorporate such additions and amendments as the Administration may in any particular case require.

## **Part C - Requirements for Cargo Craft**

### **2.15 Buoyancy and stability in the displacement mode following damage**

. Following any of the postulated damages detailed in 2.6.5 to 2.6.7, the craft in still water should have sufficient buoyancy and positive stability to simultaneously ensure that:

.1. after flooding has ceased and a state of equilibrium has been reached the final waterline is 150 mm below the level of any opening through which further flooding could take place;

.2. the angle of inclination of the craft from the horizontal does not normally exceed 15° in any direction. However, where this is clearly impractical, angles of inclination up to 20° immediately after damage but reducing to 15° within 15 min may be permitted provided that efficient non-slip deck surfaces and suitable holding points, e.g., holes, bars, etc., are provided;

.3. there is a positive freeboard from the damage waterline to survival craft embarkation positions;

.4. essential emergency equipment, emergency radios, power supplies and public address systems needed for organizing the evacuation remain accessible and operational;

.5. the residual stability of multihull craft complies with the appropriate criteria as laid out in annex 7; and

.6. the residual stability of any other craft meets the requirements of regulation II-1/8 of the Convention.

### **2.16 Inclining**

. Where it is satisfied by lightweight survey, weighing or other demonstration, that the lightweight of a craft is closely similar to that of another craft of the series to which 2.7.1 has been applied, the Administration may waive the requirement of 2.7.1 for craft to be inclined. In this regard, a craft which lies within the parameters of 2.14.1, when compared with a craft of the series which has been inclined, should be regarded as being closely similar to that craft.

## **Chapter 3 – Structures**

### **3.1 General**

. This chapter covers those elements of hull and superstructure which provide longitudinal and other primary and local strength of the craft as a whole and also other important components such as foils and skirts which are directly associated with the hull and superstructure.

### **3.2 Materials**

. Materials used for the hull and superstructure and the other features referred to in 3.1 should be adequate for the intended use of the craft.

### **3.3 Structural strength**

. The structure should be capable of withstanding the static and dynamic loads which can act on the craft under all operating conditions in which the craft is permitted to operate, without such loading resulting in inadmissible deformation and loss of watertightness or interfering with the safe operation of the craft.

### **3.4 Cyclic loads**

. Cyclic loads, including those from vibrations which can occur on the craft should not:

- .1. impair the integrity of structure during the anticipated service life of the craft or the service life agreed with the Administration;
- .2. hinder normal functioning of machinery and equipment; and
- .3. impair the ability of the crew to carry out its duties.

## **3.5 Design criteria**

. The Administration should be satisfied that the choice of design conditions, design loads and accepted safety factors corresponds to the intended operating conditions for which certification is sought.

## **3.6 Trials**

. If the Administration consider it necessary, it should require full-scale trials to be undertaken in which loadings are determined. Cognizance should be taken of the results where these indicate that loading assumptions of structural calculations have been inadequate.

# **Chapter 4 - Accommodation and Escape Measures**

## **4.1 General**

4.1.1. Passenger and crew accommodation should be designed and arranged so as to protect the occupants from unfavourable environmental conditions and to minimize the risk of injury to occupants during normal and emergency conditions.

4.1.2. Spaces accessible to passengers should not contain controls, electrical equipment, high temperature parts and pipelines, rotating assemblies or other items, from which injury to passengers could result, unless such items are adequately shielded, isolated, or otherwise protected.

4.1.3. Passenger accommodation should not contain operating controls unless the operating controls are so protected and located that their operation by a crew member should not be impeded by passengers during normal and emergency conditions.

4.1.4. Windows in passenger and crew accommodation should be of adequate strength and suitable for the worst intended conditions specified in the Permit to Operate and be made of material which will not break into dangerous fragments if fractured.

4.1.5. The public spaces, crew accommodation and the equipment therein should be designed so that each person making proper use of these facilities will not suffer injury during craft's normal and emergency start, stop and manoeuvring in normal cruise and in failure or maloperation conditions.

## **4.2 Public address and information system**

4.2.1. A general emergency alarm system should be provided. The alarm should be audible throughout all the accommodation and normal crew working spaces and open decks, and the sound pressure level should be at least 10 dB(A) above ambient noise levels underway in normal cruise operation. The alarm should continue to function after it has been triggered until it is normally turned off or is temporarily interrupted by a message on the public address system.

4.2.2. There should be a public address system covering all areas where passengers and crew have access, escape routes, and places of embarkation into survival craft. The system should be such that flooding or fire in any compartment does not render other parts of the system inoperable.

4.2.3. All passenger craft should be equipped with illuminated or luminous notices or video information system(s) visible to all sitting passengers, in order to notify them of safety measures.

4.2.4. The master should, by means of 4.2.3, be able to request passengers "please be seated" when he finds this appropriate to safeguard passengers and always when the safety level 2 according to table 1 of annex 3, is exceeded.

4.2.5. Emergency instructions including a general diagram of the craft showing the location of all exits, routes of evacuation, emergency equipment, life-saving equipment and illustration of lifejacket donning should be available to each passenger and placed near each passenger's seat.

### 4.3 Design acceleration levels

4.3.1. For passenger craft, superimposed vertical accelerations above 1.0 g at longitudinal centre of gravity should be avoided unless special precautions are taken with respect to passenger safety.

4.3.2. Passenger craft should be designed for the collision load with respect to the safety in, and escape from, the public spaces, crew accommodation and escape routes, including in way of life-saving appliances and emergency source of power. The size and type of craft together with speed, displacement and building material should be taken into consideration when the collision load is determined. The collision design condition should be based on head-on collision at operational speed with a vertical rock with maximum 2 m height above the waterline.

4.3.3. Taking into consideration the provisions of 4.3.2, the collision load should be determined by:

$$g_{coll} = 1.2 \left( \frac{P}{g \cdot \Delta} \right)$$

where the load P should be taken as the lesser of:

$$P = 460 (M \cdot c_L)(E \cdot C_H) \text{ and}$$

$$P = 9000 \cdot M \cdot c_L (C_H(T+2))^{1/2}$$

where the hull material factor M should be taken as:

M = 1.3 for high tensile steel

M = 1.00 for aluminium alloy

M = 0.95 for mild steel

M = 0.8 for fibre reinforced plastics

where the length factor  $c_L$  of the craft is:

$$c_L = \frac{(165 + L)}{245} \left( \frac{L}{80} \right)^{0.4}$$

where the height factor  $c_H$  of the craft is:

Factor $c_H$	Catamaran/surface effect ship	Monohull/hydrofoil	Air-cushion vehicle
$c_H$	$\frac{T + 2 + f(D/2)}{2D}$	$\frac{T + 2 + f(D/2)}{2D}$	$\frac{f}{4}$
where: f=0 for	$T + 2 < D - H_T$	$T + 2 < D$	-
where: f=1 for	$D > T + 2 \geq D - H_T$	$T + 2 \geq D$	$H_T > 2$
where: f=2 for	$T + 2 \geq D$	-	$H_T$

where the kinetic energy of the craft at speed V is:

$$E = \frac{1}{2} \Delta \cdot V^2 \text{ (KN m)}$$

where the main particulars of the craft are:

L = craft length as defined in chapter 1 (m)

D = craft depth from the underside of keel amidships to the top of the effective hull girder (m)

T = buoyancy tank clearance to skirt tip (m, (negative)) for air-cushion vehicles; lifted clearance from keel to water surface (m, (negative)) for hydrofoils, and craft draught to the underside of keel amidships for all other craft (m)

H<sub>T</sub> = minimum height from tunnel or wet-deck bottom to the top of the effective hull girder on catamarans and surface effect ships and D for air-cushion vehicle (m)

Δ = craft displacement, being the mean of the lightweight and maximum operational weight (t)

v = operational speed of craft (m/s)

g = gravitational acceleration = 9.806 (m/s<sup>2</sup>)

For hydrofoils, if the result is greater than the deceleration, g<sub>coll</sub> should be taken as:

$$g_{coll} = \frac{F}{g \cdot \Delta}$$

where:

F = failure load of bow foil assembly applied at the operational waterline (kN)

4.3.4. As an alternative to the requirements of 4.3.3, collision deceleration may be determined by carrying out collision load analysis of the craft in 4.3.3 accordance with the assumptions of 4.3.2. If the collision accelerations are determined by both use of the formula referred to in and the collision load analysis, the lower resulting value may be used as the collision deceleration.

4.3.5. Compliance with the provisions of 4.1.5 and 4.3.1 should be shown for the actual type of craft, as described in annex 8.

4.3.6. Limiting sea states for operation of the craft should be given in normal operation condition and in the worst intended conditions, at operational speed and at reduced speed as necessary. Operational information should be available on board for guidance, or the craft should have an instrument system for on-line check of operational performance. As a minimum, the system should measure accelerations in three axes close to the longitudinal craft centre of gravity.

## 4.4 Accommodation design

4.4.1. The public spaces and crew accommodation of high speed craft should be located and designed to protect passengers and crew under the collision design condition. In this respect, these spaces should not be located within a distance of:

$$\frac{V^2}{20 \cdot g_{coll}}$$

of the extreme forward end of the top of the effective hull girder of the craft, where the terms V and g<sub>coll</sub> are as defined in 4.3.3. For this purpose g<sub>coll</sub> need not be taken as less than 3, and should not be taken as greater than 12.

4.4.2. The accommodation should be designed according to the guidelines given in table 4.4.2 and to performance requirements given in annex 9, or by other methods which have been proven to give equal protective qualities.

**Tab 4.4.2 Overview general design guidelines**

Design Level 1: g <sub>coll</sub> less than 3	
1	Seat/seat belts
1.1	Low or high seatback
1.2	No restrictions on seating
1.3	Sofas allowed

- 1.4 No seat belts requirement
- 2 Tables in general allowed
- 3 Padding of projecting objects
- 4 Kiosks, bars, etc., no special restrictions
- 5 Baggage, no special requirements
- 6 large masses, restraintment

Design level 2:  $g_{coll}$  3 to 12

- 1 Seat/seat belts
  - 1.1 High seatback with protective deformation and padding
  - 1.2 Forward or backward seating direction
  - 1.3 No sofas allowed as seat
  - 1.4 Lap belt in seats when no protective structure forward
- 2 Tables with protective features allowed. Dynamic testing

- 3 Padding of projecting objects
- 4 Kiosk , bars , etc., on aft side of bulkheads, or other specially approved arrangments
- 5 Baggage placed with protection forward
- 6 Large masses, restraintment and positioning

Design Level 3:  $g_{coll}$  above 13

- 1 Seat/seat belts
  - 1.1 High seatback with protective deformation and padding
  - 1.2 Forward or backward seating direction
  - 1.3 No sofas allowed as seat
  - 1.4 Seat belt necessary to obtain required protection
    - No belts in backwards facing seats
    - 3 point belt or belt with shoulder harness in forward facing seats
- 2 No tables allowed
- 3 Padding of protecting objects, specially approved
- 4 Kiosk, bars, etc ., specially approved
- 5 Baggage placedwith protection forward, specially approved
- 6 Large masses restraintment and positioning, speacially approved

\* Other arrangements may be employed if an equivalent level safety is acheived

4.4.3. Equipment and baggage in public spaces and in the operator's compartment should be positioned and secured so that they remain in the stowed position when exposed to the collision design acceleration according to 4.3.3 and 4.3.4.

4.4.4. Mountings of large masses such as main engines, auxiliary engines, lift fans, transmissions and electrical equipment should be proved by calculations to withstand the collision design acceleration according to 4.3.3 and 4.3.4 without fracturing.

4.4.5. Seats, life-saving appliances and items of substantial mass and their supporting structure should not deform or dislodge under any loads up to those specified in 4.3.3 and 4.3.4 in any manner that would impede subsequent rapid evacuation of passengers.

4.4.6. There should be adequate handholds on both sides of any passage to enable passengers to steady themselves while moving about.

## 4.5 Seating construction

4.5.1. A seat should be provided for each passenger and crew member for which the craft is certified to carry.

4.5.2. Seats fitted in addition to those required under 4.5.1 and which are not permitted to be used in hazardous navigational situations or potentially dangerous weather or sea conditions, need not comply with 4.5 or 4.6. Such seats should be secured according to 4.4.5 and clearly identified as not being able to be used in hazardous situations.

4.5.3. The installation of seats should be such as to allow adequate access to any part of the accommodation space. In particular, they should not obstruct access to, or use of, any essential emergency equipment or means of escape.

4.5.4. Seats and their attachments, and the structure in the proximity of the seats, should be of a form and design, and so arranged, such as to minimize the possibility of injury and to avoid trapping of the passengers after the assumed damage in the collision design condition according to 4.4.1. Dangerous projections and hard edges should be eliminated or padded.

4.5.5. Seat, seat belts, seat arrangement and adjacent parts such as tables should be designed for the actual collision design acceleration as specified in 4.3.3.

4.5.6. All seats, their supports and their deck attachments should have good energy absorbing characteristics and should meet the requirements of annex 9.

## 4.6 Safety belts

4.6.1. One-hand-release safety belts of 3 point type or with shoulder harness should be provided for all seats from which the craft may be operated for all craft with the  $g_{coll}$  acceleration from the collision design acceleration exceeding 3g, as prescribed in 4.3.3.

4.6.2. Safety belts should be provided on passenger seats and crew seats, if necessary, to obtain the protective performance measures described in annex 9.

## 4.7 Exits and means of escape

4.7.1. For the same reason, easy, safe and quick access from the operating compartment to the passenger accommodation should be provided. In order to ensure immediate assistance from the crew in an emergency situation, the crew accommodation, including any cabins, should be located with due regard to easy, safe and quick access to the public spaces from inside the craft.

4.7.2. The design of the craft should be such that all occupants may safely evacuate the craft into survival craft under all emergency conditions, by day or by night. The positions of all exits which may be used in an emergency, and of all life-saving appliances, the practicability of the evacuation procedure, and the evacuation time to evacuate all passengers and crew should be demonstrated.



4.7.3. Public spaces, evacuation routes, exits, lifejacket stowage, survival craft stowage, and the embarkation stations should be clearly and permanently marked and illuminated as required in chapter 12.

4.7.4. Each enclosed public space and similar permanently enclosed space allocated to passengers or crew should be provided with at least two exits arranged in the opposite ends of the space. Exits should be safely accessible and should provide a route to a normal point of boarding or disembarking from the craft.

4.7.5. Subdivision of public spaces to provide refuge in case of fire may be required in compliance with 7.4.4.1 and b7.11.1.

4.7.6. Exit doors should be capable of being readily operated from inside and outside the craft in daylight and in darkness. The means of operation should be obvious, rapid and of adequate strength.

4.7.7. The closing, latching and locking arrangements for exits should be such that it is readily apparent to the appropriate crew member when the doors are closed and in a safe operational condition, either in direct view or by an indicator. The design of external doors should be such to eliminate the possibility of jamming by ice or debris.

4.7.8. The craft should have a sufficient number of exits which are suitable to facilitate the quick and unimpeded escape of persons wearing approved lifejackets in emergency conditions, such as collision damage or fire.

4.7.9. Sufficient space for a crew member should be provided adjacent to exits for ensuring the rapid evacuation of passengers.

4.7.10. All exits, together with their means of opening, should be adequately marked for the guidance of passengers. Adequate marking should also be provided for the guidance of rescue personnel outside the craft.

4.7.11. Footholds, ladders, etc., provided to give access from the inside to exits, should be of rigid construction and permanently fixed in position. Permanent handholds should be provided whenever necessary to assist persons using exits, and should be suitable for conditions when the craft has developed any possible angles of list or trim.

4.7.12. At least two unobstructed evacuation paths should be available for the use of each person. Evacuation paths should be disposed such that adequate evacuation facilities will be available in the event of any likely damage or emergency conditions, and evacuation paths should have adequate lighting supplied from the main and emergency sources of power.

4.7.13. The dimensions of passages, doorways and stairways which form part of evacuation paths should be such as to allow easy movement of persons when wearing lifejackets. There should be no protrusions in evacuation paths which could cause injury, ensnare clothing, damage lifejackets or restrict evacuation of disabled persons.

4.7.14. Adequate notices should be provided to direct passengers to exits.

4.7.15. Provision should be made on board for embarkation stations to be properly equipped for evacuation of passengers into life-saving appliances. Such provision should include handholds, anti-skid treatment of the embarkation deck, and adequate space which is clear of cleats, bollards and similar fittings.

## 4.8 Evacuation time

4.8.1. The provisions for evacuation should be designed such that the craft can be evacuated under controlled conditions in a time of one third of the structural fire protection time (SFP) provided in 7.4.2 for major fire hazard areas after subtracting a period of 7 min for initial detection and extinguishing action.

$$\text{Evacuation Time} = \frac{(SFP - 7)}{3} \text{ (min)}$$

where:

SFP = structural fire protection time (min)

4.8.2. An evacuation procedure, including a critical path analysis, should be developed for the information of the Administration in connection with the approval of fire insulation plans and for assisting the owners and builders in planning the evacuation demonstration required in 4.8.3.

The evacuation procedures should include:

- .1. the emergency announcement made by the master;
- .2. contact with base port;
- .3. the donning of lifejackets;
- .4. manning of survival craft and emergency stations;
- .5. the shutting down of machinery and oil fuel supply lines;
- .6. the order to evacuate;
- .7. the deployment of survival craft and marine escape systems and rescue boats;
- .8. the bowing in of survival craft;
- .9. the supervision of passengers;
- .10. the orderly evacuation of passengers under supervision;
- .11. crew checking that all passengers have left the craft;
- .12. the evacuation of crew;
- .13. releasing the survival craft from the craft; and
- .14. the marshalling of survival craft by the rescue boat where provided.

4.8.3. Achievement of the required evacuation time (as ascertained in accordance with 4.8.1) should be verified by a practical demonstration conducted under controlled conditions in the presence of the Administration, and should be fully documented and verified for passenger craft by the Administration.

4.8.4. Evacuation demonstrations should be carried out with due concern for the problems of mass movement or panic acceleration likely to arise in an emergency situation when rapid evacuation is necessary. The evacuation demonstrations should be dry shod with the survival craft initially in their stowed positions and be conducted as follows:

- .1. The evacuation time on a category A craft should be the time elapsed from the moment the first abandon craft announcement is given, with any passengers distributed in a normal voyage configuration, until the last person has embarked in a survival craft, and should include the time for passengers and crew to don lifejackets.
- .2. The evacuation time on a category B craft and cargo craft should be the time elapsed from the moment the order to abandon the craft is given, until the last person has embarked in a survival craft. Passengers and crew may be wearing lifejackets and prepared for evacuation, and they may be distributed among muster stations.
- .3. For all craft the evacuation time should include the time necessary to launch, inflate and secure the survival craft alongside ready for embarkation.

4.8.5. The evacuation time should be verified by an evacuation demonstration which should be performed using the survival craft and exits on one side, for which the critical path analysis indicates the greatest evacuation time, with the passengers and crew allocated to them.

4.8.6. On craft where a half trial is impracticable, the Administration may consider a partial evacuation trial using a route which the critical path analysis shows to be the most critical.

4.8.7. The demonstration should be carried out in controlled conditions in the following manner in compliance with the evacuation plan.

.1. The demonstration should commence with the craft afloat in harbour, in reasonably calm conditions, with all machinery and equipment operating in the normal seagoing condition.

.2. All exits and doors inside the craft should be in the same position as they are under normal seagoing condition.

.3. Safety belts, if required, should be fastened.

.4. The evacuation routes for all passengers and crew should be such that no person need enter the water during the evacuation.

4.8.8. For passenger craft, a representative composition of persons with normal health, height and weight should be used in the demonstration, and should consist of different sexes and ages so far as it is practicable and reasonable.

4.8.9. The persons, other than the crew selected for the demonstration, should not have been specially drilled for such a demonstration.

4.8.10. An emergency evacuation demonstration should be carried out for all new designs of high speed craft and for other craft where evacuation arrangements differ substantially from those previously tested.

4.8.11. The specific evacuation procedure followed during the craft's initial demonstration on which certification is based should be included in the craft operating manual together with the other evacuation procedures contained in 4.8.2. During the demonstration video recordings should be made both inside and outside the craft which should form an integral part of the training manual required by 18.2.

## **4.9 Baggage, stores, shops and cargo compartments**

4.9.1. Provision should be made to prevent shifting of baggage, stores and cargo compartment contents, having due regard to occupied compartments and accelerations likely to arise. If safeguarding by positioning is not practicable, adequate means of restraint for baggage, stores and cargo should be provided. Shelves and overhead shelves for storage of carry-on baggage in passenger accommodation should be provided with adequate means to prevent the luggage from falling out in any conditions that may occur.

4.9.2. Controls, electric equipment, high temperature parts, pipelines or other items, the damage or failure of which could affect the safe operation of the craft or which may require access by crew members during a voyage, should not be located in baggage, store and cargo compartments unless such items are adequately protected so that they cannot be damaged or, where applicable, operated inadvertently by loading, unloading or by movement of the contents of the compartment.

4.9.3. Loading limits, if necessary, should be durably marked in those compartments.

4.9.4. Having regard to the purpose of the craft, the closures of the exterior openings of the luggage and cargo compartments as well as special category spaces should be appropriately weathertight.

## **4.10 Noise levels**

4.10.1. The noise level in crew and passengers' accommodations should be kept as low as possible to enable the public address system to be heard, and should not in general exceed 75 dB(A).

4.10.2. The maximum noise level in the operating compartment should not in general exceed 65 dB(A) to facilitate communication within the compartment and external radiocommunications.

# Chapter 5 - Directional Control Systems

## 5.1 General

5.1.1. Craft should be provided with means for directional control of adequate strength and suitable design to enable the craft's heading and direction of travel to be effectively controlled to the maximum extent possible in the prevailing conditions and craft speed without undue physical effort at all speeds and in all conditions for which the craft is to be certificated. The performance should be verified in accordance with annex 8.

5.1.2. Directional control may be achieved by means of air or water rudders, foils, flaps, steerable propellers or jets, yaw control ports or side thrusters, differential propulsive thrust, variable geometry of the craft or its lift system components or by a combination of these devices.

5.1.3. For the purpose of this chapter, a directional control system includes any steering device or devices, any mechanical linkages and all power or manual devices, controls and actuating systems.

5.1.4. Attention is drawn to the possibility of interaction between directional control systems and stabilization systems. Where such interaction occurs or where dual purpose components are fitted, the requirements of 12.5 and chapters 16 and 17 should also be complied with as applicable.

## 5.2 Reliability

5.2.1. The probability of total failure of all directional control systems should be extremely remote when the craft is operating normally, i.e., excluding emergency situations such as grounding, collision or a major fire.

5.2.2. A design incorporating a power drive or an actuation system employing powered components for normal directional control should provide a secondary means of actuating the device unless an alternative system is provided.

5.2.3. The secondary means of actuating the directional control device may be manually driven when the Administration is satisfied that this is adequate, bearing in mind the craft's size and design and any limitations of speed or other parameters that may be necessary.

5.2.4. The directional control systems should be constructed so that a single failure in one drive or system, as appropriate, will not render any other one inoperable or unable to bring the craft to a safe situation. The Administration may allow a short period of time to permit the connection of a secondary control device when the design of the craft is such that such delay will not, in their opinion, hazard the craft.

5.2.5. A failure mode and effect analysis should include the directional control system.

5.2.6. If necessary to bring the craft to a safe condition, power drives for directional control devices, including those required to direct thrust forward or astern, should become operative automatically, and respond correctly, within 5 s of power or other failure. Back-up electrical systems may be required for the starting-up time of an auxiliary diesel according to 12.2 or an emergency diesel generator according to 12.3.6.

5.2.7. Directional control devices involving variable geometry of the craft or its lift system components should, so far as is practicable, be so constructed that any failure of the drive linkage or actuating system will not significantly hazard the craft.

## 5.3 Demonstrations

5.3.1. The limits of safe use of any of the control system devices should be based on demonstrations and verification process in accordance with annex 8.

5.3.2. Demonstration in accordance with annex 8 should determine any adverse effects upon safe operation of the craft in the event of an uncontrollable total deflection of any one control device. Any limitation on the operation of the craft as may be necessary to ensure that the redundancy or safeguards in the systems provide equivalent safety should be included in the craft operating manual.

## 5.4 Control position

5.4.1. All directional control systems should normally be operated from the craft's operating station.

5.4.2. If directional control systems can also be operated from other positions, then two-way communication should be arranged between the operating station and these other positions.

5.4.3. Adequate indications should be provided at the operating station and these other positions to provide the person controlling the craft with verification of the correct response of the directional control device to this demand, and also to indicate any abnormal responses or malfunction. The indications of steering response or rudder angle indicator should be independent of the system for directional control. The logic of such feedback and indications should be consistent with the other alarms and indications so that in an emergency operators are unlikely to be confused.

## Chapter 6 - Anchoring, Towing and Berthing

### 6.1 General

6.1.1. A primary assumption made in this chapter is that high speed craft will only need an anchor for emergency purposes.

6.1.2. The arrangements for anchoring, towing and berthing and the local craft structure, the design of the anchor, towing and berthing arrangements and the local craft structure should be such that risks to persons carrying out anchoring, towing or berthing procedures are kept to a minimum.

6.1.3. All anchoring equipment, towing bits, mooring bollards, fairleads, cleats and eyebolts should be so constructed and attached to the hull that in use up to design loads, the watertight integrity of the craft will not be impaired. Design loads and any directional limitations assumed should be listed in the craft operating manual.

### 6.2 Anchoring

6.2.1. High speed craft should be provided with at least one anchor with its associated cable or cable and warp and means of recovery. Every craft should be provided with adequate and safe means for releasing the anchor, its cable and warp.

6.2.2. Good engineering practice should be followed in the design of any enclosed space containing the anchor recovery equipment to ensure that persons using the equipment are not put at risk. Particular care should be taken with the means of access to such spaces, the walkways, the illumination and protection from the cable and the recovery machinery.

6.2.3. Adequate arrangements should be provided for two-way voice communication between the operating compartment and persons engaged in dropping, weighing or releasing the anchor.

6.2.4. The anchoring arrangements should be such that any surfaces against which the cable may chafe (for example, hawse pipes and hull obstructions) are designed to prevent the cable from being damaged and fouled. Adequate arrangements should be provided to secure the anchor under all operational conditions.

6.2.5. The craft should be protected so as to minimize the possibility of the anchor and cable damaging the structure during normal operation.

### 6.3 Towing

6.3.1. Adequate arrangements should be provided to enable the craft to be towed in the worst intended conditions. Where towage is to be from more than one point a suitable bridle should be provided.

6.3.2. The towing arrangements should be such that any surfaces against which the towing cable may chafe (for example, fairleads), is of sufficient radius to prevent the cable being damaged when under load.

6.3.3. The maximum permissible speed at which the craft may be towed should be included in the operating manual.

## 6.4 Berthing

6.4.1. Where necessary, suitable fairleads, bitts and mooring ropes should be provided.

6.4.2. Adequate storage space for mooring lines should be provided such that they are readily available and secured against the high relative wind speeds and accelerations which may be experienced.

## Chapter 7 - Fire Safety

### Part A – General

#### 7.1 General requirements

7.1.1. The following basic principles underlay the provisions in this chapter and are embodied therein as appropriate, having regard to the category of craft and the potential fire hazard involved:

- .1. maintenance of the main functions and safety systems of the craft, including propulsion and control, fire detection, alarms and extinguishing capability of unaffected spaces, after fire in any one compartment on board;
- .2. division of the passenger accommodation area for category B craft, in such a way that the occupants of any compartment can escape to an alternative safe area or compartment in case of fire;
- .3. subdivision of the craft by fire-resisting boundaries;
- .4. restricted use of combustible materials and materials generating smoke and toxic gases in a fire;
- .5. detection, containment and extinction of any fire in the space of origin;
- .6. protection of means of escape and access for fire fighting; and
- .7. immediate availability of fire-extinguishing appliances.

7.1.2. The requirements in this chapter are based on the following conditions:

- .1. Where a fire is detected, the crew immediately puts into action the fire-fighting procedures, informs the base port of the accident and prepares for the escape of passengers to alternative safe area or compartment, or, if necessary, for the evacuation of passengers.
- .2. The use of fuel with a flashpoint below 43°C is not recommended. However, fuel with a lower flashpoint, but not lower than 35°C, may be used in gas turbines only subject to compliance with the provisions specified in 7.5.1 to 7.5.6.
- .3. The repair and maintenance of the craft is carried out in accordance with the requirements given in chapters 18 and 19 of this Code.
- .4. Enclosed spaces such as cinemas, discotheques, and similar spaces are not permitted. Refreshment kiosks which do not contain cooking facilities with exposed heating surfaces may be permitted. Galleys, if fitted, should be in full compliance with chapter II-2 of the Convention.
- .5. Dangerous goods may be carried provided the relevant provisions of regulations II-2/53 and 54 of the Convention are complied with.
- .6. Passenger access to vehicle spaces is prohibited during the voyage except when accompanied by a crew member responsible for fire safety. Only authorized crew members should be permitted to enter cargo spaces at sea.

## 7.2 Definitions

7.2.1. "Fire-resisting divisions" are those divisions formed by bulkheads and decks which comply with the following:

- .1. They should be constructed of non-combustible or fire-restricting materials which by insulation or inherent fire-resisting properties satisfy the requirements of 7.2.1.2 to 7.2.1.6.
- .2. They should be suitably stiffened.
- .3. They should be so constructed as to be capable of preventing the passage of smoke and flame up to the end of the appropriate fire protection time.
- .4. Where required, they should maintain load-carrying capabilities up to the end of the appropriate fire protection time.
- .5. They should have thermal properties such that the average temperature on the unexposed side will not rise more than 139°C above the original temperature, nor will the temperature, at any one point, including any joint, rise more than 180°C above the original temperature during the appropriate fire protection time.
- .6. A test in accordance with the test procedures for a prototype bulkhead and deck should be required to ensure that it meets the above requirements.

7.2.2. "Fire-restricting materials" are those materials which have properties complying with the standards developed by the Organization with respect to the following:

- .1. they should have low flame-spread characteristics;
- .2. limit heat flux, due regard being paid to the risk of ignition of furniture in the compartment;
- .3. limited rate of heat release, due regard being paid to the risk of spread of fire to an adjacent compartment; and
- .4. gas and smoke should not be emitted in quantities that could be dangerous to the occupants of the craft.

7.2.3. "Local fire", the standards for compliance with 7.2.2.2 are to be developed by the Organization as applicable to surface materials on bulkheads, wall, and ceiling linings including their supporting structure as considered necessary.

7.2.4. "Non-combustible material" is a material which neither burns nor gives off flammable vapours in sufficient quantity for self-ignition when heated to approximately 750°C, this being determined to the satisfaction of the Administration by an established test procedure. Any other material is a combustible material.

7.2.5. "A standard fire test" is one in which specimens of the relevant bulkheads, decks or other constructions are exposed in a test furnace by specified test method according to the standards developed by the Organization.

7.2.6. Where the words "steel or other equivalent material" occur, "equivalent material" means any non-combustible material which, by itself or due to insulation provided, has structural and integrity properties equivalent to steel at the end of the applicable exposure to the standard fire test (e.g., aluminium alloy with appropriate insulation).

7.2.7. "Low flame-spread" means that the surface thus described will adequately restrict the spread of flame, this being determined by an established test procedure developed by the Organization.

7.2.8. "Smoke-tight" or "capable of preventing the passage of smoke" means that a division made of non-combustible or fire-restricting materials is capable of preventing the passage of smoke.

## 7.3 Classification of space use

7.3.1. For the purposes of classification of space use in accordance with fire hazard risks, the following grouping should apply:

.1. "Areas of major fire hazard" referred to in tables 7.4-1 and 7.4-2 by A, include the following spaces:

- Machinery spaces
- Open vehicle spaces
- Spaces containing dangerous goods
- Special category spaces
- Store-rooms containing flammable liquids

.2. "Areas of moderate fire hazard" referred to in tables 7.4-1 and 7.4-2 by B, include the following spaces:

- Auxiliary machinery spaces, as defined in 1.4.3
- Bond stores containing packaged beverages with alcohol content not exceeding 24% by volume
- Crew accommodations
- Service spaces

.3. "Areas of minor fire hazard" referred to in tables 7.4-1 and 7.4-2 by C, include the following spaces:

- Auxiliary machinery spaces, as defined in 1.4.4
- Cargo spaces
- Fuel tank compartments
- Public spaces
- Tanks, voids and areas of little or no fire risk

.4. "Control stations" referred to in tables 7.4-1 and 7.4-2 by D, as defined in 1.4.13.

.5. "Evacuation stations and external escape routes" referred to in tables 7.4-1 and 7.4-2 by E, include the following areas:

- External stairs and open decks used for escape routes
- Muster stations, internal and external
- Open deck spaces and enclosed promenades forming lifeboat and liferaft embarkation and lowering stations
- The craft's side to the waterline in the lightest seagoing condition, superstructure and deckhouse sides situated below and adjacent to the liferaft's and evacuation slide's embarkation areas

.6. "Open spaces" referred to in tables 7.4-1 and 7.4-2 by F, include the following areas:

- Open spaces locations other than evacuation stations and external escape routes and control stations.



## 7.4 Structural fire protection

	A	B	C	D	E	F
Areas of major fire hazard A	60 1,2	30 1	60 1,8	60 1	60 1	60 1,7
Areas of moderate fire hazard B		30 2	30 8	60 3,4	30 3	3
Areas of minor fire hazard C			30 8	30 3,4	3	3
Control stations D				3,4	3,4	3
Evacuation stations and escape routes E					3	3
Open spaces F						-

**Table 7.4-1 Structural Fire Protection Times for Separating Bulkheads and Decks of Passenger Craft**

	A	B	C	D	E	F
Areas of major fire hazard A	60 1,2	30 1	60 1,8	60 1	60 1	60 1,7
Areas of moderate fire hazard B		2,6	30 6	60 3,4	6	3
Areas of minor fire hazard C			30 8	30 3,4	3	3
Control stations D				3,4	3,4	3
Evacuation stations and escape routes E					3	3
Open spaces F						-

**Table 7.4-2 Protection Times for Separating Bulkheads and Decks of Cargo Craft**

## 7.4.1 Main structure

7.4.1.1. The requirements below apply to all craft irrespective of construction material. The structural fire protection times for separating bulkheads and decks should be in accordance with tables 7.4-1 and 7.4-2, and the structural fire protection times are all based on providing protection for a period of 60 min as referred to in 4.8.1. If any other lesser structural fire protection time is determined for category A craft and cargo craft by 4.8.1, then the times given below in 7.4.2.2 and 7.4.2.3 may be amended pro-rata. In no case should the structural fire protection time be less than 30 min.

7.4.1.2. In using tables 7.4-1 and 7.4-2, it should be noted that the title of each category is intended to be typical rather than restricted. For determining the appropriate fire integrity standards to be applied to boundaries between adjacent spaces, where there is doubt as to their classification for the purpose of this section, they should be treated as spaces within the relevant category having the most stringent boundary requirement.

7.4.1.3. The hull, superstructure, structural bulkheads, decks, deckhouses and pillars should be constructed of approved non-combustible materials having adequate structural properties. The use of other fire-restricting materials may be permitted provided the requirements of this chapter are complied with (including a test procedure, developed by the Organization, for structural strength of composites at elevated temperatures).

## 7.4.2 Fire-resisting divisions

7.4.2.1. Areas of major and moderate fire hazard should be enclosed by fire-resisting divisions complying with the requirements of 7.2.1 except where the omission of any such division would not affect the safety of the craft. These requirements need not apply to those parts of the structure in contact with water at the lightweight condition, but due regard should be given to the effect of temperature of hull in contact with water and heat transfer from any uninsulated structure in contact with water to insulated structure above the water.

7.4.2.2. Fire-resisting bulkheads and decks should be constructed to resist exposure to the standard fire test for a period of 30 min for areas of moderate fire hazard and 60 min for areas of major fire hazards except as provided in 7.4.1.1.

7.4.2.3. Main load-carrying structures within major and moderate fire hazard areas should be arranged to distribute load such that there will be no collapse of the construction of the hull and superstructure when it is exposed to fire for the appropriate fire protection time. The load-carrying structure should also comply with the requirements of 7.4.2.4 and 7.4.2.5.

7.4.2.4. If the structures specified in 7.4.2.3 are made of aluminium alloy their installation should be such that the temperature of the core does not rise more than 200°C above the ambient temperature in accordance with the times in 7.4.1.1 and 7.4.2.2.

7.4.2.5. If the structures specified in 7.4.2.3 are made of combustible material, their insulation should be such that their temperatures will not rise to a level where deterioration of the construction will occur during the exposure to the composite standard fire test developed by the Organization to such an extent that the load-carrying capability, in accordance with the times in 7.4.1.1 and 7.4.2.3, will be impaired.

7.4.2.6. The construction of all doors, and door frames in fire-resisting divisions, with the means of securing them when closed, should provide resistance to fire as well as to the passage of smoke and flame equivalent to that of the bulkheads in which they are situated. Watertight doors of steel need not be insulated. Also, where a fire-resisting division is penetrated by pipes, ducts, controls, electrical cables or for other purposes, arrangements and necessary testing should be made to ensure that the fire-resisting integrity of the division is not impaired.

## 7.4.3 Restricted use of combustible materials

7.4.3.1. All separating divisions, ceilings or linings if not a fire-resisting division, should be of non-combustible or fire-restricting materials.

7.4.3.2. Where insulation is installed in areas in which it could come into contact with any flammable fluids or their vapours, its surface should be impermeable to such flammable fluids or vapours. The exposed surfaces of vapour barriers and adhesives used in conjunction with insulation materials should have low flame-spread characteristics.

7.4.3.3. Furniture and furnishings in public spaces and crew accommodation should comply with the following standards:

.1. all case furniture is constructed entirely of approved non-combustible or fire-restricting materials, except that a combustible veneer with a calorific value not exceeding 45 MJ/m<sup>2</sup> may be used on the exposed surface of such articles;

.2. all other furniture such as chairs, sofas and tables is constructed with frames of non-combustible or fire-restricting materials;

.3. all draperies, curtains and other suspended textile materials have qualities of resistance to the propagation of flame in accordance with standards developed by the Organization:

.4. all upholstered furniture has qualities of resistance to the ignition and propagation of flame in accordance with standards developed by the Organization;

.5. all bedding components comply with the standards developed by the Organization; and

.6. all deck finish materials comply with the standards developed by the Organization.

7.4.3.4. The following surfaces should, as a minimum standard be constructed of materials having low flame-spread characteristics:

.1. exposed surfaces in corridors and stairway enclosures, and of bulkheads, wall and ceiling linings in all accommodation and service spaces and control stations;

.2. concealed or inaccessible spaces in accommodation, service spaces and control stations.

7.4.3.5. Any thermal and acoustic insulation material, if not in compliance with 7.2.1 or 7.2.2, should be of non-combustible material.

7.4.3.6. Materials used in the craft, when exposed to fire, should not emit smoke or toxic gases in quantities that could be dangerous to humans as determined in tests of a standard developed by the Organization.

7.4.3.7. Void compartments, where low density combustible materials are used to provide buoyancy, should be protected from adjacent fire hazard areas by fire-resisting divisions, in accordance with tables 7.4-1 and 7.4-2. Also, the space and closures to it should be gastight but it should be ventilated to atmosphere.

7.4.3.8. In compartments where smoking is allowed, suitable non-combustible ash containers should be provided. In compartments where smoking is not allowed, adequate notices should be displayed.

7.4.3.9. The exhaust gas pipes should be arranged so that the risk of fire is kept to a minimum. To this effect, the exhaust system should be insulated and all the compartments and structures which are contiguous with the exhaust system, or those which may be affected by increased temperatures caused by waste gases in normal operation or in an emergency, should be constructed of non-combustible material or be shielded and insulated with non-combustible material to protect from high temperatures.

7.4.3.10. The design and arrangement of the exhaust manifolds or pipes should be such as to ensure the safe discharge of exhaust gases.

## **7.4.4 Arrangement**

7.4.4.1. Internal stairways which serve more than two decks of accommodation should be enclosed at all levels with smoke-tight divisions of non-combustible or fire-restricting materials, and where only two decks are served, such enclosures should be provided on at least one level. Stairways may be fitted in the open in a public space, provided they lie wholly within such public space.

7.4.4.2. Lift trunks should be so fitted as to prevent the passage of smoke and flame from one deck to another and should be provided with means of closing so as to permit the control of draught and smoke.

7.4.4.3. In accommodation and service spaces, control stations, corridors and stairways air spaces enclosed behind ceilings, panelling or linings should be suitably divided by close fitting draught stops not more than 14 m apart.

## 7.5 Fuel and other flammable fluid tanks and systems

7.5.1. Tanks containing fuel and other flammable fluids should be separated from passenger, crew, and baggage compartments by vapour-proof enclosures or cofferdams which are suitably ventilated and drained.

7.5.2. Fuel oil tanks should not be located in or contiguous to major fire hazard areas. However, flammable fluids of a flashpoint not less than 60°C may be located within such areas provided the tanks are made of steel or other equivalent material.

7.5.3. Every oil fuel pipe which, if damaged, would allow oil to escape from a storage, settling or daily service tank should be fitted with a cock or valve directly on the tank capable of being closed from a position outside the space concerned in the event of a fire occurring in the space in which such tanks are situated.

7.5.4. Pipes, valves and couplings conveying flammable fluids should be of steel or such alternative material satisfactory to a standard, in respect of strength and fire integrity having regard to the service pressure and the spaces in which they are installed. Wherever practicable, the use of flexible pipes should be avoided.

7.5.5. Pipes, valves and couplings conveying flammable fluids should be arranged as far from hot surfaces or air intakes of engine installations, electrical appliances and other potential sources of ignition as is practicable and be located or shielded so that the likelihood of fluid leakage coming into contact with such sources of ignition is kept to a minimum.

7.5.6. Fuel with a flashpoint below 35°C should not be used. In every craft in which fuel with a flashpoint below 43°C is used, the arrangements for the storage, distribution and utilization of the fuel should be such that, having regard to the hazard of fire and explosion which the use of such fuel may entail, the safety of the craft and of persons on board is preserved. The arrangements should comply, in addition to the requirements of 7.5.1 to 7.5.5, with the following provisions:

.1. tanks for the storage of such fuel should be located outside any machinery space and at a distance of not less than 760 mm inboard from the shell side and bottom plating, and from decks and bulkheads;

.2. arrangements should be made to prevent overpressure in any fuel tank or in any part of the oil fuel system, including the filling pipes. Any relief valves and air or overflow pipes should discharge to a position which, in the opinion of the Administration, is safe;

.3. the spaces in which fuel tanks are located should be mechanically ventilated using exhaust fans providing not less than six air changes per hour. The fans should be such as to avoid the possibility of ignition of flammable gas air mixtures. Suitable wire mesh guards should be fitted over inlet and outlet ventilation openings. The outlets for such exhausts should be discharged to a position which, in the opinion of the Administration, is safe. 'No Smoking' signs should be posted at the entrances to such spaces;

.4. earthed electrical distribution systems should not be used, with the exception of earthed intrinsically safe circuits;

.5. suitable certified safe type electrical equipment should be used in all spaces where fuel leakage could occur including ventilation system. Only electrical equipment and fittings essential for operational purposes should be fitted in such spaces;

.6. a fixed vapour detection system should be installed in each space through which fuel lines pass, with alarms provided at the continuously manned control station;

.7. every fuel tank should, where necessary, be provided with "savealls" or gutters which would catch any fuel which may leak from such tank;

.8. safe and efficient means of ascertaining the amount of fuel contained in any tank should be provided. Sounding pipes should not terminate in any space where the risk of ignition of spillage from the sounding pipe might arise. In particular, they should not terminate in passenger or crew spaces. The use of gauge glasses is prohibited. Other means of ascertaining the amount of fuel contained in any tank may be permitted if such means do not require penetration below the top of the tank, and providing their failure or overflowing of the tank will not permit the release of fuel;

.9. during bunkering operations no passenger should be on board the craft or in the vicinity of the bunkering station, and adequate 'No Smoking' and 'No Naked Lights' signs should be posted. Vessel-to-shore fuel connections should be of closed type and suitably grounded during bunkering operations;

.10. the provision of fire detection and extinguishing systems in spaces where non-integral fuel tanks are located should be in accordance with paragraphs 7.7.1 to 7.7.4; and

.11. refuelling of the craft should be done at the approved refuelling facilities, detailed in the route operational manual, at which the following fire appliances are provided:

.11.1. a suitable foam applicator system consisting of monitors and foam making branch pipes capable of delivering foam solution at a rate of not less than 500 l/min for not less than 10 min;

.11.2. dry powder extinguishers of total capacity not less than 50 kg; and

.11.3. carbon dioxide extinguishers of total capacity not less than 16 kg.

## **7.6 Ventilation**

7.6.1. The main inlets and outlets of all ventilation systems should be capable of being closed from outside the spaces being ventilated. In addition, such openings to areas of major fire hazard should be capable of being closed from a continuously manned control station.

7.6.2. All ventilation fans should be capable of being stopped from outside the spaces which they serve, and from outside the spaces in which they are installed. Ventilation fans serving major fire hazard areas should be capable of being operated from a continuously manned control station. The means provided for stopping the power ventilation to the machinery space should be separated from the means provided for stopping ventilation of other spaces.

7.6.3. Major fire hazard areas and main passenger spaces serving as muster stations should have separate ventilation systems and ventilation ducts. Ventilation ducts for major fire hazard areas should not pass through other spaces, and ducts for ventilation of other spaces should not pass through major fire hazard areas.

7.6.4. Where, of necessity, a ventilation duct passes through a fire-resisting or smoke-tight division, a fail safe automatic closing fire damper should be fitted adjacent to the division. The duct between the division and the damper should be of steel or other equivalent material and insulated to the same standard as required for the fire-resisting division.

7.6.5. Where ventilation systems penetrate decks, the arrangements should be such that the effectiveness of the deck in resisting fire is not thereby impaired and precautions should be taken to reduce the likelihood of smoke and hot gases passing from one between deck space to another through the system.

7.6.6. All dampers fitted on fire-resisting or smoke-tight divisions should also be capable of being manually closed from each accessible side of the division in which they are fitted, and remotely closed from the continuously manned control station.

## **7.7 Fire detection and extinguishing systems**

7.7.1. Areas of major and moderate fire hazard and other enclosed spaces in the accommodation not regularly occupied, such as toilets, stairway enclosures and corridors should be provided with an approved automatic smoke detection system and manually operated call points to indicate at the control station the location of outbreak of a fire in all normal operating conditions of the installations. Main propulsion machinery room(s) should in addition have detectors sensing other than smoke and be supervised by TV cameras monitored from the operating compartment. Manually operated call points should be installed throughout the accommodation spaces, service spaces and, where necessary, control stations. One manually operated call point should be located at each exit from these spaces and from areas of major fire hazard.

7.7.2. The fixed fire detection and fire alarm systems should comply with the following requirements.

7.7.2.1. General requirements

- .1. Any required fixed fire detection and fire alarm system with manually operated call points should be capable of immediate operation at all times.
- .2. Power supplies and electric circuits necessary for the operation of the system should be monitored for loss of power or fault conditions as appropriate. Occurrence of a fault condition should initiate a visual and audible fault signal at the control panel which should be distinct from a fire signal.
- .3. There should be not less than two sources of power supply for the electrical equipment used in the operation of the fixed fire detection and fire alarm systems, one of which should be an emergency source. The supply should be provided by separate feeders reserved solely for that purpose. Such feeders should run to an automatic change-over switch situated in or adjacent to the control panel for the fire detection system.
- .4. Detectors and manually operated call points should be grouped into sections. The activation of any detector or manually operated call point should initiate a visual and audible fire signal at the control panel and indicating units. If the signals have not received attention within two minutes an audible alarm should be automatically sounded throughout the crew accommodation and service spaces, control stations and machinery spaces. This alarm sounder system need not be an integral part of the fire detection system.
- .5. The control panel should be located in the operating compartment or in the main fire control station.
- .6. Indicating units should, as a minimum, denote the section in which a detector or manually operated call point has operated. At least one unit should be so located that it is easily accessible to responsible members of the crew at all times, when at sea or in port, except when the craft is out of service. One indicating unit should be located in the operating compartment if the control panel is located in the space other than the operating compartment.
- .7. Clear information should be displayed on or adjacent to each indicating unit about the spaces covered and the location of the sections.
- .8. Where the fire detection system does not include means of remotely identifying each detector individually, no section covering more than one deck within accommodation spaces, service spaces and control stations should normally be permitted except a section which covers an enclosed stairway. In order to avoid delay in identifying the source of fire, the number of enclosed spaces included in each section should be limited as determined by the Administration. In no case should more than 50 enclosed spaces be permitted in any section. If the detection system is fitted with remotely and individually identifiable fire detectors, the sections may cover several decks and serve any number of enclosed spaces.
- .9. In passenger craft, if there is no fire detection system capable of remotely and individually identifying each detector, a section of detectors should not serve spaces on both sides of the craft nor on more than one deck and neither should it be situated in more than one zone according to 7.11.1 except that the Administration, if it is satisfied that the protection of the craft against fire will not thereby be reduced, may permit such a section of detectors to serve both sides of the craft and more than one deck. In passenger craft fitted with individually identifiable fire detectors, a section may serve spaces on both sides of the craft and on several decks.
- .10. A section of fire detectors which covers a control station, a service space or an accommodation space, should not include a machinery space of major fire hazard.
- .11. Detectors should be operated by heat, smoke or other products of combustion, flame, or any combination of these factors. Detectors operated by other factors indicative of incipient fires may be considered by the Administration provided that they are no less sensitive than such detectors. Flame detectors should only be used in addition to smoke or heat detectors.
- .12. Suitable instructions and component spares for testing and maintenance should be provided.
- .13. The function of the detection system should be periodically tested by means of equipment producing hot air at the appropriate temperature, or smoke or aerosol particles having the appropriate range of density or particle size, or other phenomena associated with incipient fires to which the detector is designed to respond. All detectors should be of a type such that they can be tested for correct operation and restored to normal surveillance without the renewal of any component.
- .14. The fire detection system should not be used for any other purpose, except that closing of fire doors and similar functions may be permitted at the control panel.

.15. Fire detection systems with a zone address identification capability should be so arranged that:

.1. a loop cannot be damaged at more than one point by a fire;

.2. means are provided to ensure that any fault (e.g., power break; short circuit; earth) occurring in the loop should not render the whole loop ineffective;

.3. all arrangements are made to enable the initial configuration of the system to be restored in the event of failure (electrical, electronic, informatic); and

.4. the first initiated fire alarm should not prevent any other detector to initiate further fire alarms.

#### 7.7.2.2. Installation requirements:

.1. Manually operated call points should be installed throughout the accommodation spaces, service spaces and control stations. One manually operated call point should be located at each exit. Manually operated call points should be readily accessible in the corridors of each deck such that no part of the corridor is more than 20 m from a manually operated call point.

.2. Smoke detectors should be installed in all stairways, corridors and escape routes within accommodation spaces. Consideration should be given to the installation of special purpose smoke detectors within ventilation ducting.

.3. Where a fixed fire detection and fire alarm system is required for the protection of spaces other than those specified in .2, at least one detector complying with 7.7.2.1.11 should be installed in each such space.

.4. Detectors should be located for optimum performance. Positions near beams and ventilation ducts or other positions where patterns of air flow could adversely affect performance and positions where impact or physical damage is likely should be avoided. In general, detectors which are located on the overhead should be a minimum distance of 0.5 m away from bulkheads.

.5. The maximum spacing of detectors should be in accordance with the table below:

Type of detector	Maximum floor area per detector	Maximum distance apart between centres	Maximum distance away from bulkheads
Heat	37 m <sup>2</sup>	9 m	4.5 m
Smoke	74 m <sup>2</sup>	11 m	5.5 m

The Administration may require or permit other spacings based upon test data which demonstrate the characteristics of the detectors.

.6. Electrical wiring which forms part of the system should be so arranged as to avoid machinery spaces of major fire hazard, and other enclosed spaces of major fire hazard except, where it is necessary, to provide for fire detection or fire alarm in such spaces or to connect to the appropriate power supply.

#### 7.7.2.3. Design requirements:

.1. The system and equipment should be suitably designed to withstand supply voltage variation and transients, ambient temperature changes, vibration, humidity, shock, impact and corrosion normally encountered in ships.

.2. Smoke detectors required by paragraph 7.7.2.2.2 should be certified to operate before the smoke density exceeds 12.5% obscuration per metre, but not until the smoke density exceeds 2% obscuration per metre. Smoke detectors to be installed in other spaces should operate within sensitivity limits to the satisfaction of the Administration having regard to the avoidance of detector insensitivity or over-sensitivity.

.3. Heat detectors should be certified to operate before the temperature exceeds 78°C but not until the temperature exceeds 54°C, when the temperature is raised to those limits at a rate less than 1°C per minute. At higher rates of temperature rise, the heat detector should operate within temperature limits having regard to the avoidance of detector insensitivity or over-sensitivity.

.4. At the discretion of the Administration, the permissible temperature of operation of heat detectors may be increased to 30°C above the maximum deckhead temperature in drying rooms and similar spaces of a normal high ambient temperature.

.5. Flame detectors referred to in 7.7.2.1.11 should have a sensitivity sufficient to determine flame against an illuminated space background and a false signal identification system.

7.7.3. A fixed fire detection and fire alarm system for periodically unattended machinery spaces should comply with the following requirements:

.1. The fire detection system should be so designed and the detectors so positioned as to detect rapidly the onset of fire in any part of those spaces and under any normal conditions of operation of the machinery and variations of ventilation as required by the possible range of ambient temperatures. Except in spaces of restricted height and where their use is specially appropriate, detection system using only thermal detectors should not be permitted. The detection system should initiate audible and visual alarms distinct in both respects from the alarms of any other system not indicating fire, in sufficient places to ensure that the alarms are heard and observed on the navigating bridge and by a responsible engineer officer. When the operating compartment is unmanned the alarm should sound in a place where a responsible member of the crew is on duty.

.2. After installation, the system should be tested under varying conditions of engine operation and ventilation.

7.7.4. Areas of major fire hazard should be protected by an approved fixed extinguishing system operable from the control position which is adequate for the fire hazard that may exist. The system should be capable of local manual control and remote control from the continuously manned control stations.

7.7.5. In all craft where gas is used as the extinguishing medium, the quantity of gas should be sufficient to provide two independent discharges. The second discharge into the space should only be activated (released) manually from a position outside the space being protected. Where the space has a second fixed means of extinguishing installed, then the second discharge should not be required.

7.7.6.1. The fixed fire-extinguishing systems should comply with the following requirements:

.1. The use of a fire-extinguishing medium which, in the opinion of the Administration, either by itself or under expected conditions of use will adversely affect the earth's ozone layer and/or gives off toxic gases in such quantities as to endanger persons should not be permitted.

.2. The necessary pipes for conveying fire-extinguishing medium into protected spaces should be provided with control valves so marked as to indicate clearly the spaces to which the pipes are led. Non-return valves should be installed in discharge lines between cylinders and manifolds. Suitable provision should be made to prevent inadvertent admission of the medium to any space.

.3. The piping for the distribution of fire-extinguishing medium should be arranged and discharge nozzles so positioned that a uniform distribution of medium is obtained.

.4. Means should be provided to close all openings which may admit air to, or allow gas to escape from, a protected space.

.5. Where the volume of free air contained in air receivers in any space is such that, if released in such space in the event of fire, such release of air within that space would seriously affect the efficiency of the fixed fire-extinguishing system, the Administration should require the provision of an additional quantity of fire-extinguishing medium.

.6. Means should be provided for automatically giving audible warning of the release of fire-extinguishing medium into any space in which personnel normally work or to which they have access. The alarm should operate for a suitable period before the medium is released.

.7. The means of control of any fixed gas fire-extinguishing system should be readily accessible and simple to operate and should be grouped together in as few locations as possible at positions not likely to be cut off by a fire in a protected space. At each location there should be clear instructions relating to the operation of the system having regard to the safety of personnel.

.8. Automatic release of fire-extinguishing medium should not be permitted.



.9. Where the quantity of extinguishing medium is required to protect more than one space, the quantity of medium available need not be more than the largest quantity required for any one space so protected.

.10. Pressure containers required for the storage of fire-extinguishing medium should be located outside protected spaces in accordance with 7.7.6.1.13.

.11. Means should be provided for the crew to safely check the quantity of medium in the containers.

.12. Containers for the storage of fire-extinguishing medium and associated pressure components should be designed to pressure codes of practice to the satisfaction of the Administration having regard to their locations and maximum ambient temperatures expected in service.

.13. When the fire-extinguishing medium is stored outside a protected space, it should be stored in a room which should be situated in a safe and readily accessible position and should be effectively ventilated. Any entrance to such a storage room should preferably be from the open deck and in any case should be independent of the protected space. Access doors should open outwards, and bulkheads and decks including doors and other means of closing any opening therein, which form the boundaries between such rooms and adjoining enclosed spaces, should be gas tight. Such storage rooms should be treated as control stations.

.14. Spare parts for the system should be stored on board or at a base port.

#### 7.7.6.2. Carbon dioxide systems

.1. For cargo spaces, the quantity of carbon dioxide available should, unless otherwise provided, be sufficient to give a minimum volume of free gas equal to 30% of the gross volume of the largest cargo space so protected in the craft.

.2. For machinery spaces, the quantity of carbon dioxide carried should be sufficient to give a minimum volume of free gas equal to the larger of the following volumes, either:

.2.1. 40% of the gross volume of the largest machinery space so protected, the volume to exclude that part of the casing above the level at which the horizontal area of the casing is 40% or less of the horizontal area of the space concerned taken midway between the tank top and the lowest part of the casing; or

.2.2. 35% of the gross volume of the largest machinery space protected, including the casing;

provided that the above-mentioned percentages may be reduced to 35% and 30% respectively for cargo craft of less than 2,000 tons gross tonnage; provided also that if two or more machinery spaces are not entirely separate they should be considered as forming one space.

.3. For the purpose of this paragraph the volume of free carbon dioxide should be calculated at 0.56 m<sup>3</sup>/kg.

.4. For machinery spaces, the fixed piping system should be such that 85% of the gas can be discharged into the space within 2 min.

.5. Two separate controls should be provided for releasing carbon dioxide into a protected space and to ensure the activation of the alarm. One control should be used to discharge the gas from its storage containers. A second control should be used for opening the valve of the piping which conveys the gas into the protected spaces.

.6. The two controls should be located inside a release box clearly identified for the particular space. If the box containing the controls is to be locked, a key to the box should be in a break-glass type enclosure conspicuously located adjacent to the box.

7.7.7. Control stations, accommodation spaces and service spaces should be provided with portable fire extinguishers of appropriate types. At least five portable extinguishers should be provided, and so positioned as to be readily available for immediate use. In addition, at least one extinguisher suitable for machinery space fires should be positioned outside each machinery space entrance.

7.7.8. Fire pumps, and appropriate associated equipment, or alternative effective fire-extinguishing systems should be fitted as follows:

.1. At least two independently driven pumps should be arranged. Each pump should have at least two thirds the capacity of a bilge pump as determined by 10.3.5 and 10.3.6 but not less than 25 m<sup>3</sup>/h. Each fire pump should be able to deliver sufficient quantity and pressure of water to simultaneously operate the hydrants as required by .4.

.2. The arrangement of the pumps should be such that in the event of a fire in any one compartment all the fire pumps will not be put out of action.

.3. Isolating valves to separate the section of the fire main within the machinery space containing the main fire pump or pumps from the rest of the fire main should be fitted in an easily accessible and tenable position outside the machinery spaces. The fire main should be so arranged that when the isolating valves are shut all the hydrants on the craft, except those in the machinery space referred to above, can be supplied with water by a fire pump not located in this machinery space through pipes which do not enter this space.

.4. Hydrants should be arranged so that any location on the craft can be reached by the water jets from two fire hoses from two different hydrants, one of the jets being from a single length of hose. Special category spaces hydrants should be located so that any location within the space can be reached by two water jets from two different hydrants, each jet being supplied from a single length of hose.

.5. Each fire hose should be of non-perishable material and have a maximum length approved by the Administration. Fire hoses, together with any necessary fittings and tools, should be kept ready for use in conspicuous positions near the hydrants. All fire hoses in interior locations should be connected to the hydrants at all times. One fire hose should be provided for each hydrant as required by .4.

.6. Each fire hose should be provided with a nozzle of an approved dual purpose type (i.e. spray/jet type) incorporating a shutoff.

## **7.8 Protection of special category spaces**

### **7.8.1 Structural protection**

.1. Boundaries of special category spaces should be insulated in accordance with tables 7.4-1 and 7.4-2. The standing deck of a special category space need only be insulated on the underside if required.

.2. Indicators should be provided on the navigating bridge which should indicate when any door leading to or from the special category space is closed.

### **7.8.2 Fixed fire-extinguishing system**

Each special category space should be fitted with an approved fixed pressure water-spraying system for manual operation which should protect all parts of any deck and vehicle platform in such space, provided that the Administration may permit the use of any other fixed fire-extinguishing system that has been shown by full-scale test in conditions simulating a flowing petrol fire in a special category space to be not less effective in controlling fires likely to occur in such a space.

### **7.8.3 Patrols and detection**

7.8.3.1. A continuous fire patrol should be maintained in special category spaces unless a fixed fire detection and fire alarm system, complying with the requirements of 7.7.2, and a television surveillance system are provided. The fixed fire detection system should be capable of rapidly detecting the onset of fire. The spacing and location of detectors should be tested taking into account the effects of ventilation and other relevant factors.

7.8.3.2. Manually operated call points should be provided as necessary throughout the special category spaces and one should be placed close to each exit from such spaces.

### **7.8.4 Fire-extinguishing equipment**

7.8.4.1. There should be provided in each special category space:

.1. at least three water fog applicators;

.2. one portable foam applicator unit consisting of an air-foam nozzle of an inductor type capable of being connected to the fire main by a fire hose, together with a portable tank containing 20 l of foam-making liquid and

one spare tank. The nozzle should be capable of producing effective foam suitable for extinguishing an oil fire of at least 1.5 m<sup>3</sup>/min. At least two portable foam applicator units should be available in the craft for use in such space; and

.3. portable fire extinguishers should be located so that no point in the space is more than approximately 15 m walking distance from an extinguisher, provided that at least one portable extinguisher is located at each access to such space.

## **7.8.5 Ventilation system**

7.8.5.1. There should be provided an effective power ventilation system for the special category spaces sufficient to give at least 10 air changes per hour while navigating and 20 air changes per hour at the quayside during vehicle loading and unloading operations. The system for such spaces should be entirely separated from other ventilation systems and should be operating at all times when vehicles are in such spaces. Ventilation ducts serving special category spaces capable of being effectively sealed should be separated for each such space. The system should be capable of being controlled from a position outside such spaces.

7.8.5.2. The ventilation should be such as to prevent air stratification and the formation of air pockets.

7.8.5.3. Means should be provided to indicate in the operating compartment any loss or reduction of the required ventilating capacity.

7.8.5.4. Arrangements should be provided to permit a rapid shutdown and effective closure of the ventilation system in case of fire, taking into account the weather and sea conditions.

7.8.5.5. Ventilation ducts, including dampers should be made of steel or other equivalent material.

## **7.8.6 Scuppers, bilge pumping and drainage**

7.8.6.1. In view of the serious loss of stability which could arise due to large quantities of water accumulating on the deck or decks consequent to the operation of the fixed pressure water-spraying system, scuppers should be fitted so as to ensure that such water is rapidly discharged directly overboard. Alternatively, pumping and drainage facilities should be provided additional to the requirements of chapter 10.

## **7.8.7 Precautions against ignition of flammable vapours**

7.8.7.1. On any deck or platform, if fitted, on which vehicles are carried and on which explosive vapours might be expected to accumulate, except platforms with openings of sufficient size permitting penetration of petrol gases downwards, equipment which may constitute a source of ignition of flammable vapours and, in particular, electrical equipment and wiring, should be installed at least 450 mm above the deck or platform. Electrical equipment installed at more than 450 mm above the deck or platform should be of a type so enclosed and protected as to prevent the escape of sparks. However, if the installation of electrical equipment and wiring at less than 450 mm above the deck or platform is necessary for the safe operation of the craft, such electrical equipment and wiring may be installed provided that it is of a type approved for use in an explosive petrol and air mixture.

7.8.7.2. Electrical equipment and wiring, if installed in an exhaust ventilation duct, should be of a type approved for use in explosive petrol and air mixtures and the outlet from any exhaust duct should be sited in a safe position, having regard to other possible sources of ignition.

## **7.9 Miscellaneous**

7.9.1. There should be permanently exhibited, for the guidance of the master and officers of the craft, fire control plans showing clearly for each deck the following positions: the control stations, the sections of the craft which are enclosed by fire-resisting divisions together with particulars of the fire alarms, fire detection systems, the sprinkler installations, the fixed and portable fire-extinguishing appliances, the means of access to the various compartments and decks in the craft, the ventilating system including particulars of the master fan controls, the positions of dampers and identification numbers of the ventilating fans serving each section of the craft, the location of the international shore connection, if fitted, and the position of all means of control referred to in 7.5.3, 7.6.2, 7.7.1 and 7.7.4. The text of such plans should be in the official language of the flag State.

However, if the language is neither English nor French, a translation into one of those languages should be included.

7.9.2. A duplicate set of fire control plans or a booklet containing such plans should be permanently stored in a prominently marked weathertight enclosure outside the deckhouse for the assistance of shore side fire-fighting personnel.

### 7.9.3. Openings in fire-resisting divisions

7.9.3.1. Except for the hatches between cargo, special category, store, and baggage spaces and between such spaces and the weather decks, all openings should be provided with permanently attached means of closing which should be at least as effective for resisting fires as the divisions in which they are fitted.

7.9.3.2. It should be possible for each door to be opened and closed from each side of the bulkhead by one person only.

7.9.3.3. Fire doors bounding major fire hazard areas and stairway enclosures should satisfy the following requirements:

.1. The doors should be self-closing and be capable of closing with an angle of inclination of up to 3.5° opposing closure, and should have an approximately uniform rate of closure of no more than 40 s and no less than 10 s with the craft in the upright position.

.2. Remote-controlled sliding or power-operated doors should be equipped with an alarm that sounds at least 5 s but no more than 10 s before the door begins to move and continue sounding until the door is completely closed. Doors designed to reopen upon contacting an object in their paths should reopen sufficiently to allow a clear passage of at least 0.75 m, but no more than 1 m.

.3. All doors should be capable of remote and automatic release from a continuously manned central control station, either simultaneously or in groups, and also individually from a position at both sides of the door. Indication should be provided at the fire control panel in the continuously manned control station whether each of the remote-controlled doors is closed. The release mechanism should be so designed that the door will automatically close in the event of disruption of the control system or central power supply. Release switches should have an on-off function to prevent automatic resetting of the system. Hold-back hooks not subject to control station release should be prohibited.

.4. Local power accumulators for power-operated doors should be provided in the immediate vicinity of the doors to enable the doors to be operated at least ten times (fully opened and closed) using the local controls

.5. Double-leaf doors equipped with a latch necessary to their fire integrity should have a latch that is automatically activated by the operation of the doors when released by the system.

.6. Doors giving direct access to special category spaces which are power-operated and automatically closed need not be equipped with alarms and remote-release mechanisms required in .2 and .3.

7.9.3.4. The requirements for integrity of fire-resisting divisions of the outer boundaries facing open spaces of a craft should not apply to the glass partitions, windows and sidescuttles. Similarly, the requirements for integrity of fire-resisting divisions facing open spaces should not apply to exterior doors in superstructures and deckhouses.

## 7.10 Fireman's outfits

7.10.1. All craft other than category A passenger craft should carry at least two fireman's outfits complying with the requirements of 7.10.3.

7.10.1.1. In addition, there should be provided in category B passenger craft for every 80 m, or part thereof, of the aggregate of the length of all passenger spaces and service spaces on the deck which carries such spaces or, if there is more than one such deck, on the deck which has the largest aggregate of such length, two fireman's outfits and two sets of personal equipment, each set comprising the items stipulated in 7.10.3.1.1 to 7.10.3.1.3;

7.10.1.2. In category B passenger craft, for each pair of breathing apparatus there should be provided one water fog applicator which should be stored adjacent to such apparatus.

7.10.1.3. The Administration may require additional sets of personal equipment and breathing apparatus, having due regard to the size and type of the craft.

7.10.2. The fireman's outfits or sets of personal equipment should be so stored as to be easily accessible and ready for use and, where more than one fireman's outfit or more than one set of personal equipment is carried, they should be stored in widely separated positions. In passenger craft, at least two fireman's outfits and one set of personal equipment should be available at any one control station.

7.10.3. A fireman's outfit should consist of:

.1. Personal equipment comprising:

.1. protective clothing of material to protect the skin from the heat radiating from the fire and from burns and scalding by steam or gases. The outer surface should be water-resistant;

.2. boots and gloves of rubber or other electrically non-conductive material;

.3. a rigid helmet providing effective protection against impact:

.4. an electric safety lamp (hand lantern) of an approved type with a minimum burning period of 3 h; and

.5. an axe.

.2. A breathing apparatus of an approved type which may be either:

.1. a smoke helmet or smoke mask which should be provided with a suitable air pump and a length of air hose sufficient to reach from the open deck, well clear of hatch or doorway, to any part of the holds or machinery spaces. If, in order to comply with this subparagraph, an air hose exceeding 36 m in length would be necessary, a self-contained breathing apparatus should be substituted or provided in addition as determined by the Administration, or

.2. a self-contained compressed-air-operated breathing apparatus, the volume of air contained in the cylinders of which should be at least 1,200 l, or other self-contained breathing apparatus which should be capable of functioning for at least 30 min. A number of spare charges, suitable for use with the apparatus provided, should be available on board.

.3. For each breathing apparatus, a fireproof lifeline of sufficient length and strength should be provided capable of being attached by means of a snaphook to the harness of the apparatus or to a separate belt in order to prevent the breathing apparatus becoming detached when the lifeline is operated.

## **Part B - Requirements for Passenger Craft**

### **7.11 Arrangement**

7.11.1. For category B craft, the public spaces should be divided into zones according to the following:

.1. The craft should be divided into at least two zones. The mean length of each zone should not exceed 40 m.

.2. For the occupants of each zone there should be an alternative safe area to which it is possible to escape in case of fire. The alternative safe area should be separated from other passenger zones by smoke-tight divisions of non-combustible materials or fire-restricting materials extending from deck to deck. The alternative safe area can be another passenger zone provided the additional number of passengers may be accommodated in an emergency.

.3. The alternative safe area should, as far as practicable, be located adjacent to the passenger zone it is intended to serve. There should be at least two exits from each passenger zone, located as far away from each other as possible, leading to the alternative safe area. Escape routes should be provided to enable all passengers and crew to be safely evacuated from the alternative safe area.

7.11.2. Category A craft need not be divided into zones.

7.11.3. Control stations, life-saving appliance stowage positions, escape routes and places of embarkation into survival craft should not, as far as practicable, be located adjacent to any major or moderate fire hazard areas.

## 7.12 Ventilation

. The ventilation fans of each zone in the accommodation spaces should also be capable of being independently controlled from a continuously manned control station

## 7.13 Fixed sprinkler System

7.13.1. Public spaces and service spaces, storage rooms other than those containing flammable liquids, and similar spaces should be protected by a fixed sprinkler system meeting a standard developed by the Organization. Manually operated sprinkler systems should be divided into sections of appropriate size, and the valves for each section, start of sprinkler pump(s) and alarms should be operable from two spaces separated as widely as possible, one of which should be a continuously manned control station. In category B craft, no section of the system should serve more than one of the zones required in 7.11.

7.13.2. Plans of the system should be displayed at each operating station. Suitable arrangements should be made for the drainage of water discharged when the system is activated.

## Part C - Requirements for Cargo Craft

### 7.14 Control station

. Control stations, life-saving appliances stowage positions, escape routes and places of embarkation into survival craft should be located adjacent to crew accommodation areas.

### 7.15 Cargo spaces

. Cargo spaces, except open deck areas or refrigerated holds, should be provided with an approved automatic smoke detection system complying with 7.7.2 to indicate at the control station the location of outbreak of a fire in all normal operating conditions of the installations and should be protected by an approved fixed quick acting fire-extinguishing system complying with 7.7.6.1 operable from the control station.

## Chapter 8 - Life-saving Appliances and Arrangements

### 8.1 General and definitions

8.1.1. Life-saving appliances and arrangements should enable abandonment of the craft in accordance with the requirements of 4.7 and 4.8.

8.1.2. Except where otherwise provided in this Code, the life-saving appliances and arrangements required by this chapter should meet the detailed specifications set out in part C of chapter III of the Convention and be approved by the Administration.

8.1.3. Before giving approval to life-saving appliances and arrangements, the Administration should ensure that such life-saving appliances and arrangements:

.1. are tested to confirm that they comply with the requirements of this chapter, in accordance with the recommendations of the Organization; or

.2. have successfully undergone, to the satisfaction of the Administration, tests which are substantially equivalent to those specified in those recommendations.

8.1.4. Before giving approval to novel life-saving appliances or arrangements, the Administration should ensure that such appliances or arrangements:

.1. provide safety standards at least equivalent to the requirements of this chapter and have been evaluated and tested in accordance with the recommendations of the Organization; or

.2. have successfully undergone, to the satisfaction of the Administration, evaluation and tests which are substantially equivalent to those recommendations.

8.1.5. Before accepting life-saving appliances and arrangements that have not been previously approved by the Administration, the Administration should be satisfied that life-saving appliances and arrangements comply with the requirements of this chapter.

8.1.6. Except where otherwise provided in this Code, life-saving appliances required by this chapter for which detailed specifications are not included in part C of chapter III of the Convention should be to the satisfaction of the Administration.

8.1.7. The Administration should require life-saving appliances to be subjected to such production tests as are necessary to ensure that the life-saving appliances are manufactured to the same standard as the approved prototype.

8.1.8. Procedures adopted by the Administration for approval should also include the conditions whereby approval would continue or would be withdrawn

8.1.9. The Administration should determine the period of acceptability of life-saving appliances which are subject to deterioration with age. Such life-saving appliances should be marked with a means for determining their age or the date by which they should be replaced.

8.1.10. For the purposes of this chapter, unless expressly provided otherwise:

.1. "Detection" is the determination of the location of survivors or survival craft.

.2. "Embarkation ladder" is the ladder provided at survival craft embarkation stations to permit safe access to survival craft after launching.

.3. "Embarkation station" is the place from which a survival craft is boarded. An embarkation station may also serve as a muster station, provided there is sufficient room, and the muster station activities can safely take place there.

.4. "Float-free launching" is that method of launching a survival craft whereby the craft is automatically released from a sinking craft and is ready for use.

.5. "Free-fall launching" is that method of launching a survival craft whereby the craft with its complement of persons and equipment on board is released and allowed to fall into the sea without any restraining apparatus.

.6. "Immersion suit" is a protective suit which reduces the body heat-loss of a person wearing it in cold water.

.7. "Inflatable appliance" is an appliance which depends upon non-rigid, gas-filled chambers for buoyancy and which is normally kept uninflated until ready for use.

.8. "Inflated appliance" is an appliance which depends upon non-rigid, gas-filled chambers for buoyancy and which is normally kept inflated and ready for use at all times.

.9. "Launching appliance or arrangement" is a means of transferring a survival craft or rescue boat from its stowed position safely to the water.

.10. "Marine evacuation system"(MES) is an appliance designed to rapidly transfer large number of persons from an embarkation station by means of a passage to a floating platform for subsequent embarkation into associated survival craft or directly into associated survival craft.

.11. "Novel life-saving appliance or arrangement" is a life-saving appliance or arrangement which embodies new features not fully covered by the provisions of this chapter but which provides an equal or higher standard of safety.

.12. "Rescue boat" is a boat designed to assist and rescue persons in distress and to marshal survival craft.

.13. "Retrieval" is the safe recovery of survivors.

.14. "Retro-reflective material" is a material which reflects in the opposite direction a beam of light directed on it.

.15. "Survival craft" is a craft capable of sustaining the lives of persons in distress from the time of abandoning the craft.

.16. "Thermal protective aid" is a bag or suit of waterproof material with low thermal conductance.

## 8.2 Communications

8.2.1. Craft should be provided with the following radio life-saving appliances:

.1. at least three two-way VHF radiotelephone apparatus should be provided on every passenger high speed craft and on every cargo high speed craft of 500 tons gross tonnage and upwards. Such apparatus should conform to performance standards not inferior to those adopted by the Organization;

.2. at least one search and rescue locating device shall be carried on each side of every passenger high-speed craft and every cargo high-speed craft of 500 gross tonnage and upwards. Such search and rescue locating device should conform to the applicable performance standards not inferior to those adopted by the Organization. The search and rescue locating device should be stowed in such locations that they can be rapidly placed in any one of the liferafts. Alternatively, one search and rescue locating device should be stowed in each survival craft.

8.2.2. Craft should be provided with the following on-board communications and alarm systems:

.1. an emergency means comprising either fixed or portable equipment or both for two-way communications between emergency control stations, muster and embarkation stations and strategic positions on board; and

.2. a general emergency alarm system complying with the requirements of regulation III/50 of the Convention to be used for summoning passengers and crew to muster stations and to initiate the actions included in the muster list. The system should be supplemented by either a public address system or other suitable means of communication. The systems should be operable from the operating compartment.

8.2.3. Signalling equipment

8.2.3.1. All craft should be provided with a portable daylight signalling lamp which is available for use in the operating compartment at all times and which is not dependent on the craft's main source of electrical power.

8.2.3.2. Craft should be provided with not less than 12 rocket parachute flares, complying with the requirements of regulation III/35 of the Convention, stowed in or near the operating compartment.

## 8.3 Personal life-saving appliances

8.3.1. Where passengers or crew have access to exposed decks under normal operating conditions, at least one lifebuoy on each side of the craft capable of quick release from the control compartment and from a position at or near where it is stowed, should be provided with a self-igniting light and a self-activating smoke signal. The positioning and securing arrangements of the self-activating smoke signal should be such that it cannot be released or activated solely by the accelerations produced by collisions or groundings.

8.3.2. At least one lifebuoy should be provided adjacent to each normal exit from the craft and on each open deck to which passengers and crew have access, subject to a minimum of two being installed.

8.3.3. Lifebuoys fitted adjacent to each normal exit from the craft should be fitted with buoyant lines of at least 30 m in length.

8.3.4. Not less than half the total number of lifebuoys should be fitted with self-igniting lights. However, the lifebuoys provided with self-igniting lights should not include those provided with lines in accordance with 8.3.3.

8.3.5. A lifejacket complying with the requirements of regulation III/32.1 or III/32.2 of the Convention should be provided for every person on board the craft and, in addition:

.1. a number of lifejackets suitable for children equal to at least 10% of the number of passengers on board should be provided or such greater number as may be required to provide a lifejacket for each child;



.2. every passenger craft should carry lifejackets for not less than 5% of the total number of persons on board. These lifejackets should be stowed in conspicuous places on deck or at muster stations;

.3. a sufficient number of lifejackets should be carried for persons on watch and for use at remotely located survival craft and rescue boat stations; and

.4. all lifejackets should be fitted with a light, which complies with the requirements of regulation III/32.3 of the Convention.

8.3.6. Lifejackets should be so placed as to be readily accessible and their positions should be clearly indicated.

8.3.7. An immersion suit, of an appropriate size, complying with the requirements of regulation III/33 of the Convention should be provided for every person assigned to crew the rescue boat.

8.3.8. An immersion suit or anti-exposure suit should be provided for each member of the crew assigned, in the muster list, to duties in an MES party for embarking passengers into survival craft. These immersion suits or anti-exposure suits need not be required if the craft is constantly engaged on voyages in warm climates where, in the opinion of the Administration, such suits are unnecessary.

## **8.4 Muster list, emergency instructions and manuals**

8.4.1. Clear instructions to be followed in the event of an emergency should be provided for each person on board.

8.4.2. Muster lists complying with the requirements of regulation III/53 of the Convention should be exhibited in conspicuous places throughout the craft including the control compartment, engine-room and crew accommodation spaces.

8.4.3. Illustrations and instructions in appropriate languages should be posted in public spaces and be conspicuously displayed at muster stations, at other passenger spaces and near each seat to inform passengers of:

.1. their muster station;

.2. the essential actions they must take in an emergency;

.3. the method of donning lifejackets.

8.4.4. Every passenger craft should have passenger muster stations:

.1. in the vicinity of, and which provide ready access for all the passengers to, the embarkation stations unless in the same location; and

.2. which have ample room for the marshalling and instruction of passengers.

8.4.5. A training manual complying with the requirements of 18.2.3 should be provided in each crew messroom and recreation room.

## **8.5 Operating instructions**

8.5.1. Poster or signs should be provided on or in the vicinity of survival craft and their launching controls and should:

.1. illustrate the purpose of controls and the procedures for operating the appliance and give relevant instructions and warnings:

.2. be easily seen under emergency lighting conditions;

.3. use symbols in accordance with the recommendations of the Organization.

## 8.6 Survival craft stowage

8.6.1. Survival craft should be securely stowed outside and as close as possible to the passenger accommodation and embarkation stations. The stowage should be such that each survival craft can be safely launched in a simple manner and remain secured to the craft during and subsequent to the launching procedure. The length of the securing lines and the arrangements of the bousing lines should be such as to maintain the survival craft suitably positioned for embarkation. The Administrations may permit the use of adjustable securing and/or bousing lines at exits where more than one survival craft is used. The securing arrangements for all securing and bousing lines should be of sufficient strength to hold the survival craft in position during the evacuation process.

8.6.2. Survival craft should be so stowed as to permit release from their securing arrangements at or near to their stowage position on the craft and from a position at or near to the operating compartment.

8.6.3. So far as is practicable, survival craft should be distributed in such a manner that there is an equal capacity on both sides of the craft.

8.6.4. The launching procedure for inflatable liferafts should, where practicable, initiate inflation. Where it is not practicable to provide automatic inflation of liferafts (for example, when the liferafts are associated with an MES), the arrangement should be such that the craft can be evacuated within the time specified in 4.8.1.

8.6.5. Survival craft should be capable of being launched and then boarded from the designated embarkation stations in all operational conditions and also in all conditions of flooding after receiving damage to the extent prescribed in chapter 2.

8.6.6. Survival craft launching stations should be in such positions as to ensure safe launching having particular regard to clearance from the propeller or waterjet and steeply overhanging portions of the hull.

8.6.7. During preparation and launching, the survival craft and the area of water into which it is to be launched should be adequately illuminated by the lighting supplied from the main and emergency sources of electrical power required by chapter 12.

8.6.8. Means should be available to prevent any discharge of water on to survival craft when launched.

8.6.9. Each survival craft should be stowed:

- .1. so that neither the survival craft nor its stowage arrangements will interfere with the operation of any other survival craft or rescue boat at any other launching station;
- .2. in a state of continuous readiness;
- .3. fully equipped; and
- .4. as far as practicable, in a secure and sheltered position and protected from damage by fire and explosion.

8.6.10. Every liferaft should be stowed with its painter permanently attached to the craft and with a float free arrangement complying with the requirements of regulation III/38.6 of the Convention so that, as far as practicable, the liferaft floats free and, if inflatable, inflates automatically should the high speed craft sink.

8.6.11. Rescue boats should be stowed:

- .1. in a state of continuous readiness for launching in not more than 5 min;
- .2. in a position suitable for launching and recovery; and
- .3. so that neither the rescue boat nor its stowage arrangements will interfere with the operation of survival craft at any other launching station.

8.6.12. Rescue boats and survival craft should be secured and fastened to the deck so that they at least withstand the loads likely to arise due to a defined horizontal collision load for the actual craft, and the vertical design load at the stowage position.

## **8.7 Survival craft and rescue boat embarkation and recovery arrangements**

8.7.1. Embarkation stations should be readily accessible from accommodation and work areas. If the designated muster stations are other than the passenger spaces, the muster stations should be readily accessible from the passenger spaces, and the embarkation stations should be readily accessible from the muster stations.

8.7.2. Evacuation routes, exits and embarkation points should comply with the requirements of 4.7.

8.7.3. Alleyways, stairways and exits giving access to the muster and embarkation stations should be adequately illuminated by lighting supplied from the main and emergency source of electrical power required by chapter 12.

8.7.4. Where davit-launched survival craft are not fitted, MES or equivalent means of evacuation should be provided in order to avoid persons entering the water to board survival craft. Such MES or equivalent means of evacuation should be so designed as to enable persons to board survival craft in all operational conditions and also in all conditions of flooding after receiving damage to the extent prescribed in chapter 2.

8.7.5. Subject to survival craft and rescue boat embarkation arrangements being effective within the environmental conditions in which the craft is permitted to operate and in all undamaged and prescribed damage conditions of trim and heel, where the freeboard between the intended embarkation position and the waterline is not more than 1.5 m, the Administration may accept a system where persons board liferafts directly.

8.7.6. Rescue boat embarkation arrangements should be such that the rescue boat can be boarded and launched directly from the stowed position and recovered rapidly when loaded with its full complement of persons and equipment.

8.7.7. A safety knife should be provided at each MES embarkation station.

## **8.8 Line-throwing appliance**

. A line-throwing appliance complying with the requirements of regulation III/49 of the Convention should be provided.

## **8.9 Operational readiness, maintenance and inspections**

### **8.9.1.1. General**

Before the craft leaves port and at all times during the voyage, all life-saving appliances should be in working order and ready for immediate use.

8.9.1.2. Before giving approval to novel life-saving appliances or arrangements, the Administration should ensure that such appliances or arrangements:

.1. provide safety standards at least equivalent to the requirements of this chapter and have been evaluated and tested in accordance with the recommendations of the Organization; or

.2. have successfully undergone, to the satisfaction of the Administration, evaluation and tests which are substantially equivalent to those recommendations.

8.9.1.3. An Administration which permits extension of liferaft service intervals in accordance with 8.9.1.2 should notify the Organization in accordance with regulation I/5(b) of the Convention.

### **8.9.2. Maintenance**

.1. Instructions for on-board maintenance of life-saving appliances complying with the requirements of regulation III/52 of the Convention should be provided and maintenance should be carried out accordingly.

.2. The Administration may accept, in lieu of the instructions required by .1, a shipboard planned maintenance programme which includes the requirements of regulation III/52 of the Convention.

#### 8.9.3. Maintenance of falls

Falls used in launching should be turned end for end at intervals of not more than 30 months and be renewed when necessary due to deterioration of the falls or at intervals of not more than five years, whichever is the earlier.

#### 8.9.4. Spares and repair equipment

Spares and repair equipment should be provided for life-saving appliances and their components which are subject to excessive wear or consumption and need to be replaced regularly.

#### 8.9.5. Weekly inspection

The following tests and inspections should be carried out weekly:

.1. all survival craft, rescue boats and launching appliances should be visually inspected to ensure that they are ready for use;

.2. all engines in rescue boats should be run ahead and astern for a total period of not less than 3 min provided the ambient temperature is above the minimum temperature required for starting the engine;

.3. the general emergency alarm system should be tested.

#### 8.9.6. Monthly inspections

Inspection of the life-saving appliances, including survival craft equipment should be carried out monthly using the checklist required by regulation III/52.1 of the Convention to ensure that they are complete and in good order. A report of the inspection should be entered in the log-book.

#### 8.9.7. Servicing of inflatable liferafts, inflatable lifejackets and inflated rescue boats

.1. Every inflatable liferaft, inflatable lifejacket and MES should be serviced:

.1.1. at intervals not exceeding 12 months, provided where in any case this is impracticable, the Administration may extend this period by one month;

.1.2. at an approved servicing station which is competent to service them, maintains proper servicing facilities and uses only properly trained personnel.

8.9.7.2. In addition to, or in conjunction with, the servicing intervals of marine evacuation systems (MES) required above, each marine evacuation system should be deployed from the craft on a rotational basis at intervals to be agreed by the Administration provided that each system is to be deployed at least once every six years.

8.9.8. All repairs and maintenance of inflated rescue boats should be carried out in accordance with the manufacturer's instructions. Emergency repairs may be carried out on board the craft; however, permanent repairs should be effected at an approved servicing station.

#### 8.9.9. Periodic servicing of hydrostatic release units

Hydrostatic release units should be serviced:

.1. at intervals not exceeding 12 months, provided where in any case this is impracticable, the Administration may extend this period by one month;

.2. at a servicing station which is competent to service them, maintains proper servicing facilities and uses only properly trained personnel.

#### *8.9.10. Periodic servicing of launching appliances*

Launching appliances:

.1. should be serviced at recommended intervals in accordance with instructions for on-board maintenance as required by regulation III/36 of the Convention;

.2. should be subjected to a thorough examination at the annual surveys required by paragraph 1.5.1.3; and

.3. should, upon completion of the examination in .2 above, be subjected to a dynamic test of the winch brake at maximum lowering speed. The load to be applied should be the mass of the survival craft or rescue boat without persons on board, except that, at intervals not exceeding 5 years, the test should be carried out with a proof load equal to 1.1 times the weight of the survival craft or rescue boat and its full complement of persons and equipment.

#### *8.9.11. Novel life-saving appliances or arrangements*

An Administration which approves new and novel inflatable liferaft arrangements pursuant to 8.9.1.2 may allow for extended servicing intervals under the following conditions:

.1. the new and novel liferaft arrangement should maintain the same standard, as required by testing procedures, throughout the extended servicing intervals;

.2. the liferaft system should be checked on board by certified personnel according to 8.7; and

.3. service at intervals not exceeding five years should be carried out in accordance with the recommendations of the Organization.”

8.9.12. An Administration which permits extension of liferaft service intervals in accordance with 8.9.11 should notify the Organization in accordance with regulation I/5(b) of the Convention.

## **8.10 Survival craft and rescue boats**

8.10.1. All craft should carry:

.1. survival craft with sufficient capacity as will accommodate not less than 100% of the total number of persons the craft is certified to carry, subject to a minimum of two such survival craft being carried;

.2. in addition, survival craft with sufficient aggregate capacity to accommodate not less than 10% of the total number of persons the craft is certified to carry;

.3. in the event of any one survival craft being lost or rendered unserviceable, sufficient survival craft to accommodate the total number of persons the craft is certified to carry;

.4. at least one rescue boat for retrieving persons from the water, but not less than one such boat on each side when the craft is certified to carry more than 450 passengers;

.5. craft of less than 20 m in length may be exempted from carrying a rescue boat, provided the craft meets all of the following requirements:

.5.1. the craft is arranged to allow a helpless person to be recovered from the water;

.5.2. recovery of the helpless person can be observed from the navigating bridge; and

.5.3. the craft is sufficiently manoeuvrable to close and recover persons in the worst intended conditions.

.6. notwithstanding provisions of .4 and .5 above, craft should carry sufficient rescue boats to ensure that, in providing for abandonment by the total number of persons the craft is certified to carry:

.6.1. not more than nine of the liferafts provided in accordance with 8.10.1.1 are marshalled by each rescue boat; or

.6.2. if the Administration is satisfied that the rescue boats are capable of towing a pair of such liferafts simultaneously, not more than 12 of the liferafts provided in accordance with 8.10.1.1 are marshalled by each rescue boat; and

.6.3. the craft can be evacuated within the time specified in 4.8.

8.10.2. Where the Administration considers it appropriate, in view of the sheltered nature of the voyages and the suitable climatic conditions of the intended area of operations, the Administration may permit the use of open reversible inflatable liferafts complying with annex 10 on category A craft as an alternative to liferafts complying with regulation III/39 or III/40 of the Convention.

## Chapter 9 – Machinery

### Part A - General

#### 9.1 General

9.1.1. The machinery, associated piping systems and fittings relating to main machinery and auxiliary power units should be of a design and construction adequate for the service for which they are intended and should be so installed and protected as to reduce to a minimum any danger to persons on board, due regard being paid to moving parts, hot surfaces and other hazards. The design should have regard to materials used in construction, the purpose for which the equipment is intended, the working conditions to which it will be subjected and the environmental conditions on board.

9.1.2. All surfaces with temperatures exceeding 220°C where impingement of flammable liquids may occur as a result of a system failure should be insulated. The insulation should be impervious to flammable liquids and vapours.

9.1.3. Special consideration should be given to the reliability of single essential propulsion components and may require a separate source of propulsion power sufficient to give the craft a navigable speed, especially in the case of unconventional arrangements.

9.1.4. Means should be provided whereby normal operation of propulsion machinery can be sustained or restored even though one of the essential auxiliaries becomes inoperative. Special consideration should be given to the malfunctioning of:

.1. a generating set which serves as a main source of electrical power;

.2. the fuel oil supply systems for engines;

.3. the sources of lubricating oil pressure;

.4. the sources of water pressure;

.5. an air compressor and receiver for starting or control purposes;

.6. the hydraulic, pneumatic or electrical means for control in main propulsion machinery including controllable pitch propellers.

However, having regard to overall safety considerations, a partial reduction in propulsion capability from normal operation may be accepted.

9.1.5. Means should be provided to ensure that the machinery can be brought into operation from the dead craft condition without external aid.

9.1.6. All parts of machinery, hydraulic, pneumatic and other systems and their associated fittings which are under internal pressure should be subjected to appropriate tests including a pressure test before being put into service for the first time.

9.1.7. Provision should be made to facilitate cleaning, inspection and maintenance of main propulsion and auxiliary machinery including boilers and pressure vessels.

9.1.8. The reliability of machinery installed in the craft should be adequate for its intended purpose.

9.1.9. The Administration may accept machinery which does not show detailed compliance with the Code where it has been used satisfactorily in a similar application, provided that it is satisfied:

.1. that the design, construction, testing, installation and prescribed maintenance are together adequate for its use in a marine environment; and

.2. that an equivalent level of safety will be achieved.

9.1.10. A failure mode and effect analysis should include machinery systems and their associated controls.

9.1.11. Such information as is necessary to ensure that machinery can be installed correctly regarding such factors as operating conditions and limitations should be made available by the manufacturers.

9.1.12. Main propulsion machinery and all auxiliary machinery essential to the propulsion and the safety of the craft should, as fitted in the craft, be designed to operate when the craft is upright and when inclined at any angle of list up to and including 15° either way under static conditions and 22.5° under dynamic conditions (rolling) either way and simultaneously inclined by dynamically (pitching) 7.5° by bow or stern. The Administration may permit deviation from these angles, taking into consideration the type, size and service conditions of the craft.

9.1.13. All boilers, and pressure vessels and associated piping systems should be of a design and construction adequate for the purpose intended and should be so installed and protected as to minimize danger to persons on board. In particular, attention should be paid to the materials used in the construction and the working pressures and temperatures at which the item will operate and the need to provide an adequate margin of safety over the stresses normally produced in service. Every boiler, pressure vessel and associated piping systems should be fitted with adequate means to prevent over-pressures in service and be subjected to a hydraulic test before being put into service, and where appropriate at subsequent specified intervals, to a pressure suitably in excess of the working pressure.

9.1.14. Arrangements should be provided to ensure that, in the event of failure in any liquid cooling system, it is rapidly detected and alarmed (visual and audible) and means instituted to minimize the effects of such failures on machinery serviced by the system.

## 9.2 Engine (general)

9.2.1. The engines should be fitted with adequate safety monitoring and control devices in respect of speed, temperature, pressure and other operational functions. Control of the machinery should be from the craft's operating compartment. Category B craft and cargo craft should be provided with additional machinery controls in or close to the machinery space. The machinery installation should be suitable for operation as in an unmanned machinery space including automatic fire detection system, bilge alarm system, remote machinery instrumentation and alarm system. Where the space is continuously manned, this requirement may be varied in accordance with the requirements of the Administration.

9.2.2. The engines should be protected against overspeed, loss of lubricating oil pressure, loss of cooling medium, high temperature, malfunction of moving parts and overload. Safety devices should not cause complete engine shutdown without prior warning, except in cases where there is a risk of complete breakdown or explosion. Such safety devices should be capable of being tested.

9.2.3. At least two independent means of stopping the engines quickly from the operating compartment under any operating conditions should be available. Duplication of the actuator fitted to the engine should not be required.

9.2.4. The major components of the engine should have adequate strength to withstand the thermal and dynamic conditions of normal operation. The engine should not be damaged by a limited operation at a speed or at temperatures exceeding the normal values but within the range of the protective devices.

9.2.5. The design of the engine should be such as to minimize the risk of fire or explosion and to enable compliance with the fire precaution requirements of chapter 7.

9.2.6. Provision should be made to drain all excess fuel and oil to a safe position so as to avoid a fire hazard.

9.2.7. Provision should be made to ensure that, whenever practical, the failure of systems driven by the engine should not unduly affect the integrity of the major components.

9.2.8. The ventilation arrangements in the machinery spaces should be adequate under all envisaged operating conditions. Where appropriate, arrangements should ensure that enclosed engine compartments are forcibly ventilated to the atmosphere before the engine can be started.

9.2.9. Any engines should be so installed as to avoid excessive vibration within the craft.

### **9.3 Gas turbines**

9.3.1. Gas turbines should be designed to operate in the marine environment and should be free from surge or dangerous instability throughout its operating range up to the maximum steady speed approved for use. The turbine installation should be arranged to ensure that the turbine cannot be continuously operated within any speed range where excessive vibration, stalling, or surging may be encountered.

9.3.2. The gas turbines should be designed and installed such that any reasonably probable shedding of compressor or turbine blades will not endanger the craft, other machinery, occupants of the craft or any other persons.

9.3.3. Requirements of 9.2.6 should apply to gas turbines in respect of fuel which might reach the interior of the jet pipe or exhaust system after a false start or after stopping.

9.3.4. Turbines should be safeguarded as far as practicable against the possibility of damage by ingestion of contaminants from the operating environment. Information regarding the recommended maximum concentration of contamination should be made available. Provision should be made for preventing the accumulation of salt deposits on the compressors and turbines and, if necessary, for preventing the air intake from icing.

9.3.5. In the event of a failure of a shaft or weak link, the broken end should not hazard the occupants of the craft, either directly or by damaging the craft or its systems. Where necessary, guards may be fitted to achieve compliance with these requirements.

9.3.6. Each engine should be provided with an emergency overspeed shutdown device connected, where possible, directly to each rotor shaft.

9.3.7. Where an acoustic enclosure is fitted which completely surrounds the gas generator and the high pressure oil pipes, a fire detection and extinguishing system should be provided for the acoustic enclosure.

9.3.8. Details of the manufacturers' proposed automatic safety devices to guard against hazardous conditions arising in the event of malfunction in the turbine installation should be provided together with the failure mode and effect analysis.

9.3.9. The manufacturers should demonstrate the soundness of the casings. Intercoolers and heat exchangers should be hydraulically tested on each side separately.

### **9.4 Diesel engines for main propulsion and essential auxiliaries**

9.4.1. Any main diesel propulsion system should have satisfactory torsional vibration and other vibrational characteristics verified by individual and combined torsional and other vibration analyses for the system and its components from power unit through to propulsor.



9.4.2. All external high pressure fuel delivery lines between the high pressure fuel pumps and fuel nozzles should be protected with a jacketed tubing system capable of containing fuel from a high pressure line failure. The jacketed tubing system should include a means for collection of leakages and arrangements should be provided for an alarm to be given of a fuel line failure.

9.4.3. Engines of a cylinder diameter of 200 mm or a crankcase volume of 0.6 m<sup>3</sup> and above should be provided with crankcase explosion relief valves of an approved type with sufficient relief area. The relief valves should be arranged with means to ensure that discharge from them is directed so as to minimize the possibility of injury to personnel.

9.4.4. The lubrication system and arrangements should be efficient at all running speeds, due consideration being given to the need to maintain suction and avoid the spillage of oil in all conditions of list and trim and degree of motion of the craft.

9.4.5. Arrangements should be provided to ensure that visual and audible alarms are activated in the event of either lubricating oil pressure or lubricating oil level falling below a safe level, considering the rate of circulation of oil in the engine. Such events should also cause automatic reduction of engine speed to a safe level, but automatic shutdown should only be activated by conditions leading to a complete breakdown, fire or explosion.

9.4.6. Where diesel engines are arranged to be started, reversed or controlled by compressed air, the arrangement of the air compressor, air receiver and air starting system should be such as to minimize the risk of fire or explosion.

## 9.5 Transmissions

9.5.1. The transmission should be of adequate strength and stiffness to enable it to withstand the most adverse combination of the loads expected in service without exceeding acceptable stress levels for the material concerned.

9.5.2. The design of shafting, bearings and mounts should be such that hazardous whirling and excessive vibration could not occur at any speed up to 105% of the shaft speed attained at the designed overspeed trip setting of the prime mover.

9.5.3. The strength and fabrication of the transmission should be such that the probability of hazardous fatigue failure under the action of the repeated loads of variable magnitude expected in service is extremely remote throughout its operational life. Compliance should be demonstrated by suitably conducted tests, and by designing for sufficiently low stress levels, combined with the use of fatigue resistant materials and suitable detail design. Torsional vibration or oscillation likely to cause failure may be acceptable if it occurs at transmission speeds which would not be used in normal craft operation, and it is recorded in the craft operating manual as a limitation.

9.5.4. Where a clutch is fitted in the transmission, normal engagement of the clutch should not cause excessive stresses in the transmission or driven items. Inadvertent operation of any clutch should not produce dangerously high stresses in the transmission or driven item.

9.5.5. Provision should be made such that a failure in any part of the transmission, or of a driven component, will not cause damage which might hazard the craft or its occupants.

9.5.6. Where failure of lubricating fluid supply or loss of lubricating fluid pressure could lead to hazardous conditions, provision should be made to enable such failure to be indicated to the operating crew in adequate time to enable them as far as practicable to take the appropriate action before the hazardous condition arises.

## 9.6 Propulsion and lift devices

9.6.1. The requirements of this section are based on the premise that:

.1. Propulsion arrangements and lift arrangements may be provided by separate devices, or be integrated into a single propulsion and lift devices. Propulsion devices may be air, or water propellers or water jets and the requirements apply to all types of craft.

.2. Propulsion devices are those which directly provide the propulsive thrust and include machinery items and any associated ducts, vanes, scoops and nozzles, the primary function of which is to contribute to the propulsive thrust.

.3. The lift devices, for the purposes of this section, are those items of machinery which directly raise the pressure of the air and move it for the primary purpose of providing lifting force for an air-cushion vehicle.

9.6.2. The propulsion and lift devices should be of adequate strength and stiffness. The design data, calculations and trials, where necessary, should establish the ability of the device to withstand the loads which can arise during the operations for which the craft is to be certificated, so that the possibility of catastrophic failure is extremely remote.

9.6.3. The design of propulsion and lift devices should pay due regard to the effects of allowable corrosion, electrolytic action between different metals, erosion or cavitation which may result from operation in environments in which they are subjected to spray, debris, salt, sand, icing, etc.

9.6.4. The design data and testing of propulsion and lift devices should pay due regard, as appropriate, to any pressure which could be developed as a result of a duct blockage, to steady and cyclic loadings, to loadings due to external forces and to the use of the devices in manoeuvring and reversing and to the axial location of rotating parts.

9.6.5. Appropriate arrangements should be made to ensure that:

.1. ingestion of debris or foreign matter is minimized;

.2. the possibility of injury to personnel from shafting or rotating parts is minimized; and

.3. where necessary, inspection and removal of debris can be carried out safely in service.

## **Part B - Requirements for Passenger Craft**

### **9.7 Independent means of propulsion for category B craft**

. Category B craft should be provided with at least two independent means of propulsion so that the failure of one engine or its support systems would not cause the failure of the other engine or engine systems and with additional machinery controls in or close to the machinery space.

### **9.8 Means for return to a port of refuge for category B craft**

. Category B craft should be capable of maintaining the essential machinery and control so that, in the event of a fire or other casualties in any one compartment on board, the craft can return to a port of refuge under its own power.

## **Part C - Requirements for Cargo Craft**

### **9.9 Essential machinery and control**

. Cargo craft should be capable of maintaining the essential machinery and control in the event of a fire or other casualties in one of any compartment on board. The craft need not be able to return to a place of refuge under its own power.

## **Chapter 10 - Auxiliary Systems**

### **Part A - General**

#### **10.1 General**

10.1.1. Fluid systems should be constructed and arranged so as to assure a safe and adequate flow of fluid at a prescribed flow rate and pressure under all conditions of craft operation. The probability of a failure or a leakage in any one fluid system causing damage to the electrical system, a fire or an explosion hazard should be extremely remote. Attention should be directed to the avoidance of flammable liquid impingement on hot surfaces in the event of leakage or fracture of the pipe.

10.1.2. The maximum allowable working pressure in any part of the fluid system should not be greater than the design pressure, having regard to the allowable stresses in the materials. Where the maximum allowable working pressure of a system component, such as a valve or a fitting, is less than that computed for the pipe or tubing, the system pressure should be limited to the lowest of the component minimum allowable working pressures. Every system which may be exposed to pressures higher than the system's maximum allowable working pressure should be safeguarded by appropriate relief devices.

10.1.3. Tanks and piping should be pressure tested to a pressure that will assure a safety margin in excess of the working pressure of the item. The test on any storage tank or reservoir should take into account any possible static head in the overflow condition and the dynamic forces arising from craft motions.

10.1.4. Materials used in piping systems should be compatible with the fluid conveyed and selected giving due regard to the risk of fire. Non-metallic piping material may be permitted in certain systems provided the integrity of the hull and watertight decks and bulkheads is maintained.

10.1.5. For the purposes of this chapter, the term "datum" means the datum described in 2.2.1.3.

## **10.2 Arrangement of oil fuel, lubricating oil and other flammable oil**

10.2.1. The provisions of 7.1.2.2 should apply to the use of oil as fuel.

10.2.2. Oil fuel, lubricating oil and other flammable oil lines should be screened or otherwise suitably protected to avoid, as far as practicable, oil spray or oil leakages onto hot surfaces, into machinery air intakes or other sources of ignition. The number of joints in such piping systems should be kept to a minimum. Flexible pipes carrying flammable liquids should be of an approved type.

10.2.3. Fuel oil, lubricating oils and other flammable oils should not be carried forward of public spaces and crew accommodation.

. Oil fuel arrangements

10.2.4. In a craft in which oil fuel is used, the arrangements for the storage, distribution and utilization of the oil fuel should be such as to ensure the safety of the craft and persons on board and should at least comply with the following provisions.

10.2.4.1. As far as practicable, all parts of the oil fuel system containing heated oil under pressure exceeding  $0.18 \text{ N/mm}^2$  should not be placed in a concealed position such that defects and leakage cannot readily be observed. The machinery spaces in way of such parts of the oil fuel system should be adequately illuminated.

10.2.4.2. The ventilation of machinery spaces should be sufficient under all normal conditions to prevent accumulation of oil vapour.

10.2.4.3. Location of fuel tanks should be in accordance with 7.5.2.

10.2.4.4. No oil fuel tank should be situated where spillage or leakage therefrom can constitute a hazard by falling on heated surfaces. Reference is made to the fire safety requirements in 7.5.

10.2.4.5. Oil fuel pipes should be fitted with cocks or valves in accordance with 7.5.3.

10.2.4.6. Every fuel tank should, where necessary, be provided with savealls or gutters to catch any fuel which may leak from such tanks.

10.2.4.7. Safe and efficient means of ascertaining the amount of oil fuel contained in any oil fuel tank should be provided.

10.2.4.7.1. Where sounding pipes are used they should not terminate in any space where the risk of ignition of spillage from the sounding pipe might arise. In particular, they should not terminate in public spaces, crew accommodation or machinery spaces. Terminations should be provided with a suitable means of closure and provision to prevent spillage during refuelling operations.

10.2.4.7.2. Other oil-level gauges may be used in place of sounding pipes. Such means should be subject to the following conditions:

.1. In passenger craft, such means should not require penetration below the top of the tank and their failure or overfilling of the tanks will not permit release of fuel.

.2. The use of cylindrical gauge glasses should be prohibited. In cargo craft, the Administration may permit the use of oil-level gauges with flat glasses and self-closing valves between the gauges and fuel tanks. Such other means should be acceptable to the Administration and should be maintained in the proper condition to ensure their continued accurate functioning in service.

10.2.4.8. Provision should be made to prevent overpressure in any oil tank or in any part of the oil fuel system, including the filling pipes. Any relief valves and air or overflow pipes should discharge to a safe position and, for fuel of flashpoint less than 43°C, should terminate with flame arresters in accordance with the standards developed by the Organization.

10.2.4.9. Oil fuel pipes and their valves and fittings should be of steel or other approved material, except that restricted use of flexible pipes should be permissible in positions where the Administration is satisfied that they are necessary. Such flexible pipes and end attachments should be of approved fire-resisting materials of adequate strength and should be constructed to the satisfaction of the Administration.

#### . Lubricating oil arrangements

10.2.5. The arrangements for the storage, distribution and utilization of oil used in pressure lubrication systems should be such as to ensure the safety of the craft and persons on board. The arrangements made in machinery spaces and, whenever practicable, in auxiliary machinery spaces should at least comply with the provisions of 10.2.4.1 and 10.2.4.4 to 10.2.4.8 except that:

.1. this does not preclude the use of sight-flow glasses in lubricating systems provided they are shown by test to have a suitable degree of fire resistance;

.2. sounding pipes may be permitted in machinery spaces if fitted with appropriate means of closure; and

.3. lubricating oil storage tanks with a capacity of less than 500 l may be permitted without remote operated valves as required in 10.2.4.5.

#### . Arrangements for other flammable oils

10.2.6. The arrangements for storage, distribution and utilization of other flammable oils employed under pressure in power transmission systems, control and activating systems and heating systems should be such as to ensure the safety of the craft and persons on board. In locations where means of ignition are present, such arrangements should at least comply with the provisions of 10.2.4.4 and 10.2.4.7 and with the provisions of 10.2.4.8 and 10.2.4.9 in respect of strength and construction.

#### . Arrangements within machinery spaces

10.2.7. In addition to the requirements of 10.2.1 to 10.2.6, the oil fuel and lubricating oil systems should comply with the following:

10.2.7.1. Where daily service fuel tanks are filled automatically or by remote control, means should be provided to prevent overflow spillages.

10.2.7.2. Other equipment which treats flammable liquids automatically, such as oil fuel purifiers, which, whenever practicable, should be installed in a special space reserved for purifiers and their heaters, should have arrangements to prevent overflow spillages.

10.2.7.3. Where daily service oil fuel tanks or settling tanks are fitted with heating arrangements, a high temperature alarm should be provided if the flashpoint of the oil can be reached due to failure of the thermostatic control.

## 10.3 Bilge pumping and drainage systems

10.3.1. Arrangements should be made for draining any watertight compartment other than the compartments intended for permanent storage of liquid. Where in relation to particular compartments drainage is not considered necessary, drainage arrangements may be omitted but it should be demonstrated that the safety of the craft will not be impaired.

10.3.2. Bilge pumping arrangements should be provided to allow every watertight compartment other than those intended for permanent storage of liquid to be drained. The capacity or position of any such compartment should be such that flooding thereof could not affect the safety of the craft.

10.3.3. The bilge pumping system should be capable of operation under all possible values of list and trim after the craft has sustained the postulated damage in 2.6.5 and 2.6.8. The bilge pumping system should be so designed as to prevent water flowing from one compartment to another. The necessary valves for controlling the bilge suction should be capable of being operated from above the datum. All distribution boxes and manually operated valves in connection with the bilge pumping arrangements should be in positions which are accessible under ordinary circumstances.

10.3.4. The power operated self-priming bilge pumps may be used for other duties such as fire fighting or general service but not for pumping fuel or other flammable liquids.

10.3.5. Each power bilge pump should be capable of pumping water through the required bilge pipe at a speed of not less than 2 m/s.

10.3.6. The diameter (d) of the bilge main should be calculated according to the following formula, except that the actual internal diameter of the bilge main may be rounded off to the nearest size of a recognized standard:

$$d = 25 + 1.68(L(B + D))^{0.5}$$

where:

d is the internal diameter of the bilge main (mm);

L is the length of the craft (m) as defined in chapter 1:

B is for monohull craft, the breadth of the craft in m as defined in chapter 1 and for multihull craft, the breadth of a hull at or below the design waterline (m); and

D is the moulded depth of the craft to the datum (m).

10.3.7. Internal diameters of suction branches should meet the requirements of the Administration but should not be less than 25 mm. Suction branches should be fitted with effective strainers.

10.3.8. An emergency bilge suction should be provided for each machinery space containing a propulsion prime mover. This suction should be led to the largest available power pump other than a bilge pump, propulsion pump or oil pump.

10.3.9. The spindles of the sea inlet valves should extend well above the machinery space floor plates.

10.3.10. All bilge suction piping up to the connection to the pumps should be independent of other piping.

10.3.11. Spaces situated above the water level in the worst anticipated damage conditions may be drained directly overboard through scuppers fitted with non-return valves.

10.3.12. Any unattended space for which bilge pumping arrangements are required should be provided with a bilge alarm.

10.3.13. For craft with individual bilge pumps, the total capacity Q of the bilge pumps for each hull should not be less than 2.4 times the capacity of the pump defined in 10.3.5 and 10.3.6.

10.3.14. In bilge pumping arrangements where a bilge main is not provided then, with the exception of the spaces forward of public spaces and crew accommodation, at least one fixed submersible pump should be provided for each space. In addition, at least one portable pump should be provided supplied from the emergency supply, if electric, for use on individual spaces. The capacity of each submersible pump  $Q_n$  should not be less than:

.  $Q_n = Q/(N-1)$  tonne/h with a minimum of 8 tonnes/h

where: N = number of submersible pumps

. Q = total capacity as defined in 10.3.13.

10.3.15. Non-return valves should be fitted in the following components:

- .1. bilge valve distribution manifolds;
- .2. bilge suction hose connections where fitted directly to the pump or to the main bilge suction pipe; and
- .3. direct bilge suction pipes and bilge pump connections to main bilge suction pipe.

## 10.4 Ballast systems

10.4.1. Water ballast should not in general be carried in tanks intended for oil fuel. In craft in which it is not practicable to avoid putting water in oil fuel tanks, oily-water separating equipment should be fitted, or other alternative means such as discharge to shore facilities should be provided for disposing of the oily-water ballast. The provisions of this paragraph are without prejudice to the provisions of the International Convention for the Prevention of Pollution from Ships in force.

10.4.2. Where a fuel transfer system is used for ballast purposes, the system should be isolated from any water ballast system and meet the requirements for fuel systems and the International Convention for the Prevention of Pollution from Ships in force.

## 10.5 Cooling systems

. The cooling arrangements provided should be adequate to maintain all lubricating and hydraulic fluid temperatures within manufacturers' recommended limits during all operations for which the craft is to be certificated.

## 10.6 Engine air intake systems

. Arrangements should provide sufficient air to the engine and should give adequate protection against damage as distinct from deterioration, due to ingress of foreign matter.

## 10.7 Ventilation systems

. Machinery spaces should be adequately ventilated so as to ensure that when machinery therein is operating at full power in all weather conditions including heavy weather, an adequate supply of air is maintained to the spaces for the safety and comfort of personnel and the operation of the machinery. Auxiliary machinery spaces should be adequately ventilated appropriate for the purpose of those spaces. The ventilation arrangements should be adequate to ensure that the safe operation of the craft is not put at risk.

## 10.8 Exhaust systems

10.8.1. All engines exhaust systems should be adequate to assure the correct functioning of the machinery and that safe operation of the craft is not put at risk.

10.8.2. Exhaust systems should be so arranged as to minimize the intake of exhaust gases into manned spaces, air-conditioning systems, and engine intakes. Exhaust systems should not discharge into air cushion intakes.

10.8.3. Pipes through which exhaust gases are discharged through the hull in the vicinity of the waterline should be fitted with erosion/corrosion resistant shut-off flaps or other devices on the shell or pipe end and acceptable arrangements made to prevent water flooding the space or entering the engine exhaust manifold.

10.8.4. Gas turbine engine exhausts should be arranged so that hot exhaust gases are directed away from areas to which personnel have access, either on board the craft or in the vicinity of the craft when berthed.

## **Part B - Requirements for Passenger Craft**

### **10.9 Bilge pumping and drainage systems**

*10.9.1.* For category B craft at least three and for category A craft at least two power bilge pumps should be fitted connected to the bilge main, one of which may be driven by the propulsion machinery. Alternatively, the arrangement may be in accordance with the requirements of 10.3.14.

*10.9.2.* The arrangements should be such that at least one power bilge pump should be available for use in all flooding conditions which the craft is required to withstand as follows:

.1. one of the required bilge pumps should be an emergency pump of a reliable submersible type having an emergency source of power; or

.2. the bilge pumps and their sources of power should be so distributed throughout the length of the craft that at least one pump in an undamaged compartment will be available.

*10.9.3.* On multihull craft, each hull should be provided with at least two bilge pumps.

*10.9.4.* Distribution boxes, cocks and valves in connection with the bilge pumping system should be so arranged that, in the event of flooding, one of the bilge pumps may be operative in any compartment. In addition, damage to a pump or its pipe connecting to the bilge main should not put the bilge system out of action. When, in addition to the main bilge pumping system, an emergency bilge pumping system is provided, it should be independent of the main system and so arranged that a pump is capable of operating in any compartment under flooding conditions as specified in 10.3.3. In that case only the valves necessary for the operation of the emergency system need be capable of being operated from above the datum.

*10.9.5.* All cocks and valves referred to in 10.9.4 which can be operated from above the datum should have their controls at their place of operation clearly marked and should be provided with means to indicate whether they are open or closed.

## **Part C - Requirements for Cargo Craft**

### **10.10 Bilge pumping systems**

*10.10.1.* At least two power pumps connected to the main bilge system should be provided, one of which may be driven by the propulsion machinery. If the Administration is satisfied that the safety of the craft is not impaired, bilge pumping arrangements may be dispensed with in particular compartments. Alternatively, the arrangement may be in accordance with the requirements of 10.3.14.

*10.10.2.* On multihull craft each hull should be provided with at least two power pumps, unless a bilge pump in one hull is capable of pumping bilge in the other hull. At least one pump in each hull should be an independent power pump.

## **Chapter 11 - Remote Control, Alarm and Safety Systems**

### **11.1 Definitions**

*11.1.1.* "Remote control systems" comprise all equipment necessary to operate units from a control position where the operator cannot directly observe the effect of his actions.

*11.1.2.* "Back-up control systems" comprise all equipment necessary to maintain control of essential functions required for the craft's safe operation when the main control systems have failed or malfunctioned.

### **11.2 General**

*11.2.1.* Failure of any remote or automatic control systems should initiate an audible and visual alarm and should not prevent normal manual control.

11.2.2. Manoeuvring and emergency controls should permit the operating crew to perform the duties for which they are responsible in a correct manner without difficulty, fatigue or excessive concentration.

11.2.3. Where control of propulsion or manoeuvring is provided at stations adjacent to but outside the operating compartment, the transfer of control should only be effected from the station which takes charge of control. Two-way voice communication should be provided between all stations from which control functions may be exercised and between each such station and the look-out position. Failure of the operating control system or of transfer of control should bring the craft to low speed without hazarding passengers or the craft.

11.2.4. For category B craft and cargo craft, remote control systems for propulsion machinery and directional control should be equipped with back-up systems controllable from the operating compartment. For cargo craft, instead of a back-up system described above, a back-up system controllable from an engine control space such as an engine control room outside the operating compartment is acceptable.

## 11.3 Emergency controls

11.3.1. In all craft, the station or stations in the operating compartment from which control of craft manoeuvring and/or of its main machinery is exercised should be provided, within easy reach of the crew member at that station, with controls for use in an emergency to:

- .1. activate fixed fire-extinguishing systems:
- .2. close ventilation openings and stop ventilating machinery supplying spaces covered by fixed fire-extinguishing systems, if not incorporated in .1:
- .3. shut off fuel supplied to machinery in main and auxiliary machinery spaces:
- .4. disconnect all electrical power sources from the normal power distribution system (the operating control should be guarded to reduce the risk of inadvertent or careless operation); and
- .5. stop main engine(s) and auxiliary machinery.

11.3.2. Where control of propulsion and manoeuvring is provided at stations outside the operating compartment, such stations should have direct communication with the operating compartment which should be a continuously manned control station.

## 11.4 Alarm system

11.4.1. Alarm systems should be provided which announce at the craft's control position, by visual and audible means, malfunctions or unsafe conditions. Alarms should be maintained until they are accepted and the visual indications of individual alarms should remain until the fault has been corrected, when the alarm should automatically reset to the normal operating condition. If an alarm has been accepted and a second fault occurs before the first is rectified, the audible and visual alarms should operate again. Alarm systems should incorporate a test facility.

11.4.1.1. Alarms giving indication of conditions requiring immediate action should be distinctive and in full view of crew members in the operating compartment, and should be provided for the following:

- .1. activation of a fire detection system;
- .2. total loss of normal electrical supply;
- .3. overspeed of main engines;
- .4. thermal runaway of any permanently installed nickel-cadmium battery.

11.4.1.2. Alarms with a visual display distinct from that of alarms referred to in 11.4.1.1 should indicate conditions requiring action to prevent degradation to an unsafe condition. These should be provided for at least the following:



- .1. exceeding the limiting value of any craft, machinery or system parameter other than engine over speed;
- .2. failure of normal power supply to powered directional or trim control devices;
- .3. operation of any automatic bilge pump;
- .4. failure of compass system;
- .5. low level of a fuel tank contents;
- .6. fuel oil tank overflow;
- .7. extinction of side, masthead or stern navigation lights;
- .8. low level of contents of any fluid reservoir the contents of which are essential for normal craft operation;
- .9. failure of any connected electrical power source;
- .10. failure of any ventilation fan installed for ventilating spaces in which inflammable vapours may accumulate;
- .11. diesel engine fuel line failure as required by 9.4.2.

11.4.1.3. All warnings required by 11.4.1.1 and 11.4.1.2 should be provided at all stations at which control functions may be exercised.

11.4.2. The alarm system should meet appropriate constructional and operational requirements for required alarms .

11.4.3. Equipment monitoring the passenger, cargo and machinery spaces for fire and flooding should, so far as is practicable, form an integrated sub-centre incorporating monitoring and activation controls for all emergency situations. This sub-centre may require feed-back instrumentation to indicate that actions initiated have been fully implemented.

## **11.5 Safety system**

. Where arrangements are fitted for overriding any automatic shutdown system for the main propulsion machinery in accordance with 9.2.2, they should be such as to preclude inadvertent operation. When a shutdown system is activated, an audible and visual alarm should be given at the control station and means should be provided to override the automatic shutdown except in cases where there is a risk of complete breakdown or explosion.

## **Chapter 12 - Electrical Installations**

### **Part A - General**

#### **12.1 General**

12.1.1. Electrical installations should be such that:

- .1. all electrical auxiliary services necessary for maintaining the craft in normal operation and habitable conditions will be ensured without recourse to the emergency source of electrical power;
- .2. electrical services essential for safety will be ensured under various emergency conditions, and
- .3. the safety of passengers, crew and craft from electrical hazards will be ensured.

The FMEA should include the electrical system, taking into account the effects of electrical failure on the systems being supplied. In cases where faults can occur without being detected during routine checks on the installations, the analysis should take into account the possibility of faults occurring simultaneously or consecutively.

12.1.2. The electrical system should be designed and installed so that the probability of the craft being at risk of failure of a service is extremely remote.

12.1.3. Where loss of particular essential service would cause serious risk to the craft, the service should be fed by at least two independent circuits fed in such a way that no single failure in the electrical supply or distribution systems would effect both supplies.

12.1.4. The securing arrangements for heavy items, i.e. accumulator batteries, should, as far as practicable, prevent excessive movement during the accelerations due to grounding or collision.

12.1.5. Precautions should be taken to minimize risk of supplies to essential and emergency services being interrupted by the inadvertent or accidental opening of switches or circuit breakers.

## **12.2 Main source of electrical power**

12.2.1. A main source of electrical power of sufficient capacity to supply all those services mentioned in 12.1.1 should be provided. The main source of electrical power should consist of at least two generating sets.

12.2.2. The capacity of these generating sets should be such that in the event of any one generating set being stopped or failing it will still be possible to supply those services necessary to provide the normal operational conditions of propulsion and safety. Minimum comfortable conditions of habitability should also be ensured which include at least adequate services for cooking, heating, domestic refrigeration, mechanical ventilation, sanitary and fresh water.

12.2.3. The arrangements of the craft's main source of electrical power should be such that the services referred to in 12.1.1.1 can be maintained regardless of the speed and direction of the propulsion machinery or shafting.

12.2.4. In addition, the generating sets should be such as to ensure that with any one generator or its primary source of power out of operation, the remaining generating set should be capable of providing the electrical services necessary to start the main propulsion plant from dead craft condition. The emergency source of electrical power may be used for the purpose of starting from a dead craft condition if its capability either alone or combined with that of any other source of electrical power is sufficient to provide at the same time those services required to be provided by 12.7.3.1 to 12.7.3.3 or 12.7.4.1 to 12.7.4.4 or 12.8.2.1 to 12.8.2.4.1, as appropriate.

12.2.5. Where transformers constitute an essential part of the electrical supply system required by this section, the system should be so arranged as to ensure the same continuity of supply as is stated in 12.2.

12.2.6. A main electric lighting system which should provide illumination throughout those parts of the craft normally accessible to and used by passengers and crew should be supplied from the main source of electrical power.

12.2.7. The arrangement of the main electric lighting system should be such that a fire or other casualty in spaces containing the emergency source of electrical power, associated transforming equipment, if any, the emergency switchboard and the emergency lighting switchboard will not render inoperative the main electric lighting system required by 12.2.6.

12.2.8. The main switchboard should be so placed relative to one main generating station that, as far as practicable, the integrity of the normal electrical supply may be affected only by a fire or other casualty in one space. An environmental enclosure for the main switchboard, such as may be provided by a machinery control room situated within the main boundaries of the space, should not be considered as separating the switchboards from the generators.

12.2.9. The main busbars should normally be subdivided into at least two parts which should be connected by a circuit-breaker or other approved means. So far as is practicable, the connection of generating sets and any other duplicated equipment should be equally divided between the parts. Equivalent arrangements may be permitted to the satisfaction of the Administration.

## **12.3 Emergency source of electrical power**

12.3.1. A self-contained emergency source of electrical power should be provided.

12.3.2. The emergency source of electrical power, associated transforming equipment, if any, transitional source of electrical power, emergency switchboard and emergency lighting switchboard should be located above the waterline in the final condition of damage as referred to in chapter 2, operable in that condition and readily accessible.

12.3.3. The location of the emergency source of electrical power and associated transforming equipment, if any, the transitional source of emergency power, the emergency switchboard and the emergency electrical lighting switchboards in relation to the main source of electrical power, associated transforming equipment, if any, and the main switchboard should be such as to ensure that a fire or other casualty in spaces containing the main source of electrical power, associated transforming equipment, if any, and the main switchboard or in any machinery space will not interfere with the supply, control and distribution of emergency electrical power. As far as practicable, the space containing the emergency source of electrical power, associated transforming equipment, if any, the transitional source of emergency electrical power and the emergency switchboard should not be contiguous to the boundaries of main machinery spaces or those spaces containing the main source of electrical power, associated transforming equipment, if any, or the main switchboard.

12.3.4. Provided that suitable measures are taken for safeguarding independent emergency operation under all circumstances, the emergency generator, if provided, may be used exceptionally, and for short periods, to supply non-emergency circuits.

12.3.5. Distribution systems should be so arranged that the feeders from the main and emergency sources are separated both vertically and horizontally as widely as practicable.

12.3.6. The emergency source of electrical power may be either a generator or an accumulator battery, which should comply with the following:

.1. Where the emergency source of electrical power is a generator, it should be:

.1.1. driven by a suitable prime mover with an independent supply of fuel having a flashpoint which meets the requirements of 7.1.2.2;

.1.2. started automatically upon failure of the electrical supply from the main source of electrical power and should be automatically connected to the emergency switchboard. Those services referred to in 12.7.5 or 12.8.3 should then be transferred to the emergency generating set. The automatic starting system and the characteristic of the prime mover should be such as to permit the emergency generator to carry its full rated load as quickly as is safe and practicable, subject to a maximum of 45 s; and

.1.3. provided with a transitional source of emergency electrical power according to 12.7.5 or 12.8.3.

.2. Where the emergency source of electrical power is an accumulator battery, it should be capable of:

.2.1. carrying the emergency electrical load without recharging while maintaining the voltage of the battery throughout the discharge period within 12% above or below its nominal voltage;

.2.2. automatically connecting to the emergency switchboard in the event of failure of the main source of electrical power; and

.2.3. immediately supplying at least those services specified in 12.7.5 or 12.8.3.

12.3.7. The emergency switchboard should be installed as near as is practicable to the emergency source of electrical power.

12.3.8. Where the emergency source of electrical power is a generator, the emergency switchboard should be located in the same space unless the operation of the emergency switchboard would thereby be impaired.

12.3.9. No accumulator battery fitted in accordance with this section should be installed in the same space as the emergency switchboard. An indicator should be mounted in a suitable space at the craft's operating compartment to indicate when the batteries constituting either the emergency source of electrical power or the transitional source of emergency electrical power referred to in 12.3.6.1.3 are being discharged.

12.3.10. The emergency switchboard should be supplied during normal operation from the main switchboard by an interconnector feeder which should be adequately protected at the main switchboard against overload and short circuit and which should be disconnected automatically at the emergency switchboard upon failure of the main source of electrical power. Where the system is arranged for feedback operation, the interconnector feeder should also be protected at the emergency switchboard at least against short circuit. Failure of the emergency switchboard, when being used in other than an emergency, should not put at risk the operation of the craft.

12.3.11. In order to ensure ready availability of the emergency source of electrical power, arrangements should be made, where necessary, to disconnect automatically non-emergency circuits from the emergency switchboard to ensure that power should be available to the emergency circuits.

12.3.12. The emergency generator and its prime mover and any emergency accumulator battery should be so designed and arranged as to ensure that they will function at full rated power when the craft is upright and when the craft has a list or trimming accordance with 9.1.12 including any damage cases considered in chapter 2, or is in any combination of angles within those limits.

12.3.13. Where accumulator batteries are installed to supply emergency services, provisions should be made to charge them in situ from a reliable on-board supply. Charging facilities should be designed to permit the supply of services, regardless of whether battery is on charge or not. Means should be provided to minimize the risk of overcharging or overheating the batteries. Means for efficient air ventilation should be provided.

## **12.4 Starting arrangements for emergency generating sets**

12.4.1. Emergency generating sets should be capable of being readily started in their cold condition at a temperature of 0°C. If this is impracticable, or if lower temperatures are likely to be encountered, provisions should be made for heating arrangements to ensure ready starting of the generating sets.

12.4.2. Each emergency generating set should be equipped with starting devices with a stored energy capability of at least three consecutive starts. The source of stored energy should be protected to preclude critical depletion by the automatic starting system, unless a second independent means of starting is provided. A second source of energy should be provided for an additional three starts within 30 min, unless manual starting can be demonstrated to be effective.

12.4.3. The stored energy should be maintained at all times, as follows:

- .1. electrical and hydraulic starting systems should be maintained from the emergency switchboard;
- .2. compressed air starting systems may be maintained by the main or auxiliary compressed air receivers through a suitable non-return valve or by an emergency air compressor which, if electrically driven, is supplied from the emergency switchboard;
- .3. all of these starting, charging and energy storing devices should be located in the emergency generator space. These devices should not be used for any purpose other than the operation of the emergency generating set. This does not preclude the supply to the air receiver of the emergency generating set from the main or auxiliary compressed air system through the non-return valve fitted in the emergency generator space.

## **12.5 Steering and stabilization**

12.5.1. Where steering and/or stabilization of a craft is essentially dependent on one device as with a single rudder or pylon, which is itself dependent on the continuous availability of electric power, it should be served by at least two independent circuits one of which should be fed either from the emergency source of electric power or from an independent power source located in such a position as to be unaffected by fire or flooding affecting the main source of power. Failure of either supply should not cause any risk to the craft or passengers during switching to the alternative supply and such switching arrangements should meet the requirements in 5.2.5. These circuits should be provided with short circuit protection and an overload alarm.

12.5.2. Protection against excess current may be provided, in which case it should be for not less than twice the full load current of the motor or circuit so protected, and should be arranged to accept the appropriate starting current with a reasonable margin. Where three-phase supply is used, an alarm should be provided in a readily observed position in the craft's operating compartment that will indicate failure of any one of the phases.

12.5.3. Where such systems are not essentially dependent on the continuous availability of electric power but at least one alternative system, not dependent on the electric supply is installed, then the electrically powered or controlled system may be fed by a single circuit protected in accordance with 12.5.2.

12.5.4. The requirements of chapters 5 and 16 for power supply of the directional control system and stabilization system of the craft should be met.

## **12.6 Precautions against shock, fire and other hazards of electrical origin**

12.6.1.1. Exposed metal parts of electrical machines or equipment which are not intended to be live but which are liable under fault conditions to become live should be earthed unless the machines or equipment are:

.1. supplied at a voltage not exceeding 55 V direct current or 55 V root mean square between conductors; auto-transformers should not be used for the purpose of achieving this voltage; or

.2. supplied at a voltage not exceeding 250 V by safety isolating transformers supplying only one consuming device; or

.3. constructed in accordance with the principle of double insulation.

12.6.1.2. The Administration may require additional precautions for portable electrical equipment for use in confined or exceptionally damp spaces where particular risks due to conductivity may exist.

12.6.1.3. All electrical apparatus should be so constructed and so installed as not to cause injury when handled or touched in the normal manner.

12.6.2. Main and emergency switchboards should be so arranged as to give easy access, as may be needed, to apparatus and equipment, without danger to personnel. The sides and the rear and, where necessary, the front of switchboards should be suitably guarded. Exposed live parts having voltages to earth exceeding a voltage to be specified by the Administration should not be installed on the front of such switchboards. Where necessary, nonconducting mats or gratings should be provided at the front and rear of the switchboard.

12.6.3. When a distribution system, whether primary or secondary, for power, heating or lighting, with no connection to earth is used, a device capable of continuously monitoring the insulation level to earth and of giving an audible or visual indication of abnormally low insulation values should be provided. For limited secondary distribution systems the Administration may accept a device for manual checking of the insulation level.

### **12.6.4 Cables and wiring**

12.6.4.1. Except as permitted by the Administration in exceptional circumstances, all metal sheaths and armour of cables should be electrically continuous and should be earthed.

12.6.4.2. All electric cables and wiring external to equipment should be at least of a flame-retardant type and should be so installed as not to impair their original flame-retarding properties. Where necessary for particular applications, the Administration may permit the use of special types of cables such as radio frequency cables, which do not comply with the foregoing.

12.6.4.3. Cables and wiring serving essential or emergency power, lighting, internal communications or signals should so far as practicable be routed clear of machinery spaces and their casings and other high fire risk areas. Where practicable all such cables should be run in such a manner as to preclude their being rendered unserviceable by heating of the bulkheads that may be caused by a fire in an adjacent space.

12.6.4.4. Where cables which are installed in hazardous areas introduce the risk of fire or explosion in the event of an electrical fault in such areas, special precautions against such risks should be taken to the satisfaction of the Administration.

12.6.4.5. Cables and wiring should be installed and supported in such manner as to avoid chafing or other damage.

12.6.4.6. Terminations and joints in all conductors should be so made as to retain the original electrical, mechanical, flame-retarding and, where necessary, fire-resisting properties of the cable.

12.6.5.1. Each separate circuit should be protected against short circuit and against overload, except as permitted in 12.5, or where the Administration may exceptionally otherwise permit.

12.6.5.2. The rating or appropriate setting of the overload protective device for each-circuit should be permanently indicated at the location of the protective device.

12.6.5.3. When the protective device is a fuse it should be placed on the load side of the disconnect switch serving the protected circuit.

12.6.6. Lighting fittings should be so arranged as to prevent temperature rises which could damage the cables and wiring, and to prevent surrounding material from becoming excessively hot.

12.6.7. All lighting and power circuits terminating in a bunker or cargo space should be provided with a multiple-pole switch outside the space for disconnecting such circuits.

12.6.8.1. Accumulator batteries should be suitably housed, and compartments used primarily for their accommodation should be properly constructed and efficiently ventilated.

12.6.8.2. Electrical or other equipment which may constitute a source of ignition of flammable vapours should not be permitted in these compartments except as permitted in 12.6.9.

12.6.8.3. Accumulator batteries should not be located in crew accommodation.

12.6.9. No electrical equipment should be installed in any space where flammable mixtures are liable to collect including those in compartments assigned principally to accumulator batteries, in paint lockers, acetylene stores or similar spaces, unless the Administration is satisfied that such equipment is:

- .1. essential for operational purposes;
- .2. of a type which will not ignite the mixture concerned;
- .3. appropriate to the space concerned; and
- .4. appropriately certified for safe usage in the dusts, vapours or gases likely to be encountered.

12.6.10. The following additional requirements from .1 to .7 should be met, and requirements from .8 to .13 should be met also for non-metallic craft:

.1. The electrical distribution voltages throughout the craft may be either direct current or alternating current and should not exceed:

- .1.1. 500 V for power, cooking, heating and other permanently connected equipment; and
- .1.2. 250 V for lighting, internal communications and receptacle outlets.

The Administration may accept higher voltage for propulsion purposes.

.2. For electrical power distribution, two-wire, three-wire or four-wire insulated systems should be used. Where applicable, the requirements of 7.5.6.4 or 7.5.6.5 should also be met.

.3. Effective means should be provided so that voltage may be cut off from each and every circuit and sub-circuit and from all apparatus as may be necessary to prevent danger.

.4. Electrical equipment should be so designed that the possibility of accidentally touching live parts, rotating or moving parts as well as heated surfaces which might cause burns or initiate fire is minimized.

.5. Electrical equipment should be adequately secured. The probability of fire or dangerous consequences arising from damage to electrical equipment should be reduced to an acceptable minimum.

.6. The rating or appropriate setting of the overload protective device for each circuit should be permanently indicated at the location of the protection device.

.7. Where it is impracticable to provide electrical protective devices for certain cables supplied from batteries, e.g. within battery compartments and in engine starting circuits, unprotected cable runs should be kept as short as possible and special precautions should be taken to minimize risk of faults, e.g. use of single core cables with additional sleeve over the insulation of each core, with shrouded terminals.

.8. In order to minimize the risk of fire, structural damage, electrical shock and radio interference due to lightning strike or electrostatic discharge, all metal parts of the craft should be bonded together, in so far as possible in consideration of galvanic corrosion between dissimilar metals, to form a continuous electrical system, suitable for the earth return of electrical equipment and to connect the craft to the water when water-borne. The bonding of isolated components inside the structure is not generally necessary, except in fuel tanks.

.9. Each pressure refuelling point should be provided with a means of bonding the fuelling equipment to the craft.

.10. Metallic pipes capable of generating electrostatic discharges, due to the flow of liquids and gases should be bonded so as to be electrically continuous throughout their length and should be adequately earthed.

.11. Primary conductors provided for lightning discharge currents should have a minimum cross section of 50 mm<sup>2</sup> in copper or equivalent surge carrying capacity in aluminium.

.12. Secondary conductors provided for the equalization of static discharges, bonding of equipment, etc., but not for carrying lightning discharges should have a minimum cross section of 5 mm<sup>2</sup> copper or equivalent surge current carrying capacity in aluminium.

.13. The electrical resistance between bonded objects and the basic structure should not exceed 0.05 Ohms except where it can be demonstrated that a higher resistance will not cause a hazard. The bonding path should have sufficient cross-sectional area to carry the maximum current likely to be imposed on it without excessive voltage drop.

## **Part B - Requirements for Passenger Craft**

### **12.7 General**

12.7.1. Separation and duplication of electrical supply should be provided for duplicated consumers of essential services. During normal operation the systems may be connected to the same power-bus, but facilities for easy separation should be provided. Each system should be able to supply all equipment necessary to maintain the control of propulsion, steering, stabilization, navigation, lighting and ventilation, and allow starting of the largest essential electric motor at any load. Automatic load-dependent disconnection of non-essential consumers may be allowed.

#### 12.7.2. Emergency source of electrical power

Where the main source of electrical power is located in two or more compartments which are not contiguous, each of which has its own self-contained systems, including power distribution and control systems, completely independent of each other and such that a fire or other casualty in any one of the spaces will not affect the power distribution from the others, or to the services required by 12.7.3 or 12.7.4, the requirements of 12.3.1, 12.3.2 and 12.3.4 may be considered satisfied without an additional emergency source of electrical power, provided that:

.1. there is at least one generating set, meeting the requirements of 12.3.12 and of sufficient capacity to meet the requirements of 12.7.3 or 12.7.4 in each of at least two non-contiguous spaces;

.2. the arrangements required by .1 in each such space are equivalent to those required by 12.3.6.1, 12.3.7 to 12.3.11 and 12.4 so that a source of electrical power is available at all times to the services required by or 12.7.4: and

.3. the generator sets referred to in .1 and their self-contained systems are installed such that one of them remains operable after damage or flooding in any one compartment.

12.7.3. For category A craft, the emergency source of power should be capable of supplying simultaneously the following services:

.1. for a period of 5 h emergency lighting:

.1.1. at the stowage positions of life-saving appliances;

.1.2. at all escape routes such as alleyways, stairways, exits from accommodation and service spaces, embarkation points, etc;

.1.3. in the public spaces;

.1.4. in the machinery spaces and main emergency generating spaces including their control positions;

.1.5. in control stations;

.1.6. at the stowage positions for firemen's outfits; and

.1.7. at the steering gear:

.2. for a period of 5 h:

.2.1. main navigation lights, except for "not under command" lights:

.2.2. electrical internal communication equipment for announcements for passengers and crew required during evacuation;

.2.3. fire detection and general alarm system and manual fire alarms; and

.2.4. remote control devices of fire-extinguishing systems, if electrical;

.3. for a period of 4 h of intermittent operation:

.3.1. the daylight signalling lamps, if they have no independent supply from their own accumulator battery; and

.3.2. the craft's whistle, if electrically driven;

.4. for a period of 5 h:

.4.1. craft radio facilities and other loads as set out in 14.12.2; and

.4.2. essential electrically powered instruments and controls for propulsion machinery, if alternate sources of power are not available for such devices;

.5. for a period of 12 h, the "not under command" lights; and

.6. for a period of 10 min:

.6.1. power drives for directional control devices including those required to direct thrust forward and astern, unless there is a manual alternative acceptable to the Administration as complying with 5.2.3.

12.7.4. For category B craft, the electrical power available should be sufficient to supply all those services that are essential for safety in an emergency, due regard being paid to such services as may have to be operated simultaneously. The emergency source of electrical power should be capable, having regard to starting currents



and the transitory nature of certain loads, of supplying simultaneously at least the following services for the periods specified hereinafter, if they depend upon an electrical source for their operation.

.1. for a period of 12 h, emergency lighting:

.1.1. at the stowage positions of life-saving appliances;

.1.2. at all escape routes, such as alley ways, stairways, exits from accommodation and service spaces, embarkation points, etc;

.1.3. in the passenger compartments;

.1.4. in the machinery spaces and main emergency generating spaces including their control positions;

.1.5. in control stations:

.1.6. at the stowage positions for firemen's outfits; and

.1.7. at the steering gear.

.2. for a period of 12 h:

.2.1. the navigation lights and other lights required by the International Regulations for Preventing Collisions at Sea in force;

.2.2. electrical internal communication equipment for announcements for passengers and crew required during evacuation;

.2.3. fire detection and general alarm system and manual fire alarms; and

.2.4. remote control devices of fire-extinguishing systems, if electrical;

.3. for a period of 4 h on intermittent operation:

.3.1. the daylight signalling lamps, if they have no independent supply from their own accumulator battery; and

.3.2. the craft's whistle, if electrically driven;

.4. .4 for a period of 12 h:

.4.1. the navigational equipment as required by chapter 13. Where such provision is unreasonable or impracticable, the Administration may waive this requirement for craft of less than 5,000 tons gross tonnage;

.4.2. essential electrically powered instruments and controls for propulsion machinery, if alternate sources of power not available for such devices;

.4.3. one of the fire pumps required by 7.7.8.1;

.4.4. the sprinkler pump and drencher pump, if fitted;

.4.5. the emergency bilge pump and all the equipment essential for the operation of electrically powered remote controlled bilge valves as required by chapter 10, and

.4.6. craft radio facilities and other loads as set out in 14.12.2;

.5. for a period of 30 min, any watertight doors, required by chapter 2 to be power operated, together with their indicators and warning signals;

.6. for a period of 10 min, power drives for directional control devices including those required to direct thrust forward and astern, unless there is a manual alternative acceptable to the Administration as complying with 5.2.3.

#### 12.7.5. Transitional source of emergency electrical power

The transitional source of emergency electrical power required by paragraph 12.3.6.1.3 may consist of an accumulator battery suitably located for use in an emergency which should operate without recharging while maintaining the voltage of the battery throughout the discharge period within 12% above or below its nominal voltage and be of sufficient capacity and so arranged as to supply automatically in the event of failure of either the main or emergency source of electrical power at least the following services, if they depend upon an electrical source for their operation:

.1. for a period of 30 min, the load specified in 12.7.3.1, .2 and .3, or in 12.7.4.1, .2 and .3; and

.2. with respect to the watertight doors:

.2.1. power to operate the watertight doors, but not necessarily simultaneously, unless an independent temporary source of stored energy is provided. The power source should have sufficient capacity to operate each door at least three times, i.e. closed - open - closed, against an adverse list of 15°; and

.2.2. power to the control, indication and alarm circuits for the watertight doors for half an hour.

12.7.6. The requirements of 12.7.5 may be considered satisfied without the installation of a transitional source of emergency electrical power if each of the services required by that paragraph has independent supplies, for the period specified, from accumulator batteries suitably located for use in an emergency. The supply of emergency power to the instruments and controls of the propulsion and direction systems should be uninterrupted.

12.7.7. In category A craft having limited public spaces, emergency lighting fittings of the type described in 12.7.9.1 as meeting the requirements of 12.7.3.1 and 12.7.5.1 may be accepted, provided that an adequate standard of safety is attained.

12.7.8. Provision should be made for the periodic testing of the complete emergency system including the emergency consumers required by 12.7.3 or 12.7.4 and 12.7.5, and should include the testing of automatic starting arrangements.

12.7.9. In addition to the emergency lighting required by 12.7.3.1, 12.7.4.1 and 12.7.5.1 on every craft with special category spaces:

.1. all passenger public spaces and alleyways should be provided with supplementary electric lighting that can operate for at least 3 h when all other sources of electric power have failed and under any condition of heel. The illumination provided should be such that the approach to the means of escape can be readily seen. The source of power for the supplementary lighting should consist of accumulator batteries located within the lighting units that are continuously charged, where practicable, from the emergency switchboard. Alternatively, any other means of lighting, which is at least as effective, may be accepted by the Administration.

The supplementary lighting should be such that any failure of the lamp will be immediately apparent. Any accumulator battery provided should be replaced at intervals having regard to the specified service life in the ambient condition that it is subject to in service; and

.2. a portable rechargeable battery operated lamp should be provided in every crew space alleyway, recreational space and every working space which is normally occupied unless supplementary emergency lighting, as required by .1, is provided.

12.7.10. Distribution systems should be so arranged that fire in any main vertical zone will not interfere with services essential for safety in any other such zone. This requirement will be met if main and emergency feeders passing through any such zone are separated both vertically and horizontally as widely as is practicable.

# Part C - Requirements for Cargo Craft

## 12.8 General

12.8.1. Separation and duplication of electrical supply should be provided for duplicated consumers of essential services. During normal operation these consumers may be connected to the same power-bus directly or via distribution boards or group starters, but should be separated by removable links or other approved means. Each power-bus should be able to supply all equipment necessary to maintain the control of propulsion, steering, stabilization, navigation, lighting and ventilation, and allow starting of the largest essential electric motor at any load. However, having regard to 12.1.2, partial reduction in the capability from normal operation may be accepted. Non-duplicated consumers of essential services connected to the emergency switchboard directly or via distribution boards may be accepted. Automatic load-dependent disconnection of non-essential consumers may be allowed.

### 12.8.2. Emergency source of electrical power

12.8.2.1. Where the main source of electrical power is located in two or more compartments which are not contiguous, each of which has its own self-contained systems, including power distribution and control systems, completely independent of each other and such that a fire or other casualty in any one of the spaces will not affect the power distribution from the others, or to the services required by 12.8.2.2, the requirements of 12.3.1, 12.3.2 and 12.3.4 may be considered satisfied without an additional emergency source of electrical power, provided that:

.1. there is at least one generating set, meeting the requirements of 12.3.12 and each of sufficient capacity to meet the requirements of 12.8.2.2, in each of at least two non-contiguous spaces;

.2. the arrangements required by .1 in each such space are equivalent to those required by 12.3.6.1, 12.3.7 to 12.3.11 and 12.4 so that a source of electrical power is available at all times to the services required by 12.8.2: and

.3. the generator sets referred to in .1 and their self-contained systems are installed in accordance with 12.3.2.

12.8.2.2. The electrical power available should be sufficient to supply all those services that are essential for safety in an emergency, due regard being paid to such services as may have to be operated simultaneously. The emergency source of electrical power should be capable, having regard to starting currents and the transitory nature of certain loads, of supplying simultaneously at least the following services for the periods specified hereinafter, if they depend upon an electrical source for their operation:

.1. for a period of 12 h, emergency lighting:

.1.1. at the stowage positions of life-saving appliances;

.1.2. at all escape routes such as alleyways, stairways, exits from accommodation and service spaces, embarkation points, etc.;

.1.3. in the public spaces, if any;

.1.4. in the machinery spaces and main emergency generating spaces including their control positions;

.1.5. in control stations;

.1.6. at the stowage positions for fireman's outfits; and

.1.7. at the steering gear;

.2. for a period of 12 h:

.2.1. the navigation lights and other lights required by the International Regulations for Preventing Collisions at Sea in force;

- .2.2. electrical internal communication equipment for announcements during evacuation;
- .2.3. fire detection and general alarm system and manual fire alarms; and
- .2.4. remote control devices of fire-extinguishing systems, if electrical;
- .3. for a period of 4 h of intermittent operation:
  - .3.1. the daylight signalling lamps, if they have no independent supply from their own accumulator battery; and
  - .3.2. the craft's whistle, if electrically driven;
- .4. for a period of 12 h:
  - .4.1. the navigational equipment as required by chapter 13. Where such provision is unreasonable or impracticable, the Administration may waive this requirement for craft of less than 5,000 tons gross tonnage;
  - .4.2. essential electrically powered instruments and controls for propulsion machinery, if alternate sources of power are not available for such devices;
  - .4.3. one of the fire pumps required by 7.7.8.1;
  - .4.4. the sprinkler pump and drencher pump, if fitted;
  - .4.5. the emergency bilge pump and all the equipment essential for the operation of electrically powered remote controlled bilge valves as required by chapter 10; and
  - .4.6. craft radio facilities and other loads as set out in 14.12.2;
- .5. for a period of 10 min, power drives for directional control devices including those required to direct thrust forward and astern, unless there is a manual alternative acceptable to the Administration as complying with 5.2.3.

12.8.2.3. Provision should be made for the periodic testing of the complete emergency system including the emergency consumers required by 12.8.2.2 and should include the testing of automatic starting arrangements.

12.8.2.4. Where the emergency source of electrical power is a generator, a transitional source of emergency electrical power should be provided according to 12.8.3, unless the automatic starting system and the characteristics of the prime mover are such as to permit the emergency generator to carry its full rated load as quickly as is safe and practicable, subject to a maximum of 45 s.

#### 12.8.3. Transitional source of emergency electrical power

The transitional source of emergency electrical power required by paragraph 12.8.2.4 may consist of an accumulator battery suitably located for use in an emergency which should operate without recharging while maintaining the voltage of the battery throughout the discharge period within 12% above or below its nominal voltage and be of sufficient capacity and so arranged as to supply automatically, in the event of failure of either the main or emergency source of electrical power, at least the following services, if they depend upon an electrical source for their operation:

- .1. for a period of 30 min, the load specified in 12.8.2.2.1, .2 and .3; and
- .2. with respect to the watertight doors:
  - .2.1. power to operate the watertight doors, but not necessarily simultaneously, unless an independent temporary source of stored energy is provided. The power source should have sufficient capacity to operate each door at least three times, i.e closed - open - closed against an adverse list of 15°; and
  - .2.2. power to the control, indication and alarm circuits for the watertight doors for half an hour.

# Chapter 13 - Shipborne Navigational Systems and Equipment and Voyage Data Recorder

## 13.1 General

13.1.1. This chapter covers equipment which relates to the navigation of the craft as distinct from the safe functioning of the craft. The following paragraphs represent the minimum requirements for normal safe navigation unless it is demonstrated to the Administration that an equivalent level of safety is achieved by other means.

13.1.2. The equipment and its installation should be to the satisfaction of the Administration.

13.1.3. The Administration should determine to what extent the provisions of this chapter do not apply to craft below 150 gross tonnage.

## 13.2 Compasses

13.2.1. Craft should be provided with a magnetic compass which is capable of operating without electrical supply, and which may be used for steering purposes. This compass should be mounted in a suitable binnacle containing the required correcting devices and should be suitable for the speed and motion characteristics of the craft.

13.2.2. The compass card or repeater should be capable of being easily read from the position at which the craft is normally controlled.

13.2.3. Each magnetic compass should be properly adjusted and its table or curve of residual deviations should be available at all times.

13.2.4. Care should be taken in siting a magnetic compass or magnetic sensing element so that magnetic interference is eliminated or minimized so far as practicable.

13.2.5. Passenger craft certified to carry 100 passengers or less should, in addition to the compass required by 13.2.1, be provided with an instrument, suitable for the speed and motion characteristics and area of operation of the craft, providing a heading reference of accuracy superior to that provided by a magnetic compass.

13.2.6. Cargo craft and passenger craft certified to carry more than 100 passengers should, in addition to the compass required in 13.2.1, be provided with a gyro-compass which should be suitable for the speed and motion characteristics and area of operation of the craft.

## 13.3 Speed and distance measurement

13.3.1. Craft should be provided with a device to measure speed and distance, except when no device is available which will function reliably at all speeds at which the craft may operate.

13.3.2. Speed and distance measuring devices on craft fitted with automatic radar plotting aid should be capable of measuring speed and distance through the water.

## 13.4 Echo-sounding device

13.4.1. Non-amphibious craft should be fitted with an echo-sounding device which will give an indication of depth of water to a sufficient degree of accuracy for use when the craft is in the displacement mode.

## 13.5 Radar installations

13.5.1. Craft should be provided with at least one azimuth-stabilized radar operating in the X-band (3 cm).

13.5.2. Craft of 500 tons gross tonnage and upwards or craft certified to carry more than 450 passengers should be provided with at least two radar installations. A second radar may also be provided in craft of less than 500 tons gross tonnage or certified to carry 450 passengers or less where environmental conditions so require.

13.5.3. At least one radar should be equipped with facilities for plotting which are at least as effective as a reflector plotter.

13.5.4. Adequate communication facilities should be provided between the radar observer and the person in immediate charge of the craft.

13.5.5. Each radar installation provided should be suitable for the intended craft speed, motion characteristics and commonly encountered environmental conditions.

13.5.6. Each radar installation should be mounted so as to be as free as practicable from vibration.

## **13.6 Electronic positioning systems**

. Where the area of operation of a high speed craft is covered by a reliable electronic position-fixing system, the craft should be provided with the means to fix its position using such system.

## **13.7 Rate-of-turn indicator and rudder angle indicator**

13.7.1. A rate-of-turn indicator should be provided unless the Administration determines otherwise. Means should be provided to warn the operator if an operationally dictated maximum rate of turn is being reached.

13.7.2. Craft should be provided with an indicator showing the rudder angle. In craft without a rudder, the indicator should show the direction of steering thrust.

## **13.8 Other navigational aids**

13.8.1. The information provided by navigational systems should be so displayed that the probability of misreading is reduced to a minimum and should be capable of giving readings to an optimum accuracy.

## **13.9 Searchlight**

13.9.1. Craft should be equipped with at least one adequate searchlight which should be controllable from the operating station.

13.9.2. One portable signalling lamp capable of operating independently of the craft's main electrical supply should be provided and maintained ready for use in the operating compartment at all times.

## **13.10 Night vision equipment**

13.10.1. When operational conditions justify the provision of night vision enhancement equipment, such equipment should be fitted.

## **13.11 Steering arrangement and propulsion indicators**

13.11.1. The steering arrangement should be so designed that the craft turns in the same direction as that of the wheel, tiller, joy stick or control lever.

13.11.2. Craft should be provided with indicators showing the mode of the propulsion system(s).

13.11.3. Craft with emergency steering positions should be provided with arrangements for supplying visual compass readings to the emergency steering position.

## **13.12 Automatic steering aid (automatic pilot equipment)**

13.12.1. Craft should, where possible, be equipped with automatic pilot equipment.

13.12.2. The alarm signalling facilities prescribed in paragraphs 3.1 and 3.2 of the Recommendation on performance standards for automatic pilots, adopted by the Organization by resolution A.342(IX), may be omitted.

13.12.3. Provision should be made to change from the automatic to manual mode by a manual override.

## **13.13 Voyage data recorders (VDR)**

13.13.1. To assist in casualty investigation, passenger craft should be fitted with a voyage data recorder (VDR) as follows:

- .1. ro-ro passenger craft, not later than the first survey after 1 January 2003; and
- .2. passenger craft other than ro-ro passenger craft, not later than 1 January 2004.

13.13.2. The Administration may exempt passenger craft, other than ro-ro passenger craft, from being fitted with a VDR where it can be demonstrated that interfacing a VDR with the existing equipment on the craft is unreasonable and impracticable.

13.13.3. The voyage data recorder (VDR) system, including all sensors, should be subjected to an annual performance test. The test should be conducted by an approved testing or servicing facility to verify the accuracy, duration and recoverability of the recorded data. In addition, tests and inspections should be conducted to determine the serviceability of all protective enclosure and devices fitted to aid location. A copy of a certificate of compliance issued by the testing facility stating the date of compliance and the applicable performance standards should be retained on board the craft.

## **13.14 Nautical charts and nautical publications**

13.14.1. Craft should be provided with nautical charts and nautical publications to plan and display the craft's route for the intended voyage and to plot and monitor positions throughout the voyage. An electronic chart display and information system (ECDIS) may be accepted as meeting the chart carriage requirements of this paragraph.

13.14.2. All craft, including existing craft, should be fitted with an ECDIS not later than 1 July 2010.

13.14.3. Back-up arrangements should be provided to meet the functional requirements of 13.14.1, if this function is partly or fully fulfilled by electronic means.

## **13.15 Automatic identification system (AIS)**

13.15.1. Craft should be provided with automatic identification system (AIS) as follows:

- .1. in the case of passenger craft, not later than 1 July 2003;
- .2. in the case of cargo craft of 3,000 gross tonnage and upwards, not later than 1 July 2006; and
- .3. in the case of cargo craft of less than 3,000 gross tonnage, not later than 1 July 2007.

13.15.2. AIS should:

- .1. provide automatically to appropriately equipped shore stations, other vessels and aircraft information, including the craft's identity, type, position, course, speed, navigational status and other safety-related information;
- .2. receive automatically such information from similarly fitted vessels and craft;
- .3. monitor and track vessels; and
- .4. exchange data with shore based facilities.

13.15.3. The requirements of 13.15.2 should not be applied to cases where international agreements, rules or standards provide for the protection of navigational information.

13.15.4. AIS should be operated taking into account the guidelines developed by the Organization.

## **13.16 Performance standards**

13.16.1. All equipment to which this chapter applies should be of a type approved by the Administration. Subject to 13.16.2, such equipment should conform to performance standards not inferior to those adopted by the Organization.

13.16.2. Equipment installed before the adoption of performance standards by the Organization may be exempted from full compliance with the performance standards having due regard to the criteria which the Organization may adopt in connection with such standards.

## **Chapter 14 - Radiocommunications**

. Craft should be provided with radiocommunications facilities as specified in chapter 14 of the 2000 HSC Code (resolution MSC.97(73)), as amended up to and including resolution MSC.222(82), that are fitted and operated in accordance with the provisions of that chapter.

## **Chapter 15 - Operating Compartment Layout**

### **15.1 Definitions**

15.1.1. "Operating area" is the operating compartment and those parts of the craft on both sides of, and close to, the operating compartment which extend to the craft's side.

15.1.2. "Workstation" is a position at which one or several tasks constituting a particular activity are carried out.

15.1.3. "Docking workstation" is a place equipped with necessary means for docking the craft.

15.1.4. "Primary controls" are all control equipment necessary for the safe operation of the craft when it is underway, including those required in an emergency situation.

### **15.2 General**

. The design and layout of the compartment from which the crew operate the craft should be such as to permit operating crew members to perform their duties in a correct manner without unreasonable difficulty, fatigue or concentration, and to minimize the likelihood of injury to operating crew members in both normal and emergency conditions.

### **15.3 Field of vision from the operating compartment**

15.3.1. The operating station should be placed above all other superstructures so that the operating crew are able to gain a view all round the horizon from the navigating workstation. Where it is impractical to meet the requirements of this paragraph from a single navigating workstation, the operating station should be designed so that an all-round view of the horizon is obtained using two navigating workstations combined or any other means to the satisfaction of the Administration.

15.3.2. Blind sectors should be as few and as small as possible, and not adversely affect the keeping of a safe lookout from the operating station. If stiffeners between windows are to be covered, this should not cause further obstruction inside the wheelhouse.

15.3.3. The total arc of blind sectors from right ahead to 22.5° abaft the beam on either side should not exceed 20°. Each individual blind sector should not exceed 5°. The clear sector between two blind sectors should not be less than 10°.



15.3.4. Where it is considered necessary by the Administration, the field of vision from the navigating workstation should permit the navigators from this position to utilize leading marks astern of the craft for track monitoring.

15.3.5. The view of the sea surface from the operating station, when the navigators are seated, should not be obscured by more than one craft length forward of the bow to 90° on either side irrespective of the craft's draught, trim and deck cargo.

15.3.6. The field of vision from the docking workstation, if remote from the operating station, should permit one navigator to safely manoeuvre the craft to a berth.

## 15.4 Operating compartment

15.4.1. The design and arrangement of the operating compartment, including location and layout of the individual workstations, should ensure the required field of vision for each function.

15.4.2. The craft's operating compartment should not be used for purposes other than navigation, communications and other functions essential to the safe operation of the craft, its engines, passengers and cargo.

15.4.3. The operating compartment should be provided with an integrated operating station for command, navigation, manoeuvring and communication and so arranged that it can accommodate those persons required to navigate the craft safely.

15.4.4. The arrangement of equipment and means for navigation, manoeuvring, control, communication and other essential instruments should be located sufficiently close together to enable both the officer in charge and any assisting officer to receive all necessary information and to use the equipment and controls, as required, while they are seated. If necessary, the equipment and means serving these functions should be duplicated.

15.4.5. If a separate workstation for supervision of engine performance is placed in the operating compartment, the location and use of this workstation should not interfere with the primary functions to be performed in the operating station.

15.4.6. The location of the radio equipment should not interfere with the primary navigational functions in the operating station.

15.4.7. The design and layout of the compartment from which the crew operate the craft and the relative positions of the primary controls should be assessed against the essential operational manning level. Where minimum manning levels are proposed, the design and layout of the primary and communication controls should form an integrated operational and emergency control centre from which the craft can be controlled under all operational and emergency events by the operating crew without the necessity for any crew member to vacate the compartment.

15.4.8. The relative positions of the primary controls and the seats should be such that each operating crew member, with the seat suitably adjusted, and without prejudicing compliance with 15.2 can:

.1. without interference, produce full and unrestricted movement of each control both separately and with all practical combinations of movement of other controls; and

.2. at all work stations, exert adequate control forces for the operation to be performed.

15.4.9. When a seat at a station from which the craft may be operated has been adjusted so as to suit the occupant, subsequent change of seat position to operate any control should not be acceptable.

15.4.10. In craft where the Administration considers the provision of a safety belt necessary for use by the operating crew, it should be possible for those operating crew members, with their safety belts correctly worn, to comply with 15.4.4 except in respect of controls which it can be shown will only be required on very rare occasions and which are not associated with the need for safety restraint.

15.4.11. The integrated operating station should contain equipment which provides relevant information to enable the officer in charge and any assisting officer to carry out navigational and safety functions safely and efficiently

15.4.12. Adequate arrangements should be made to prevent passengers from distracting the attention of the operating crew.

## 15.5 Instruments and chart table

15.5.1. Instruments, instrument panels and controls should be permanently mounted in consoles or other appropriate places taking into account operation, maintenance and environmental conditions. However, this should not prevent the use of new control or display techniques, provided the facilities offered are not inferior to recognized standards.

15.5.2. All instruments should be logically grouped according to their functions. In order to reduce to a minimum the risk of confusion, instruments should not be rationalized by sharing functions or by interswitching.

15.5.3. Instruments required for use by any member of the operating crew should be plainly visible and easily read:

- .1. with minimum practicable deviation from his normal seating position and line of vision; and
- .2. with the minimum risk of confusion under all likely operating conditions.

15.5.4. Instruments essential for the safe operation of the craft should be clearly marked with any limitation if this information is not otherwise clearly presented to the operating crew. The instrument panels forming the emergency control for the launching of liferafts and the monitoring of the fire-fighting systems should be in separate and clearly defined positions within the operating area.

15.5.5. The instruments and controls should be provided with means for screening and dimming in order to minimize glare and reflections and prevent them being obscured by strong light.

15.5.6. The surfaces of console tops and instruments should have dark glare-free colours.

15.5.7. Instruments and displays, providing visual information to more than one person, should be located for easy viewing by all users concurrently. If this is not possible, the instrument or display should be duplicated.

15.5.8. If considered necessary by the Administration, the operating compartment should be provided with a suitable table for chart work. There should be facilities for lighting the chart. Chart table lighting should be screened.

## 15.6 Lighting

15.6.1. A satisfactory level of lighting should be available to enable the operating personnel to adequately perform all their tasks both at sea and in port, by day and night. There should be only a limited reduction in the illumination of essential instruments and controls under likely system fault conditions.

15.6.2. Care should be taken to avoid glare and stray image reflection in the operating area environment. High contrast in brightness between work area and surroundings should be avoided. Non-reflective or matt surfaces should be used to reduce indirect glare to a minimum.

15.6.3. A satisfactory degree of flexibility within the lighting system should be available to enable the operating personnel to adjust the lighting intensity and direction as required in the different areas of the operating compartment and at individual instruments and controls.

15.6.4. Red light should be used to maintain dark adaptation whenever possible in areas or on items of equipment requiring illumination in the operational mode, other than chart table.

15.6.5. During hours of darkness, it should be possible to discern displayed information and control devices.

15.6.6. Reference is made to additional requirements on lighting in 12.7 and 12.8.

## **15.7 Windows**

15.7.1. Divisions between windows, located in the front, on the sides and in the doors, should be kept to a minimum. No division should be installed immediately forward of the operating stations.

15.7.2. Administrations should be satisfied that a clear view through the operating compartment windows is provided at all times regardless of weather conditions. The means provided for maintaining the windows in a clear condition should be so arranged that no reasonably probable single failure can result in a reduction of the cleared field of vision such as to interfere seriously with the ability of the operating crew to continue the operation and bring the craft to rest.

15.7.3. Arrangements should be provided so that the forward view from operating stations is not adversely affected by solar glare. Neither polarized nor tinted window glass should be fitted.

15.7.4. Operating compartment windows should be angled to reduce unwanted reflection.

15.7.5. The windows should be made of material which will not break into dangerous fragments if fractured.

## **15.8 Communication facilities**

15.8.1. Such means as are necessary should be provided to enable the crew to communicate between, and have access to, each other and with other occupants of the craft in both normal and emergency conditions.

15.8.2. Means to communicate between the operating compartment and spaces containing essential machinery, including any emergency steering position, irrespective of whether the machinery is remotely or locally controlled, should be provided.

15.8.3. Means for making public address and safety announcements from control stations to all areas to which passengers and crew have access should be provided.

15.8.4. Provisions should be made for means to monitor, receive and transmit radio safety messages at the operating compartment.

## **15.9 Temperature and ventilation**

. The operating compartment should be equipped with adequate temperature and ventilation control systems.

## **15.10 Colours**

. The surface materials inside the operating compartment should have a suitable colour and finish to avoid reflections.

## **15.11 Safety measures**

. The operating area should be free of physical hazard to the operating personnel and have non-skid flooring in dry and wet conditions and adequate handrails. Doors should be fitted with devices to prevent them moving, whether they are open or closed.

# **Chapter 16 - Stabilization Systems**

## **16.1 Definitions**

16.1.1. "Stabilization control system" is a system intended to stabilize the main parameters of the craft's attitude: heel, trim, course and height and control the craft's motions: roll, pitch, yaw and heave. This term excludes devices not associated with the safe operation of the craft, e.g. motion reduction or ride control systems.

The main elements of a stabilization control system may include the following:

.1. devices such as rudders, foils, flaps, skirts, fans, water jets, tilting and steerable propellers, pumps for moving fluids;

.2. power drives actuating stabilization devices; and

.3. stabilization equipment for accumulating and processing data for making decisions and giving commands such as sensors, logic processors and automatic safety control.

16.1.2. "Self-stabilization" of the craft is stabilization ensured solely by the craft's inherent characteristics.

16.1.3. "Forced stabilization" of the craft is stabilization achieved by:

.1. an automatic control system; or

.2. a manually control assisted system; or

.3. a combined system incorporating elements of both automatic and manually assisted control systems.

16.1.4. "Augmented stabilization" is a combination of self-stabilization and forced stabilization.

16.1.5. "Stabilization device" means a device as enumerated in 16.1.1.1 with the aid of which forces for controlling the craft's position are generated.

16.1.6. "Automatic safety control" is a logic unit for processing data and making decisions to put the craft into the displacement or other safe mode if a condition impairing safety arises.

## 16.2 General requirements

16.2.1. Stabilization systems should be so designed that in case of failure or malfunctioning of any one of the stabilization devices, or equipment, it would be possible either to ensure maintaining the main parameters of craft's motion within safe limits with the aid of working stabilization devices or to put the craft into the displacement or other safe mode.

16.2.2. In case of failure of any automatic equipment or stabilization device, or its power drive, the parameters of craft motion should remain within safe limits.

16.2.3. Craft fitted with an automatic stabilization system should be provided with an automatic safety control unless the redundancy in the system provides equivalent safety. Where an automatic safety control is fitted, provision should be made to override it and to cancel the override from the main operating station.

16.2.4. The parameters and the levels at which any automatic safety control gives the command to decrease speed and put the craft safely in the displacement or other safe mode should take account of the safe values of heel, trim, yaw and combination of trim and draught appropriate to the particular craft and service; also to the possible consequences of power failure for propulsion, lift or stabilization devices.

16.2.5. The parameters and the degree of stabilization of the craft provided by the automatic stabilization system should be satisfactory having regard to the purpose and service conditions of the craft.

16.2.6. Failure mode and effect analysis should include the stabilization system.

## 16.3 Lateral and height control systems

16.3.1. Craft fitted with an automatic control system should be provided with an automatic safety control. Probable malfunctions should have only minor effects on automatic control system operation and should be capable of being readily counteracted by the operating crew.

16.3.2. The parameters and levels at which any automatic control system gives the command to decrease speed and put the craft safely into the displacement or other safe mode should take account of the safety levels as given in section 2.4 of annex 3 and of the safe values of motions appropriate to the particular craft and service.

## 16.4 Demonstrations

16.4.1. The limits of safe use of any of the stabilization control system devices should be based on demonstrations and verification process in accordance with annex 8.

16.4.2. Demonstration in accordance with annex 8 should determine any adverse effects upon safe operation of the craft in the event of an uncontrollable total deflection of any one control device. Any limitation on the operation of the craft as may be necessary to ensure that the redundancy or safeguards in the systems provide equivalent safety should be included in the craft operating manual.

## 16.4 Demonstrations

16.4.1. The limits of safe use of any of the stabilization control system devices should be based on demonstrations and verification process in accordance with annex 8.

16.4.2. Demonstration in accordance with annex 8 should determine any adverse effects upon safe operation of the craft in the event of an uncontrollable total deflection of any one control device. Any limitation on the operation of the craft as may be necessary to ensure that the redundancy or safeguards in the systems provide equivalent safety should be included in the craft operating manual.

## 17.1 General

. The operational safety of the craft in normal service conditions and in equipment failure situations of a craft to which this Code applies should be demonstrated by full-scale tests of the prototype craft. The objective of tests is to determine information to be included in the craft operating manual in relation to:

- .1. handling and performance limitations;
- .2. actions to be taken in the event of prescribed failure; and
- .3. limitations to be observed for safe operation subsequent to prescribed failures.

## 17.2 Proof of compliance

. The information on controllability and manoeuvrability which should be contained in the operating manual should include the characteristics under 17.5, and the list of parameters of the worst intended conditions affecting the controllability and manoeuvrability according to 17.6 and the performance data verified in accordance with annex 8.

## 17.3 Weight and centre of gravity

. Compliance with each of the handling, controllability and performance requirements should be established for all combinations of weight and centre of gravity position significant for the operational safety in the range of weights up to the maximum permissible weight.

## 17.4 Effect of failures

. The effect of any likely failure in handling and control devices, services or components (e.g. power operation, power assistance, trimming and stability augmentation) should be assessed in order that a safe level of craft operation can be maintained. Effects of failure identified as being critical according to annex 4 should be verified in accordance with annex 8.

## 17.5 Controllability and manoeuvrability

17.5.1. Instructions to crew members should be provided in the craft operating manual regarding required actions and craft limitations subsequent to prescribed failures.

17.5.2. It is necessary to ensure that the effort required to operate the controls in the worst intended conditions is not such that the person at the control will be unduly fatigued or distracted by the effort necessary to maintain the safe operation of the craft.

17.5.3. The craft should be controllable and be capable of performing those manoeuvres essential to its safe operation up to the critical design conditions.

17.5.4.1. When determining the safety of a craft in respect of handling, controllability and performance, the Administration should pay particular attention to the following aspects during normal operation and during and subsequent to failures:

- .1. yawing;
- .2. turning;
- .3. stopping in normal and emergency conditions;
- .4. stability in the non-displacement mode about three axes and in heave;
- .5. trim;
- .6. plough in; and
- .7. lift power limitations.

17.5.4.2. The terms in 17.5.4.1.2, .6 and .7 are defined as follows:

- .1. "Turning" is the rate of change of direction of a craft at its normal maximum operating speed in specified wind and sea conditions.
- .2. "Plough in" is an involuntary motion involving sustained increase in drag of an air-cushion vehicle at speed, usually associated with partial collapse of the cushion system.
- .3. "Lift power limitations" are those limitations imposed upon the machinery and components which provide the lift.

## **17.6 Change of operating surface and mode**

. There should be no unsafe change in the stability, controllability or attitude of the craft during transition from one type of operating surface or mode to another. Information on change in the behaviour characteristics of the craft during transition should be available to the master.

## **17.7 Surface irregularities**

. Factors which limit the ability of the craft to operate over sloping ground and steps or discontinuities should be determined, as applicable, and made available to the master.

## **17.8 Acceleration and deceleration**

. The Administration should be satisfied that the worst likely acceleration or deceleration of the craft, due to any likely failure, emergency stopping procedures or other likely causes, would not hazard the persons on the craft.

## **17.9 Speeds**

. Safe maximum speeds should be determined, taking account of modes of operation, wind force and direction and the effects of possible failures of any one lift or propulsion system over calm water, rough water and over other surfaces as appropriate to the craft.

## **17.10 Minimum depth of water**

. The minimum depth of water and other appropriate information required for operations in all modes should be determined.

## 17.11 Hard structure clearance

. For amphibious craft, when cushion borne, clearance of the lowest point of the hard structure above a hard flat surface should be determined.

## 17.12 Night operation

. The schedule of tests should include sufficient operation to evaluate the adequacy of internal and external lighting and visibility, under conditions of normal and emergency electrical power supply during service, cruising and docking manoeuvres.

# Chapter 18 - Operational Requirements

## Part A – General

### 18.1 Craft operational control

18.1.1. The High Speed Craft Safety Certificate, the Permit to Operate High Speed Craft or certified copies thereof, and copies of the route operational manual, craft operating manual, and a copy of such elements of the maintenance manual as the Administration may require, should be carried on board.

18.1.2. The craft should not be intentionally operated outside the worst intended conditions and limitations specified in the Permit to Operate High Speed Craft, in the High Speed Craft Safety Certificate, or in documents referred to therein.

18.1.3. The Administration should issue a Permit to Operate High Speed Craft when it is satisfied that the operator has made adequate provisions from the point of view of safety generally, including the following matters specifically, and should revoke the Permit to Operate if such provisions are not maintained to its satisfaction:

- .1. the suitability of the craft for the service intended having regard to the safety limitations and information contained in the route operational manual;
- .2. the suitability of the operating conditions in the route operational manual;
- .3. the arrangements for obtaining weather information on the basis of which the commencement of a voyage may be authorized;
- .4. provision in the area of operation of a base port fitted with facilities in accordance with 18.1.4;
- .5. the designation of the person responsible for decisions to cancel or delay a particular voyage, e.g. in the light of the weather information available;
- .6. sufficient crew complement required for operating the craft, deploying and manning survival craft, the supervision of passengers, vehicles and cargo in both normal and emergency conditions as defined in the Permit to Operate. The crew complement should be such that two officers are on duty in the operating compartment when the craft is underway, one of whom may be the master;
- .7. crew qualifications and training, including competence in relation to the particular type of craft and service intended, and their instructions in regard to safe operational procedures;
- .8. restrictions with regard to working hours, rostering of crews and any other arrangements to prevent fatigue including adequate rest periods;
- .9. the training of crew in craft operation and emergency procedures;
- .10. the maintenance of crew competence in regard to operation and emergency procedures;
- .11. safety arrangements at terminals and compliance with any existing safety arrangements, as appropriate;

- .12. traffic control arrangements and compliance with any existing traffic control, as appropriate;
- .13. restrictions and/or provisions relating to position fixing, to operation by night or in restricted visibility, including the use of radar and/or other electronic aids to navigation, as appropriate;
- .14. additional equipment which may be required, due to the specific characteristics of the service intended, for example, night operation;
- .15. communication arrangements between craft, coast radio stations, base ports radio stations, emergency services and other ships, including radio frequencies to be used and watch to be kept;
- .16. the keeping of records to enable the Administration to verify:
  - .16.1. that the craft is operated within the specified parameters;
  - .16.2. the observance of emergency and safety drills/procedures;
  - .16.3. the hours worked by the operating crew;
  - .16.4. the number of passengers on board;
  - .16.5. compliance with any law to which the craft is subject;
  - .16.6. craft operations; and
  - .16.7. maintenance of the craft and its machinery in accordance with approved schedules;
- .17. arrangements to ensure that equipment is maintained in compliance with the Administration's requirements, and to ensure co-ordination of information as to the serviceability of the craft and equipment between the operating and maintenance elements of the operator's organization;
- .18. the existence and use of adequate instructions regarding:
  - .18.1. loading of the craft so that weight and centre of gravity limitations can be effectively observed and cargo is, when necessary, adequately secured;
  - .18.2. the provision of adequate fuel reserves;
  - .18.3. action in the event of reasonable foreseeable emergencies; and
  - .19. provision of contingency plans by operators for foreseeable incidents including all land-based activities for each scenario. The plans should provide operating crews with information regarding search and rescue (SAR) authorities and local administrations and organizations which may complement the tasks undertaken by crews with the equipment available to them .
    - 18.1.4. The Administration should determine the maximum allowable distance from a base port or place of refuge after assessing the provisions made under 18.1.3.

## **18.2 Craft documentation**

. The Administration should ensure that the craft is provided with adequate information and guidance in the form of technical manual(s) to enable the craft to be operated and maintained safely. The technical manual(s) should consist of a Route Operational Manual, Craft Operating Manual, Training Manual, Maintenance Manual and Servicing Schedule. Arrangements should be made for such information to be updated as necessary.

### **18.2.1 Craft operating manual**

. The craft operating manual should contain at least the following information:



- .1. leading particulars of the craft;
- .2. description of the craft and its equipment;
- .3. procedures for checking the integrity of buoyancy compartments;
- .4. details arising from compliance with the requirements of chapter 2 likely to be of direct practical use to the crew in an emergency;
- .5. damage control procedures;
- .6. description and operation of machinery systems;
- .7. description and operation of auxiliary systems;
- .8. description and operation of remote control and warning systems;
- .9. description and operation of electrical equipment;
- .10. loading procedures and limitations including maximum operational weight, centre of gravity position and distribution of load;
- .11. description and operation of fire detection and fire-extinguishing equipment;
- .12. drawings indicating the structural fire protection arrangements;
- .13. description and operation of radio equipment and navigational aids;
- .14. information regarding the handling of the craft as determined in accordance with chapter 17;
- .15. maximum permissible towing speeds and towing loads, where applicable;
- .16. procedure for dry-docking or lifting, including limitations;
- .17. in particular, the manual should provide information, in clearly defined chapters approved specifically by the Administration, relating to:
  - .17.1. indication of emergency situations or malfunctions jeopardizing safety, required actions to be taken and any consequential restrictions on operation of the craft or its machinery;
  - .17.2. evacuation procedures;
  - .17.3. operating limitations including the worst intended conditions;
  - .17.4. limiting values of all machinery parameters requiring compliance for safe operation.

In regard to information on machinery or system failures, data should take into account the results of any FMEA reports developed during the craft design.

## **18.2.2 Route operational manual**

. The route operational manual should include at least the following information:

- .1. evacuation procedures;
- .2. operating limitations including the worst intended conditions such as sea height, sea and air temperatures, and wind conditions;

- .3. procedures for operation of the craft within the limitations of .2;
- .4. the elements of applicable contingency plans for primary and secondary rescue assistance in the case of foreseeable incidents, including land-based arrangements and activities for each incident;
- .5. arrangements for obtaining weather information;
- .6. identification of the "base port(s)";
- .7. identification of the person responsible for decisions to cancel or delay voyages;
- .8. identification of crew complement, functions and qualifications;
- .9. restrictions on working hours of crew;
- .10. safety arrangements at terminals;
- .11. traffic control arrangements and limitations, as appropriate;
- .12. specific route conditions or requirements relating to position fixing, operations by night and in restricted visibility, including the use of radar or other electronic aids to navigation; and
- .13. communication arrangements between craft, coast radio stations, base ports radio stations, emergency services and other ships, including radio frequencies to be used and watch to be kept.

### **18.2.3 Training manual**

. The training manual, which may comprise several volumes, should contain instructions and information, in easily understood terms illustrated wherever possible, on evacuation, fire and damage control appliances and systems and on the best methods of survival. Any part of such information may be provided in the form of audio-visual aids in lieu of the manual. Where appropriate the contents of the training manual may be included in the craft operating manual. The following should be explained in detail:

- .1. donning lifejackets and immersion suits, as appropriate;
- .2. muster at the assigned stations;
- .3. boarding, launching and clearing the survival craft and rescue boats;
- .4. method of launching from within the survival craft;
- .5. release from launching appliances;
- .6. methods and use of devices for protection in launching areas, where appropriate;
- .7. illumination in launching areas;
- .8. use of all survival equipment;
- .9. use of all detection equipment;
- .10. with the assistance of illustrations, the use of radio life-saving appliances;
- .11. use of drogues;
- .12. use of engine and accessories;
- .13. recovery of survival craft and rescue boats including stowage and securing;

- .14. hazards of exposure and the need for warm clothing;
- .15. best use of the survival craft facilities in order to survive;
- .16. methods of retrieval, including the use of helicopter rescue gear (slings, baskets, stretchers), breeches-buoy and shore life-saving apparatus and craft's line-throwing apparatus;
- .17. all other functions contained in the muster list and emergency instructions; and
- .18. instructions for emergency repair of the life-saving appliances.
- .19. instructions in the use of fire protection and fire-extinguishing appliances and systems;
- .20. guidelines for use of fireman's outfit in a fire, if fitted;
- .21. use of alarms and communications associated with fire safety;
- .22. methods for surveying damage;
- .23. use of damage control appliances and systems including operation of watertight doors and bilge pumps; and
- .24. for passenger craft, control of and communication with passengers in an emergency.

#### **18.2.4 Maintenance and servicing manual**

. The craft maintenance and servicing manual should contain as a minimum:

- .1. detailed, illustrated description of all craft structure, machinery installations and all installed equipment and systems required for safe operation of the craft;
- .2. specifications and quantities of all replenishable fluids, and of structural materials which may be required for repairs;
- .3. operational limitations of machinery in terms of values of parameters, vibration and consumption of replenished fluids;
- .4. limitations of wear of structure or machinery components, including lives of components requiring calendar or operating time replacement;
- .5. detailed description of procedures, including any safety precautions to be taken or special equipment required, to remove and install main and auxiliary machinery, transmissions, propulsion and lift devices and flexible structure components;
- .6. test procedures to be followed subsequent to replacement of machinery or system components or for malfunction diagnosis;
- .7. procedure for lifting or dry-docking the craft, including any weight or attitude limitations;
- .8. procedure for weighing the craft and establishing the position of longitudinal centre of gravity (LCG);
- .9. where craft may be dismantled for transportation, instructions should be provided for dismantling, transport and re-assembly;
- .10. a servicing schedule, included in the maintenance manual or published separately, detailing the routine servicing and maintenance operations required to maintain the operational safety of the craft and its machinery and systems.

## 18.3 Training and qualifications

18.3.1. The level of competence and the training considered necessary in respect of the master and each crew member should be laid down and demonstrated in the light of the following guidelines to the satisfaction of the Administration in respect of the particular type and model of craft concerned and the service intended. More than one crew member should be trained to perform all essential operational tasks in both normal and emergency situations.

18.3.2. The Administration should specify an appropriate period of operational training for the master and each member of the crew and, if necessary, the periods at which appropriate re-training should be carried out.

18.3.3. The Administration should issue a type rating certificate to the master and all officers having an operational role following an appropriate period of operational/simulator training and on the conclusion of an examination including practical test commensurate with the operational tasks on board the particular type and model of craft concerned and the route followed. The type rating training should cover at least the following items:

- .1. knowledge of all on-board propulsion and control systems, including communication and navigational equipment, steering, electrical, hydraulic and pneumatic systems and bilge and fire pumping;
- .2. the failure mode of the control, steering and propulsion systems and proper response to such failures;
- .3. handling characteristics of the craft and the limiting operational conditions;
- .4. bridge communication and navigation procedures;
- .5. intact and damage stability and survivability of the craft in damage condition;
- .6. location and use of the craft's life-saving appliances, including survival craft equipment;
- .7. location and use of escapes in the craft and the evacuation of passengers;
- .8. location and use of fire protection and fire-extinguishing appliances and systems in the event of fire on board;
- .9. location and use of damage control appliances and systems including operation of watertight doors and bilge pumps;
- .10. cargo and vehicle stowage securement systems;
- .11. methods for control of and communication with passengers in an emergency; and
- .12. location and use of all other items listed in the training manual.

18.3.4. The type rating certificate for a particular type and model of craft should only be valid for service on the route to be followed when it is so endorsed by the Administration following the completion of a practical test over that route.

18.3.5. The type rating certificate should be re-validated every two years and the Administration should lay down the procedures for re-validation.

18.3.6. All crew members should receive instructions and training, as specified in 18.3.3.6 to 12.

18.3.7. The Administration should specify standards of physical fitness and frequency of medical examinations having regard to the route and craft concerned.

18.3.8. The Administration of the country in which the craft is to operate, if other than the flag State, should be satisfied with the training, experience and qualifications of the master and each crew member. A valid type rating certificate appropriately endorsed and held by a master or crew member, in conjunction with the current and valid licence or certificate issued by a flag State which is signatory to the International Convention on Standards of Training, Certification and Watchkeeping (STCW) in force for those who are required to hold such a licence or

certificate, should be acceptable as evidence of satisfactory training, experience and qualification to the Administration of the country in which the craft is to operate.

## **18.4 Manning of survival craft and supervision**

*18.4.1.* There should be a sufficient number of trained persons on board for mustering and assisting untrained persons.

*18.4.2.* There should be a sufficient number of crew members, who may be deck officers or certificated persons, on board for operating the survival craft, rescue boats and launching arrangements required for abandonment by the total number of persons on board.

*18.4.3.* A deck officer or certificated person should be placed in charge of each survival craft to be used. However, the Administration, having due regard to the nature of the voyage, the number of persons on board and the characteristics of the craft, may permit a deck officer, certificated person or persons practised in the handling and operation of liferafts to be placed in charge of each liferaft or group of liferafts.

*18.4.4.* The person in charge of survival craft should have a list of the survival craft crew and should see that the crew under command are acquainted with their duties.

*18.4.5.* Every rescue boat and motorized survival craft should have a person assigned who is capable of operating the engine and carrying out minor adjustments.

*18.4.6.* The master should ensure the equitable distribution of persons referred to in 18.4.1 to 18.4.3 among the craft's survival craft.

## **18.5 Emergency instructions and drills**

*18.5.1.* On or before departure, passengers should be instructed in the use of lifejackets and the action to be taken in an emergency. The attention of the passengers should be drawn to the emergency instructions required by 8.4.1 and 8.4.3.

*18.5.2.* Emergency fire and evacuation drills for the crew should be held on board the craft at intervals not exceeding one week for passenger craft and one month for cargo craft.

*18.5.3.* Each member of each crew should participate in at least one evacuation, fire and damage control drill per month.

*18.5.4.* On-board drills should, as far as practicable, be conducted to simulate an actual emergency. Such simulations should include instruction and operation of the craft's evacuation, fire and damage control appliances and systems.

*18.5.5.* On-board instruction and operation of the craft's evacuation, fire and damage control appliances and systems should include appropriate cross-training of crew members.

*18.5.6.* Emergency instructions including a general diagram of the craft showing the location of all exits, routes of evacuation, emergency equipment, life-saving equipment and appliances and illustration of lifejacket donning should be available to each passenger and crew member. It should be placed near each passenger and crew seat.

*18.5.7.* Records

The date when musters are held, details of abandon craft drills and fire drills, drills of other life-saving appliances and on-board training should be recorded in such log-book as may be prescribed by the Administration. If a full muster, drill or training session is not held at the appointed time, an entry should be made in the log-book stating the circumstances and the extent of the muster, drill or training session held. A copy of such information should be forwarded to the operator's management.

*18.5.8.* Evacuation drills

*18.5.8.1.* Evacuation drill scenarios should vary each week so that different emergency conditions are simulated.

18.5.8.2. Each evacuation craft drill should include:

- .1. summoning of crew to muster stations with the alarm required by 8.2.2.2 and ensuring that they are made aware of the order to abandon craft specified in the muster list;
- .2. reporting to stations and preparing for the duties described in the muster list;
- .3. checking that crew are suitably dressed;
- .4. checking that lifejackets are correctly donned;
- .5. operation of davits if any used for launching liferafts;
- .6. donning of immersion suits or thermal protective clothing by appropriate crew members;
- .7. testing of emergency lighting for mustering and abandonment; and
- .8. giving instructions in the use of the craft's life-saving appliances and in survival at sea.

18.5.8.3. Rescue boat drill

- .1. As far as is reasonable and practicable, rescue boats should be launched each month as part of the evacuation drill, with their assigned crew aboard, and manoeuvred in the water. In all cases this requirement should be complied with at least once every three months.
- .2. If rescue boat launching drills are carried out with the craft making headway, such drills should, because of the dangers involved, be practised in sheltered waters only and under the supervision of an officer experienced in such drills.

18.5.8.4. Individual instructions may cover different parts of the craft's life-saving system, but all the craft's life-saving equipment and appliances should be covered within any period of one month on passenger craft and two months on cargo craft. Each member of the crew should be given instructions which should include but not necessarily be limited to:

- .1. operation and use of the craft's inflatable liferafts;
- .2. problems of hypothermia, first-aid treatment of hypothermia and other appropriate first-aid procedures;
- .3. special instructions necessary for use of the craft's life-saving appliances in severe weather and severe sea conditions.

18.5.8.5. On-board training in the use of davit-launched liferafts should take place at intervals of not more than four months on every craft fitted with such appliances. Whenever practicable, this should include the inflation and lowering of a liferaft. This liferaft may be a special liferaft intended for training purposes only, which is not part of the craft's life-saving equipment. Such a special liferaft should be conspicuously marked.

18.5.9. Fire drills

18.5.9.1. Fire drill scenarios should vary each week so that emergency conditions are simulated for different vessel compartments;

18.5.9.2. Each fire drill should include:

- .1. summoning of crew to fire stations;
- .2. reporting to stations and preparing for the duties described in the muster list;
- .3. donning of fireman's outfits;

- .4. operation of fire doors and fire dampers;
- .5. operation of fire pumps and fire-fighting equipment;
- .6. operation of communication equipment, emergency signals and general alarm;
- .7. operation of fire detection system; and
- .8. instruction in the use of the craft's fire-fighting equipment and sprinkler and drencher systems, if fitted.

#### 18.5.10. Damage control drills

18.5.10.1. Damage control drill scenarios should vary each week so that emergency conditions are simulated for different damage conditions.

18.5.10.2. Each damage control drill should include:

- .1. summoning of crew to damage control stations;
- .2. reporting to stations and preparing for the duties described in the muster list;
- .3. operation of watertight doors and other watertight closures;
- .4. operation of bilge pumps and testing of bilge alarms and automatic bilge pump starting systems; and
- .5. instruction in damage survey, use of the craft damage control systems and passenger control in the event of an emergency.

## Part B- Requirements for Passenger Craft

### 18.6 Type rating training

18.6.1. For all crew members, the type rating training should cover the control and evacuation of passengers additionally to 18.3.6.

18.6.2. When the craft carry cargoes, the craft should comply with the requirements of part C of this chapter in addition to this part.

### 18.7 Emergency instructions and drills

18.7.1. Emergency instructions including a general diagram of the craft showing the location of all exits, routes of evacuation, emergency equipment, life-saving equipment and appliances and illustration of lifejacket donning should be available to each passenger and placed near each passenger's seat.

18.7.2. Attention of passengers should be drawn to the provisions of the emergency instructions on boarding.

## Part C - Requirements for Cargo Craft

### 18.8 Type rating training

. For all crew members, the type rating training should cover knowledge of cargo and vehicles storage area securement systems.

### 18.9 Emergency instructions and drills

. Emergency instructions including a general diagram of the craft showing the location of all exits, routes of evacuation, emergency equipment, life-saving equipment and appliances and illustration of lifejacket donning should be available to each crew member

## Chapter 19 - Inspection and Maintenance Requirements

19.1. The Administration should be satisfied with the operator's organization or any organization on which he may call in the maintenance of his craft and should specify the scope of the duties which any part of the organization may carry out having regard to the number and competence of its staff, facilities available, arrangements for calling on specialist assistance should it be necessary, record-keeping, communication and allocation of responsibilities.

19.2. The craft and equipment should be maintained to the satisfaction of the Administration, in particular:

.1. routine preventive inspection and maintenance should be performed to a schedule approved by the Administration, which should have regard at least in the first instance to the manufacturer's schedule;

.2. in the performance of maintenance tasks, due regard should be paid to maintenance manuals, service bulletins acceptable to the Administration and to any additional instructions of the Administration in this respect;

.3. all modifications should be recorded and their safety aspects investigated. Where it could have any effect on safety, the modification, together with its installation, should be to the satisfaction of the Administration;

.4. appropriate arrangements should be provided for informing the master of the serviceability state of his craft and its equipment;

.5. the duties of the operating crew in respect of maintenance and repairs and the procedure for obtaining assistance with repairs when the craft is away from the base port should be clearly defined;

.6. the master should report to the maintenance organization any defects and repairs which are known to have occurred during operations;

.7. records of defects and their correction should be maintained and those defects of recurrent nature, or those which adversely affect craft or personal safety, should be reported to the Administration.

19.3. The Administration should be satisfied that arrangements are provided for ensuring adequate inspection, maintenance and recording of all life-saving appliances and distress signals carried.



# Annex 1 - Form of Safety Certificate for High Speed Craft

## 1.1.1 Form of Safety Certificate for High Speed Craft

HIGH SPEED CRAFT SAFETY CERTIFICATE	
This Certificate should be supplemented by a Record of Equipment	
(Official seal)	(State)
Issued under the provisions of the	
INTERNATIONAL CODE OF SAFETY FOR HIGH SPEED CRAFT	
(Resolution MSC.36(63))	
under the authority of the Government of	
.....	
(full designation of the state)	
by.....	
(full official designation of the competent person or organisation authorised by the Administration)	
Particulars of craft	
Name of craft .....	
Manufacturer's model and hull number .....	
Distinctive number or letters.....	
IMO number .....	
Port of Registry .....	
Gross Tonnage .....	
Design waterline corresponding to draughts at draught marks of...forward/...aft	
Category	category A passenger craft/category B passenger craft/cargo
Craft Type	air-cushion vehicle/surface effect ship/hydrofoil/ monohull/ multihull/other (give detail .....)
Date on which keel was laid or craft was at a similar stage of construction or on which a major conversion was commenced .....	
THIS IS TO CERTIFY :	
1 That the above-mentioned craft has been duly surveyed in accordance with the applicable provisions of the International Code of Safety for High Speed Craft.	
2 That the survey showed that the structure, equipment, fittings, radio station arrangements and materials of the craft and the condition thereof are in all respects satisfactory and that the craft complies with the relevant provisions of the Code.	
3 That the life-saving appliances are provided for a total number of persons and no more as follows	
.....	

4 That, in accordance with 1.11 of the code , the following equivalentents have been granted in respect of the craft:

paragraph ..... equivalent arrangement .....  
.....

This certificate is valid until.....

Completion date of the survey on which this certificate is based: .....

(dd/mm/yyyy)

Issued at .....

(Place of issue of certificate)

.....

.....

(Date of issue)

(Signature of authorised official issuing the certificate)

.....

(Seal or stamp of the issuing authority, as appropriate)

Endorsement for periodical surveys

This is to certify that, at a survey required by 1.5 of the code, this craft, was found to comply with the relevant provisions of the Code.

Periodical survey: Signed: .....

.....

(Signature of authorized official)

Place: .....

Date: .....

.....

(Seal or stamp of authority, as appropriate)

Periodical survey: Signed: .....

.....

(Signature of authorized official)

Place: .....

Date: .....

.....

(Seal or stamp of authority, as appropriate)

Periodical survey: Signed: .....

.....

(Signature of authorized official)

Place: .....

Date: .....

.....

*(Seal or stamp of authority, as appropriate)*

Periodical survey:

Signed: .....

.....

*(Signature of authorized official)*

Place: .....

Date: .....

.....

*(Seal or stamp of authority, as appropriate)*

**Endorsement to extend the Certificate if valid for less than 5 years where 1.8.8 of the code applies**

This craft complies with the relevant requirements of the Code, and this Certificate should, in accordance with 1.8.8 of the Code, be accepted as valid until .....

Signed: .....

*(Signature of authorized official)*

Place: .....

Date: .....

.....

*(Seal or stamp of authority, as appropriate)*

**Endorsement where the renewal survey has been completed and 1.8.9 of the code applies**

This craft complies with the relevant requirements of the code and this Certificate should, in accordance with 1.8.9 of the Code be accepted as valid until .....

Signed: .....

*(Signature of authorized official)*

Place: .....

Date: .....

.....

*(Seal or stamp of authority, as appropriate)*

**Endorsement to extend the validity of the Certificate until reaching the port of survey where 1.8.10 of the code applies**

This Certificate should, in accordance with 1.8.10 of the code, be accepted as valid until .....

Signed: .....

*(Signature of authorized official)*

Place: .....

Date: .....

.....

*(Seal or stamp of authority, as appropriate)*

**Endorsement for the advancement of the anniversary date where 1.8.13 of the code applies**

In accordance with 1.8.13 of the code, the new anniversary date is .....

Signed: .....

*(Signature of authorized official)*

Place: .....

Date: .....

.....

*(Seal or stamp of authority, as appropriate)*

In accordance with 1.8.13 of the code, the new anniversary date is .....

Signed: .....

*(Signature of authorized official)*

Place: .....

Date: .....

.....

*(Seal or stamp of authority, as appropriate)*

**1.1.7 RECORD OF EQUIPMENT FOR HIGH SPEED CRAFT SAFETY CERTIFICATE**

This Record shall be permanently attached to the High Speed Craft Safety Certificate

**RECORD OF EQUIPMENT FOR COMPLIANCE WITH THE INTERNATIONAL CODE OF SAFETY FOR HIGH SPEED CRAFT**

1 *Particulars of craft*

Name of craft .....

Manufacturer's model and hull number .....

IMO Number .....

Category: Category A passenger craft/category B passenger craft/cargo craft

Craft type: air cushion, surface effect ship, hydrofoil, monohull, multihull, other (give details .....)

Number of passengers for which certified .....

Minimum number of persons with required qualifications to operate this radio installations .....		
2	<i>Details of life-saving appliances</i>	.....
1	Total number of persons for which life-saving appliances are provided	.....
2	Total number of lifeboats	.....
2.1	Total number of persons accommodated by them	.....
2.2	Number of partially enclosed lifeboats complying with SOLAS regulation III/42	.....
2.3	Number of totally enclosed lifeboats complying with SOLAS regulation III/44	.....
2.4	Other lifeboat	.....
2.4.1	Number	.....
2.4.2	Type	.....
3	Number of rescue boats	.....
3.1	Number of boats which are included in the total lifeboats shown above	.....
4	Liferafts complying with SOLAS regulations III/38 to 40 for which suitable means of launching are provided	.....
4.1	Number of liferafts	.....
4.2	Number of persons accommodated by them	.....
5	Open reversible liferafts (Annex 10 of the Code)	.....
5.1	Number of liferafts	.....
5.2	Number of persons accommodated by them	.....
6	Number of Marine Evacuation System (MES)	.....
6.1	Number of persons served by them	.....
7	Number of lifebuoys	.....
8	Number of lifejackets	.....
8.1	Number suitable for adults	.....
8.2	Number suitable for children	.....
9	Immersion suits	.....
9.1	Total number	.....
9.2	Number of suits complying with the requirements for lifejackets	.....
10	Number of anti-exposure suits	.....
10.1	Total number	.....

10.2	Number of suits complying with the requirements for lifejackets	.....
11	Radio installations used in life-saving appliances	
11.1	Number of radar transponders	.....
11.2	Number of two-way VHF radiotelephone apparatus	.....
3	<i>Details of radio facilities</i>	
	<b>Item</b>	<b>Actual provision</b>
1	Primary systems	..... ...
1.1	VHF radio installation:	..... ...
1.1.1	DSC encoder	..... ...
1.1.2	DSC Watch Receiver	..... ...
1.1.3	Radiotelephony	..... ...
1.2	MF radio installation:	..... ...
1.2.1	DSC encoder	..... ...
1.2.2	DSC watch receiver	..... ...
1.2.3	Radiotelephony	..... ...
1.3	MF/HF radio installation:	..... ...
1.3.1	DSC encoder	..... ...
1.3.2	DSC watch receiver	..... ...
1.3.3	Radiotelephony	..... ...
1.3.4	Direct-printing radiotelephony	..... ...
1.4	INMARSAT ship earth station	..... ...
2	Secondary means of alerting	..... ...
3	Facilities for reception of maritime safety information	..... ...

3.1	NAVTEX receiver	..... ...
3.2	EGC receiver	..... ...
3.3	HF direct-printing radiotelegraph receiver	..... ...
4	Satelite EPIRB	..... ...
4.1	COSPAS-SARSAT	..... ...
4.2	INMARSAT	..... ...
5	VHF EPIRB	..... ...
6	Ship's radar transponder	..... ...
7	Radiotelephone distress frequency watch receiver on 2, 182 khz	..... ...
8	Device for generating the radiotelephone alarm signal on 2, 182 khz	..... ...
4	Methods used to ensure availability of radio facilities (paragraphs 14.14.16, 14.14.7 and 14.14.8 of this Code)	
4.1	Duplication of equipment	.....
4.2	Shore-based maintenance	.....
4.3	At-sea maintenance capability	.....
THIS IS TO CERTIFY that this Record is correct in all respects		
(Place of issue of the record)		
.....		
.....		
(Date of issue)	(Signature of duly authorised official issuing the Record)	
	.....	
(Seal or stamp of the issuing authority, as appropriate)		
5	<i>Details of navigational systems and equipment</i>	
1.1	Magnetic compass	.....
1.2	Gyro-compass	.....

2	Speed and distance measuring device	.....
3	Echo-sounding device	.....
4.1	9 GHz radar	.....
4.2	Second radar (3 GHz/9 GHz )	.....
4.3	Automatic radar plotting aid (ARPA)/ Automatic tracking aid (ATA)	.....
5	Receiver for global navigation satellite system/Terrestrial navigation system/Other means of position fixing ,	.....
6.1	Rate-of-turn indicator	.....
6.2	Rudder angle indicator/Direction of steering thrust indicator	.....
7.1	Nautical charts/Electronic chart display and information system (ECDIS)	.....
7.2	Back up arrangements for ECDIS	.....
7.3	Nautical publications	.....
7.4	Back up arrangement for nautical publications	.....
8	Searchlight	.....
9	Daylight signalling lamp	.....
10	Night vision equipment	.....
11	Means to show the mode of the propulsion systems	.....
12	Automatic steering aid (Automatic pilot)	.....
13	Automatic identification system (AIS)	.....
14	Long-range identification and tracking system	.....
15	Voyage data recorder (VDR)	.....

THIS IS TO CERTIFY that this Record is correct in all respects

.....

(Place of issue of the record)

.....

..

(Date of issue)                      (Signature of duly authorised official issuing the Record)

.....

(Seal or stamp of the issuing authority, as appropriate)



# Annex 2 - For of Permit to Operate High Speed Craft

## 2.1.1 Permit to Operate High Speed Craft

Permit to Operate High Speed Craft

Issued under the provision of the

INTERNATIONAL CODE OF SAFETY FOR HIGH SPEED CRAFT

(Resolution MSC.....(63))

- 1 Name of craft.....
- 2 Manufacturer's model and hull number.....
- 3 Distinctive number or letters.....
- 4 IMO number\*.....
- 5 Port of registry.....
- 6 Category of craft.....
- 7 Name of operator.....
- 8 Areas or routes of operation.....
- 9 Base port (s).....
- 10 Maximum distance from place of refuge.....
- 11 Number of:.....
  - .1 Passengers maximum permitted.....
  - .2 Manning scale required .....
- 12 Worst intended conditions .....
- 13 Other operational restrictions .....

\* In accordance with the IMO ship identification number scheme adopted by the organisation by resolution A.600(15)

\*\* Delete as appropriate

This permit confirms that the service mentioned above has been found to be in accordance with the general requirements of 1.2.2 to 1.2.7 of the code.

THIS PERMIT is issued under the authority of the Government of

THIS PERMIT is valid until .....subject to the High Speed Craft Safety Certificate remaining valid

Issued at.....

(Place of issue of permit)

.....Signed.....

( Date of Issue) (Signature of authorised official issuing permit)

.....  
(Seal or stamp of the issuing authority, as appropriate)

## **Annex 3 - Use of Probability Concept**

### **1 General**

1.1. Absolute safety cannot be achieved in any human activity. Naturally, this fact should be taken into account in developing safety requirements, which means that requirements should not imply that safety is absolute. In the case of traditional craft, it has frequently been possible to specify certain aspects of design or construction in some detail, in a way which was consistent with some level of risk which had over the years been intuitively accepted without having to be defined.

1.2. For high speed craft, however, it would often be too restrictive to include engineering specifications into the Code. Requirements therefore need to be written (where this question arises) in the sense of "... the Administration should be satisfied on the basis of tests, investigations and past experience that the probability of ... is (acceptably low)". Since different undesirable events may be regarded as having different general orders of acceptable probability (e.g. temporary impairment of propulsion as compared with an uncontrollable fire), it is convenient to agree on a series of standardized expressions which can be used to convey the relative acceptable probabilities of various incidents, i.e. to perform a qualitative ranking process. A vocabulary is given below which is intended to ensure consistency between various requirements, where it is necessary to describe the level of risk which should not be exceeded.

### **2 Terms associated with probabilities**

. Different undesirable events may have different orders of acceptable probability. In connection with this, it is convenient to agree on standardized expressions to be used to convey the relatively acceptable probabilities of various occurrences, i.e. to perform a qualitative ranking process.

#### **2.1 Occurrences**

2.1.1. "Occurrence" is a condition involving a potential lowering of the level of safety.

2.1.2. "Failure" is an occurrence in which a part, or parts, of the craft fail or malfunction, e.g. runaway. A failure includes:

- .1. a single failure;
- .2. independent failures in combination within a system;
- .3. independent failures in combinations involving more than one system, taking into account:
  - .1. any undetected failure that is already present;
  - .2. such further failures as would be reasonably expected to follow the failure under consideration; and
  - .4. common cause failure (failure of more than one component or system due to the same cause).

2.1.3. "Event" is an occurrence which has its origin outside the craft (e.g. waves).

2.1.4. "Error" is an occurrence arising as a result of incorrect action by the operating crew or maintenance personnel.

#### **2.2 Probability of occurrences**

2.2.1. "Frequent" is one which is likely to occur often during the operational life of a particular craft.

2.2.2. "Reasonably probable" is one which is unlikely to occur often but which may occur several times during the total operational life of a particular craft.

2.2.3. "Recurrent" is a term embracing the total range of frequent and reasonably probable.

2.2.4. "Remote" is one which is unlikely to occur to every craft but may occur to a few craft of a type over the total operational life of a number of craft of the same type.

2.2.5. "Extremely remote" is one which is unlikely to occur when considering the total operational life of a number of craft of the type, but nevertheless should be considered as being possible.

2.2.6. "Extremely improbable" is one which is so extremely remote that it should not be considered as possible to occur.

## 2.3 Effects

2.3.1. "Effect" is a situation arising as a result of an occurrence.

2.3.2. "Minor effect" is an effect which may arise from a failure, an event, or an error, as defined in 2.1.2, 2.1.3, 2.1.4, which can be readily compensated for by the operating crew. It may involve:

- .1. a small increase in the operational duties of the crew or in their difficulty in performing their duties; or
- .2. a moderate degradation in handling characteristics; or
- .3. slight modification of the permissible operating conditions.

2.3.3. "Major effect" is an effect which produces:

- .1. a significant increase in the operational duties of the crew or in their difficulty in performing their duties which by itself should not be outside the capability of a competent crew provided that another major effect does not occur at the same time; or
- .2. significant degradation in handling characteristics; or
- .3. significant modification of the permissible operating conditions, but will not remove the capability to complete a safe journey without demanding more than normal skill on the part of the operating crew.

2.3.4. "Hazardous effect" is an effect which produces:

- .1. a dangerous increase in the operational duties of the crew or in their difficulty in performing their duties of such magnitude that they cannot reasonably be expected to cope with them and will probably require outside assistance; or
- .2. dangerous degradation of handling characteristics; or
- .3. dangerous degradation of the strength of the craft; or
- .4. marginal conditions for, or injury to, occupants; or
- .5. an essential need for outside rescue operations.

2.3.5. "Catastrophic effect" is an effect which results in the loss of the craft and/or in fatalities.

## 2.4 Safety level

"Safety level" is a numerical value characterizing the relationship between craft performance represented as horizontal single amplitude acceleration (g) and rate of acceleration (g/s) and the severity of acceleration-load effects on standing and sitting humans.

The safety levels and the corresponding severity of effects on passengers and safety criteria for craft performance should be as defined in table 1.

### 3 Numerical values

. Where numerical probabilities are used in assessing compliance with requirements using the terms similar to those given above, the following approximate values may be used as guidelines to assist in providing a common point of reference. The probabilities quoted should be on an hourly or per journey basis, depending on which is more appropriate to the assessment in question.

Frequent	More than $10^{-3}$
Reasonably probable	$10^{-3}$ to $10^{-5}$
Remote	$10^{-5}$ to $10^{-7}$
Extremely remote	$10^{-7}$ to $10^{-9}$
Extremely improbable	Whilst no approximate numerical probability is given for this, the figures used should be substantially less than $10^{-9}$

Note: Different occurrences may have different acceptable probabilities, according to the severity of their consequences (see table 2).

**Table 1 Table 1**

Effect	Criteria Not To Be Exceeded		Comments
	Type of Load	Value	
LEVEL 1 Minor Effect	Maximum acceleration measured horizontally	0.20 g	0.08 g and 0.20 g/s: Elderly person will keep balance when holding
Moderate degredation of safety		0.15 g and 0.20 g/s:	Mean person will keep balance when holding
		0.15 g and 0.20 g/s:	Sitting person will start holding
LEVEL 2 Major Effect	Maximum acceleration measured horizontally	0.35 g	0.25 g and 2.0 g/s: Maximum load for mean person keeping balance when holding
Significant degredation of safety		0.45 and 10 g/s:	Mean person falls out of seat when not wearing seat belts
LEVEL 3 Hazardous Effect	Collision design condition calculated	Ref. 4.3.3	Risk of injury to passengers , safe emergency operation after collison
Major Degredation of safety	Maximum structural design load, based on vertical acceleration at centre of gravity	Ref. 4.3.3	1.0 g: Degredation of passenger safety
LEVEL 4 Catastrophic Effect			Loss of craft or and fatalities

Safety Level	1	1	1	2	3	4
Effect on craft and occupants	Normal	Nuisance	Operating Limitations	Emergency procedures: significant reduction in safety margins; difficult for crew to cope with adverse conditions; passenger injuries	Large reduction in safety margins; crew over-burden because of workload or environmental conditions; serious injury to a small number of occupants.	Deaths, usually with loss of life
F.A.R Probability (reference only)	Probable	Probable	Probable	Improbable	Improbable	Extremely Improbable
	Probable	Probable	Probable	Improbable	Improbable	Extremely Improbable
JAR-25 Probability	Frequent	Frequent	Reasonably Probable	Remote	Extremely Remote	Improbable
Category of Effect	Minor	Minor	Minor	Major	Hazardous	Catastrophic
1, The United States Federal Aviation Regulations	2, European Joint Airworthiness regulations					

## Annex 4 - Procedures for Failure Mode and Effects Analysis

### 1 Introduction

1.1. In the case of traditional craft, it has been possible to specify certain aspects of design or construction in some level of detail, in a way which was consistent with some level of risk which had over the years been intuitively accepted without having to be defined.

1.2. With the development of large high speed craft, this required experience has not been widely available. However, with the now broad acceptance of the probabilistic approach to safety assessments within industry as a whole, it is proposed that an analysis of failure performance may be used to assist in the assessment of the safety of operation of high speed craft.

1.3. A practical, realistic and documented assessment of the failure characteristics of the craft and its component systems should be undertaken with the aim of defining and studying the important failure conditions that may exist.

1.4. This annex describes a failure mode and effects analysis (FMEA) and gives guidance as to how it may be applied by:

- .1. explaining basic principles;
- .2. providing the procedural steps necessary to perform an analysis;
- .3. identifying appropriate terms, assumptions, measures and failure modes; and
- .4. providing examples of the necessary worksheets.

1.5. FMEA for high speed craft is based on a single failure concept under which each system at various levels of a system's functional hierarchy is assumed to fail by one probable cause at a time. The effects of the postulated failure are analysed and classified according to their severity. Such effects may include secondary failures (or multiple failures) at other level(s). Any failure mode which may cause a catastrophic effect to the craft should be guarded against by system or equipment redundancy unless the probability of such failure is extremely improbable (refer to section 13). For failure modes causing hazardous effects corrective measures may be accepted in lieu. A test programme should be drawn to confirm the conclusions of FMEA.

1.6. Whilst FMEA is suggested as one of the most flexible analysis techniques, it is accepted that there are other methods which may be used and which in certain circumstances may offer an equally comprehensive insight into particular failure characteristics.

## 2 Objectives

2.1. The primary objective of FMEA is to provide a comprehensive, systematic and documented investigation which establishes the important failure conditions of the craft and assesses their significance with regard to the safety of the craft, its occupants and the environment.

2.2. The main aims of undertaking the analysis are to:

.1. provide the Administration with the results of a study into the craft's failure characteristics so as to assist in an assessment of the levels of safety proposed for the craft's operation;

.2. provide craft operators with data to generate comprehensive training, operational and maintenance programmes and documentation; and

.3. provide craft and system designers with data to audit their proposed designs.

## 3 Scope of application

3.1. FMEA should be conducted for each high speed craft, before its entry into service, in respect of the systems as required under the provisions of 5.2,9.1.10, 12.1.1 and 16.2.6 of this Code.

3.2. For craft of the same design and having the same equipment, one FMEA on the lead craft will be sufficient, but each of the craft should be subject to the same FMEA conclusion trials.

## 4 System failure mode and effects analysis

4.1. Before proceeding with a detailed FMEA into the effects of the failure of the system elements on the system functional output it is necessary to perform a functional failure analysis of the craft's important systems. In this way only systems which fail the functional failure analysis need to be investigated by a more detailed FMEA.

4.2. When conducting a system FMEA the following typical operational modes within the normal design environmental conditions of the craft should be considered:

.1. normal seagoing conditions at full speed;

.2. maximum permitted operating speed in congested waters; and

.3. manoeuvring alongside.

4.3. The functional interdependence of these systems should also be described in either block diagrams or fault tree diagrams or in a narrative format to enable the failure effects to be understood. As far as applicable, each of the systems to be analysed is assumed to fail in the following failure modes:

.1. complete loss of function;

.2. rapid change to maximum or minimum output;

.3. uncontrolled or varying output;

- .4. premature operation;
- .5. failure to operate at a prescribed time; and
- .6. failure to cease operation at a prescribed time.

Depending on the system under consideration other failure modes may have to be taken into account.

4.4. If a system can fail without any hazardous or catastrophic effect, there is no need to conduct a detailed FMEA into the system architecture. For systems whose individual failure can cause hazardous or catastrophic effects and where a redundant system is not provided, a detailed FMEA as described in the following paragraphs should be followed. Results of the system functional failure analysis should be documented and confirmed by a practical test programme drawn up from the analysis.

4.5. Where a system, the failure of which may cause a hazardous or catastrophic effect, is provided with a redundant system, a detailed FMEA may not be required provided that:

- .1. the redundant system can be put into operation or can take over the failed system within the time-limit dictated by the most onerous operational mode in 4.2 without hazarding the craft;
- .2. the redundant system is completely independent from the system and does not share any common system element the failure of which would cause failure of both the system and the redundant system. Common system element may be acceptable if the probability of failure complies with section 13; and
- .3. the redundant system may share the same power source as the system. In such case an alternative power source should be readily available with regard to the requirement of .1.

The probability and effects of operator error to bring in the redundant system should also be considered.

## **5 Equipment failure mode and effects analysis**

. The systems to be subject to a more detailed FMEA investigation at this stage should include all those that have failed the system FMEA and may include those that have a very important influence on the safety of the craft and its occupants and which require an investigation at a deeper level than that undertaken in the system functional failure analysis. These systems are often those which have been specifically designed or adapted for the craft, such as the craft's electrical and hydraulic systems.

## **6 Procedures**

. The following steps are necessary to perform FMEA:

- .1. to define the system to be analysed;
- .2. to illustrate the interrelationships of functional elements of the system by means of block diagrams;
- .3. to identify all potential failure modes and their causes;
- .4. to evaluate the effects on the system of each failure mode;
- .5. to identify failure detection methods;
- .6. to identify corrective measures for failure modes;
- .7. to assess the probability of failures causing hazardous or catastrophic effects, where applicable;
- .8. to document the analysis;
- .9. to develop a test programme;

.10. to prepare FMEA report.

## 7 System definition

. The first step in an FMEA study is a detailed study of the system to be analysed through the use of drawings and equipment manuals. A narrative description of the system and its functional requirements should be drawn up including the following information:

- .1. general description of system operation and structure;
- .2. functional relationship among the system elements;
- .3. acceptable functional performance limits of the system and its constituent elements in each of the typical operational modes: and
- .4. system constraints.

## 8 Development of system block diagrams

8.1. The next step is to develop block diagram(s) showing the functional flow sequence of the system, both for technical understanding of the functions and operation of the system, and for the subsequent analysis. As a minimum the block diagram should contain:

- .1. breakdown of the system into major sub-systems or equipment;
- .2. all appropriate labelled inputs and outputs and identification numbers by which each sub-system is consistently referenced; and
- .3. all redundancies, alternative signal paths and other engineering features which provide "fail-safe" measures.

An example of a system block diagram is given at appendix 1.

8.2. It may be necessary to have a different set of block diagrams prepared for each operational mode.

## 9 Identification of failure modes, causes and effects

9.1. Failure mode is the manner by which a failure is observed. It generally describes the way the failure occurs and its impact on the equipment or system. As an example, a list of failure modes is given in table 1. The failure modes listed in table 1 can describe the failure of any system element in sufficiently specific terms. When used in conjunction with performance specifications governing the inputs and outputs on the system block diagram, all potential failure modes can be thus identified and described. Thus, for example, a power supply may have a failure mode described as "loss of output"(29), and a failure cause "open (electrical)"(31).

**Table 1 Example of a set of Failure Modes**

1	Structural Failure (Rupture)	18	False Actuation
2	Physical binding or jamming	19	Fails to stop
3	Vibration	20	Fails to start
4	Fails to remain in position	21	Fails to switch
5	Fails to open	22	Premature operation
6	Fails to close	23	Delayed operation



7	Fails open	24	Erroneous input (increased)
8	Fails closed	25	Erroneous input (decreased)
9	Internal leakage	26	Erroneous output (increased)
10	External leakage	27	Erroneous output (decreased)
11	Fails out of tolerance (high)	28	Loss of input
12	Fails out of tolerance (low)	29	Loss of output
13	Inadvertant operation	30	Shorted (Electrical)
14	intermittent operation	31	Open (Electrical)
15	Erratic operation	32	Leakage (Electrical)
16	Erroneous	33	Other unique failure conditions as applicable to the system characteristics, requirements and operational constraints.
17	Restricted flow		

9.2. A failure mode in a system element could also be the failure cause of a system failure. For example, the hydraulic line of a steering gear system might have a failure mode of "external leakage"(10). This failure mode of the hydraulic line could become a failure cause of the steering gear system's failure mode "loss of output"(29).

9.3. Each system should be considered in a top-down approach, starting from the system's functional output, and failure should be assumed by one possible cause at a time. Since a failure mode may have more than one cause, all potential independent causes for each failure mode should be identified.

9.4. If major systems can fail without any adverse effect there is no need to consider them further unless the failure can go undetected by an operator. To decide that there is no adverse effect does not mean just the identification of system redundancy. The redundancy should be shown to be immediately effective or brought on line with negligible time lag. In addition, if the sequence is:

"failure-alarm-operator action - start of back up - back up in service", the effects of delay should be considered.

## 10 Failure effects

10.1. The consequence of a failure mode on the operation, function, or status of an equipment or a system is called a "failure effect". Failure effects on a specific sub-system or equipment under consideration are called "local failure effects". The evaluation of local failure effects will help to determine the effectiveness of any redundant equipment or corrective action at that system level. In certain instances, there may not be a local effect beyond the failure mode itself.

10.2. The impact of an equipment or sub-system failure on the system output (system function) is called an "end effect". End effects should be evaluated and their severity classified in accordance with the following categories:

- .1. catastrophic;
- .2. hazardous;
- .3. major; and
- .4. minor.

The definitions of these four categories of failure effects are given in 2.3 of annex 3 of this Code.

10.3. If the end effect of a failure is classified as hazardous or catastrophic, back-up equipment is usually required to prevent or minimize such effect. For hazardous failure effects corrective operational procedures may be accepted.

## 11 Failure detection

11.1. The FMEA study in general only analyses failure effects based on a single failure in the system and therefore a failure detection means, such as visual or audible warning devices, automatic sensing devices, sensing instrumentation or other unique indications should be identified.

11.2. Where the system element failure is non-detectable (i.e. a hidden fault or any failure which does not give any visual or audible indication to the operator) and the system can continue with its specific operation, the analysis should be extended to determine the effects of a second failure, which in combination with the first undetectable failure may result in a more severe failure effect, e.g., hazardous or catastrophic effect.

## 12 Corrective measures

12.1. The response of any back-up equipment, or any corrective action initiated at a given system level to prevent or reduce the effect of the failure mode of a system element or equipment, should also be identified and evaluated.

12.2. Provisions which are features of the design at any system level to nullify the effects of a malfunction or failure, such as controlling or deactivating system elements to halt generation or propagation of failure effects, or activating back-up or standby items or systems, should be described. Corrective design provisions include:

- .1. redundancies that allow continued and safe operation;
- .2. safety devices, monitoring or alarm provisions, which permit restricted operation or limit damage; and
- .3. alternative modes of operation.

12.3. Provisions which require operator action to circumvent or mitigate the effects of the postulated failure should be described. The possibility and effect of operator error should be considered, if the corrective action or the initiation of the redundancy requires operator input, when evaluating the means to eliminate the local failure effects.

12.4. It should be noted that corrective responses acceptable in one operational mode may not be acceptable at another, e.g., a redundant system element with considerable time lag to be brought into line, while meeting the operational mode "normal seagoing conditions at full speed" may result in a catastrophic effect in another operational mode, e.g., "maximum permitted operating speed in congested water".

## 13 Use of probability concept

13.1. If corrective measures or redundancy as described in preceding paragraphs are not provided for any failure, as an alternative the probability of occurrence of such failure should meet the following criteria of acceptance:

- .1. a failure mode which results in a catastrophic effect should be assessed to be extremely improbable;
- .2. a failure mode assessed as extremely remote should not result in worse than hazardous effects;
- .3. a failure mode assessed as either frequent or reasonably probable should not result in worse than minor effects.

13.2. Numerical values for various levels of probabilities are laid down in section 3 of annex 3 of this Code. In areas where there is no data from craft to determine the level of probabilities of failure other sources can be used such as:

- .1. workshop test, or
- .2. history of reliability used in other areas under similar operating conditions, or

.3. mathematical model if applicable.

## 14 Documentation

14.1. It is helpful to perform FMEA on worksheet(s) as shown in appendix 2.

14.2. The worksheets(s) should be organized to first display the highest system level and then proceed down through decreasing system levels

## 15 Test programme

15.1. An FMEA test programme should be drawn up to prove the conclusions of FMEA. It is recommended that the test programme should include all systems or system elements whose failure would lead to:

- .1. major or more severe effects;
- .2. restricted operations; and
- .3. any other corrective action.

For equipment where failure cannot be easily simulated on the craft, the results of other tests can be used to determine the effects and influences on the systems and craft.

15.2. The trials should also include investigations into:

- .1. the layout of control stations with particular regard to the relative positioning of switches and other control devices to ensure a low potential for inadvertent and incorrect crew action, particularly during emergencies, and the provision of interlocks to prevent inadvertent operation for important system operation;
- .2. the existence and quality of the craft's operational documentation with particular regard to the pre-voyage checklists. It is essential that these checks account for any unrevealed failure modes identified in the failure analysis; and
- .3. the effects of the main failure modes as prescribed in the theoretical analysis.

15.3. The FMEA tests on board should be conducted in conjunction with provisions specified in 5.3, 16.4 and 17.4 of this Code, before the craft enters into service.

## 16 FMEA Report

. The FMEA report should be a self-contained document with a full description of the craft, its systems and their functions and the proposed operation and environmental conditions for the failure modes, causes and effects to be understood without any need to refer to other plans and documents not in the report. The analysis assumptions and system block diagrams should be included, where appropriate. The report should contain a summary of conclusions and recommendations for each of the systems analysed in the system failure analysis and the equipment failure analysis. It should also list all probable failures and their probability of failure, where applicable, the corrective actions or operational restrictions for each system in each of the operational modes under analysis. The report should contain the test programme, reference any other test reports and the FMEA trials.

# Appendix 1 - Example of a System Block Diagram

Steering Control System

Date .....

Analyst .....

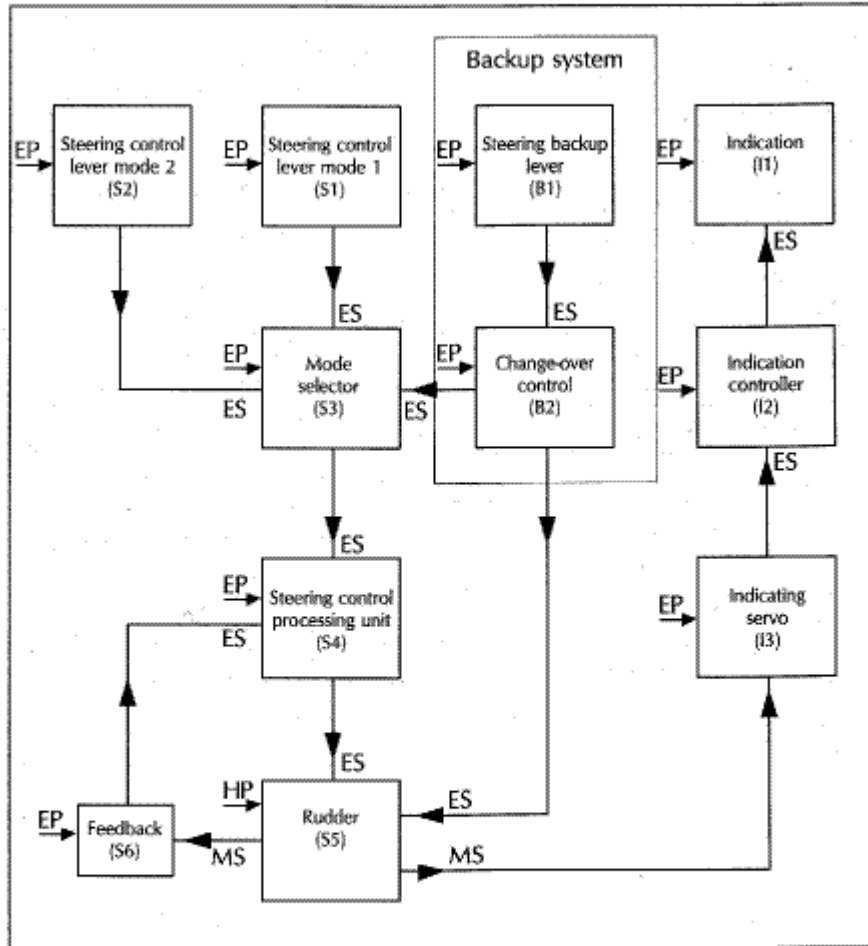

where:

- EP - electric power
- HP - hydraulic power
- ES - electric signal
- MS - mechanical signal

Figure 1. Example of a System Block Diagram

## Appendix 2 - FMEA Worksheet

. To view the FMEA Worksheet, please click here.

Table 2 FMEA WORKSHEET

Name of System	References
Mode of Operation	System Block

Diagrams										
Sheet of Operaton _____										
Date _____										
Name of analyst _____ Drawings _____										
Equipment name or number	Function	Indent .No.	Failure cause	Failure Effect		Failure Detection	Corrective action	Severity of failure effect	Probability of failure (if applicable)	Remarks
				Local Effect	End Effect					

## Annex 5 - Ice Accretion Applicable to all Types of Craft

### 1 Icing allowances

1.1. For craft operating in areas where ice accretion is likely to occur the following icing allowance should be made in the stability calculations:

- .1. 30 kg/m<sup>2</sup> on exposed weather decks and gangways;
- .2. 7.5 kg/m<sup>2</sup> for projected lateral area of each side of the craft above the waterplane;
- .3. the projected lateral area of discontinuous surfaces of rail, sundry booms, spars (except masts) and rigging and the projected lateral area of other small objects should be computed by increasing the total projected area of continuous surfaces by 5% and the static moments of this area by 10%;
- .4. reduction of stability due to asymmetric ice accumulations in cross-structure.

1.2. For craft operating in areas where ice accretion may be expected:

- .1. Within the areas defined in 2.1, 2.3, 2.4 and 2.5 known to have icing conditions significantly different from those in 1.1, ice accretion requirements of one half to twice the required allowance may be applied.
- .2. Within the area defined in 2.2, where ice accretion in excess of twice the allowance required by 1.1 may be expected, more severe requirements than those given in 1.1 may be applied.

1.3. Information should be provided in respect of the assumptions made in calculating the condition of the craft in each of the circumstances set out in this annex for the following:

- .1. duration of the voyage in terms of the period spent in reaching the destination and returning to port; and
- .2. consumption rates during the voyage for fuel, water, stores and other consumables.

### 2 Areas of icing conditions

. In the application of 1, the following icing areas should apply:

.1. The area north of latitude 65°30'N, between longitude 28°W and the West coast of Iceland; north of the north coast of Iceland; north of the rhumb line running from latitude 66°N, longitude 15°W to latitude 73°30'N, longitude 15°E, north of latitude 73°30'N between longitude 15°E and 35°E, and east of longitude 35°E, as well as north of latitude 56°N in the Baltic Sea.

.2. The area north of latitude 43°N bounded in the west by the North American coast and the east by the rhumb line running from latitude 43°N, longitude 48°W to latitude 63°N, longitude 28°W and thence along longitude 28°W.

.3. All sea areas north of the North American continent, west of the areas defined in subparagraphs .1 and .2 of this paragraph.

.4. The Bering and Okhotsk Seas and the Tartary Strait during the icing season.

.5. South of latitude 60°S.

A chart to illustrate the areas is attached.

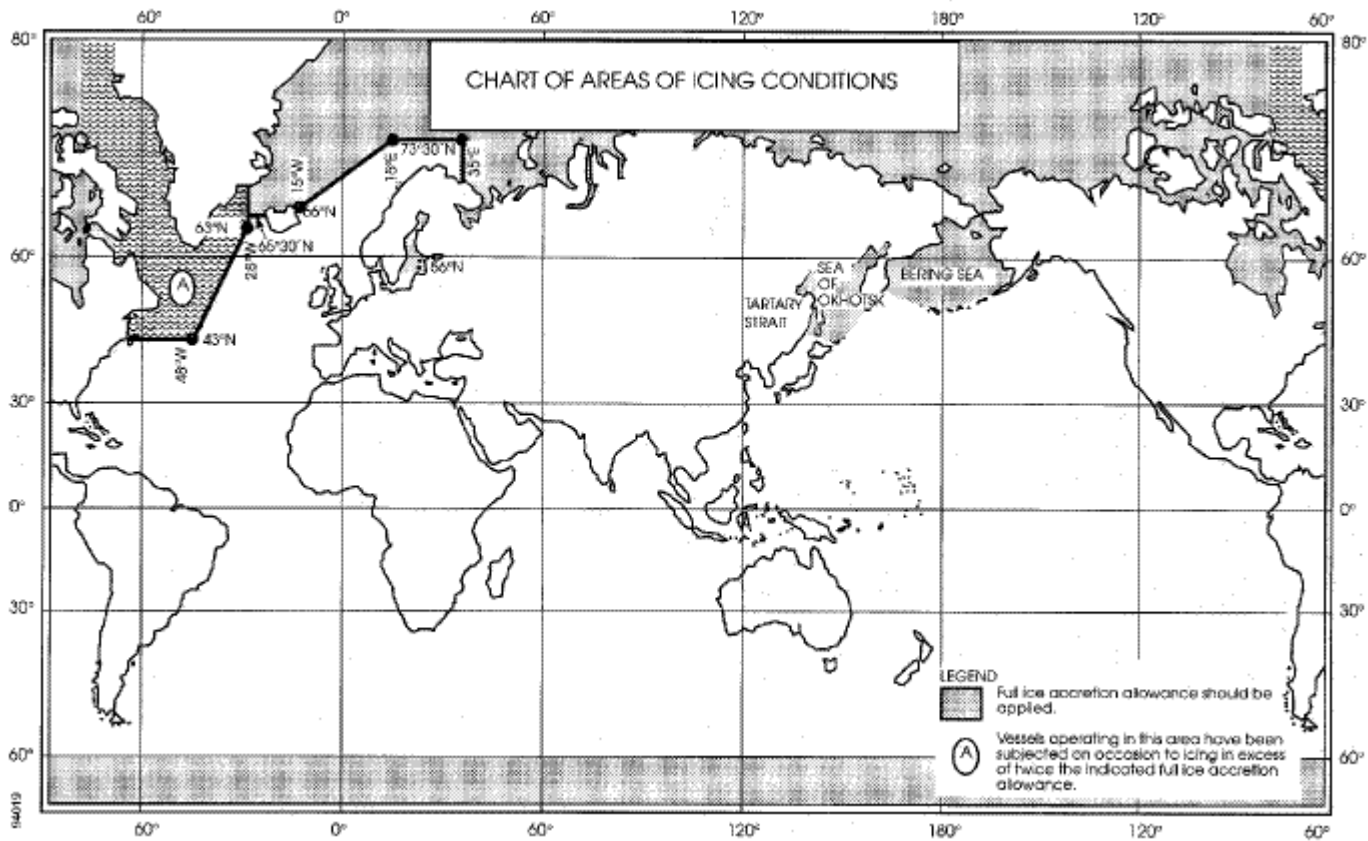

**Figure 1. Chart of Areas of Icing Conditions**

### 3 Special requirements

- . Craft intended for operation in areas where ice accretion is known to occur should be:
  - .1. designed to minimize the accretion of ice; and
  - .2. equipped with such means for removing ice as the Administration may require.

# Annex 6 - Methods Relating to the Intact Stability Investigation of Hydrofoil Craft

. The stability of these crafts should be considered in the hull-borne, transient and foil-borne modes. The stability investigation should also take into account the effects of external forces. The following procedures are outlined for guidance in dealing with stability.

## 1 Surface-piercing hydrofoils

### 1.1 Hull-borne mode

1.1.1. The stability should be sufficient to satisfy the provisions of 2.3 and 2.4 of this Code.

1.1.2. Heeling moment due to turning

The heeling moment developed during manoeuvring of the craft in the displacement mode may be derived from the following formula:

$$M_R = 0.196 \frac{V_o^2}{L} \cdot \Delta \cdot KG \text{ (KNm)}$$

where:

$M_R$  = moment of heeling;

$V_o$  = speed of the craft in the turn (m/s)

$\Delta$  = displacement (t);

$L$  = length of the craft on the waterline (m)

$KG$  = height of the centre of gravity above keel (m).

This formula is applicable when the ratio of the radius of the turning circle to the length of the craft is 2 to 4.

1.1.3. Relationship between the capsizing moment and heeling moment to satisfy the weather criterion

The stability of a hydrofoil boat in the displacement mode can be checked for compliance with the weather criterion  $K$  as follows:

$$K = \frac{M_c}{M_v} \geq 1$$

where:

$M_c$  = minimum capsizing moment as determined when account is taken of rolling;

$M_v$  = dynamically applied heeling moment due to the wind pressure.

1.1.4. Heeling moment due to wind pressure

The heeling moment  $M_v$  is a product of wind pressure  $P_v$ , the windage area  $A_v$  and the lever of windage area  $Z$ .

$$M_v = 0.001 P_v A_v Z \text{ (kNm)}$$

The value of the heeling moment is taken as constant during the whole period of heeling.

The windage area  $A_v$  is considered to include the projections of the lateral surfaces of the hull, superstructure and various structures above the waterline. The windage area lever  $Z$  is the vertical distance to the centre of windage from the waterline and the position of the centre of windage may be taken as the centre of the area.

The values of the wind pressure in Pascal associated with Force 7 Beaufort Scale depending on the position of the centre of windage area are given in table 1.

Table 1

Typical wind pressures for Beaufort scale 7, 100 nautical miles from land

Z above waterline (m)	1.0	1.5	2.0	2.5	3.0	3.5	4.0	4.5	5.0
P <sub>v</sub> (Pa)	46	46	50	53	56	58	60	62	64

Note: These values may not be applicable in all areas.

1.1.5. Evaluation of the minimum capsizing moment M<sub>c</sub> in the displacement mode

The minimum capsizing moment is determined from the static and dynamic stability curves taking rolling into account.

.1. When the static stability curve is used, M<sub>c</sub> is determined by equating the areas under the curves of the capsizing and righting moments (or levers) taking rolling into account, as indicated by figure 1, where θ<sub>z</sub> is the amplitude of roll and MK is a line drawn parallel to the abscissa axis such that the shaded areas S<sub>1</sub> and S<sub>2</sub> are equal.

M<sub>c</sub> = OM, if the scale of ordinates represents moments,

M<sub>c</sub> = OM x Displacement, if the scale of ordinates represents levers.

.2. When the dynamic stability curve is used, first an auxiliary point A should be determined. For this purpose the amplitude of heeling is plotted to the right along the abscissa axis and a point A' is found (see figure 2). A line AA' is drawn parallel to the abscissa axis equal to the double amplitude of heeling (AA' = 2θ<sub>z</sub>) and the required auxiliary point A is found. A tangent AC to the dynamic stability curve is drawn. From the point A the line AB is drawn parallel to the abscissa axis and equal to 1 radian (57.3°). From the point B a perpendicular is drawn to intersect with the tangent in point E. The distance BE is equal to the capsizing moment if measured along the ordinate axis of the dynamic stability curve. If, however, the dynamic stability levers are plotted along this axis, BE is then the capsizing lever, and in this case the capsizing moment M<sub>c</sub> is determined by multiplication of ordinate BE (in metres) by the corresponding displacement in tonnes

$$M_c = 9.81 \Delta \frac{BE}{g} \text{ (kNm)}$$

.3. The amplitude of rolling θ<sub>z</sub> is determined by means of model and full-scale tests in irregular seas as a maximum amplitude of rolling of 50 oscillations of a craft travelling at 90° to the wave direction in sea state for the worst design condition. If such data are lacking the amplitude is assumed to be equal to 15°.

.4. The effectiveness of the stability curves should be limited to the angle of flooding.

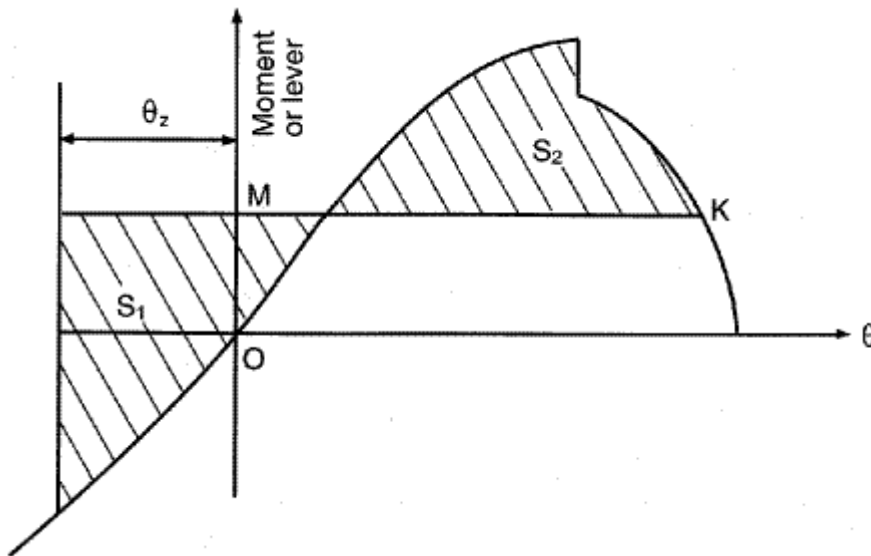



**Figure 1 Static Stability Curve**

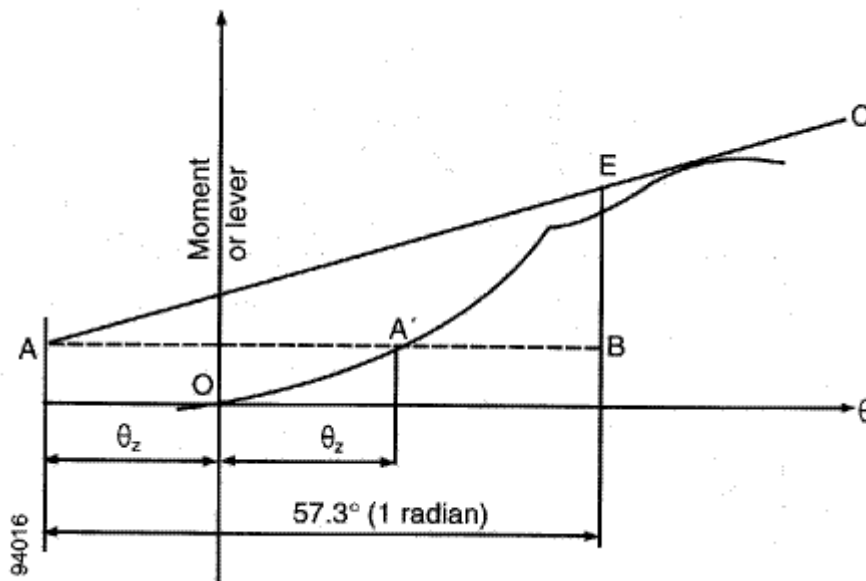

**Figure 2 Dynamic Stability Curve**

## 1.2 Transient and foil-borne modes

1.2.1. The stability should satisfy the provisions of 2.4 and 2.5 of this Code.

1.2.2.1. The stability in the transient and foil-borne modes should be checked for all cases of loading for the intended service of the craft.

1.2.2.2. The stability in the transient and foil-borne modes may be determined either by calculation or on the basis of data obtained from model experiments and should be verified by full-scale tests by the imposition of a series of known heeling moments by off-centre ballast weights, and recording the heeling angles produced by these moments. When taken in the hull-borne, take-off, steady foil-borne and settling to hull-borne modes, these results will provide an indication of the values of the stability in the various situations of the craft during the transient condition.

1.2.2.3. The angle of heel in the foil-borne mode caused by the concentration of passengers at one side should not exceed  $8^\circ$ . During the transient mode the angle of heel due to the concentration of passengers on one side should not exceed  $12^\circ$ . The concentration of passengers should be determined by the Administration, having regard to the guidance given at annex 7 to this Code.

1.2.3. One of the possible methods of assessing foil-borne metacentric height (GM) in the design stage for a particular foil configuration is given in figure 3.

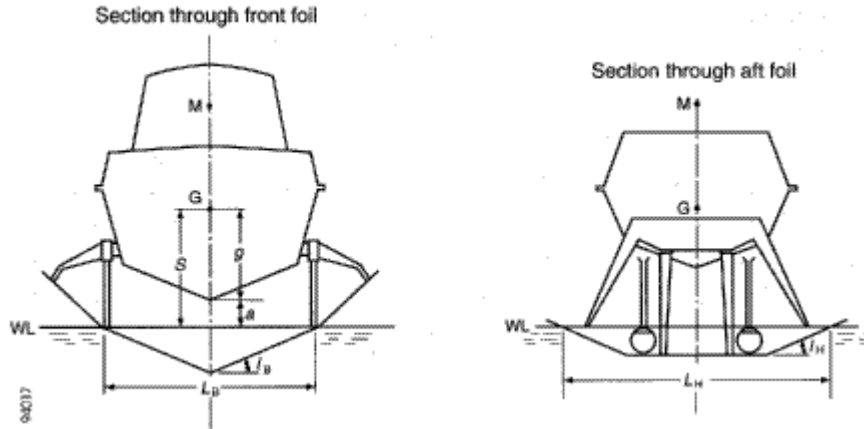

Figure 3

## 2 Fully submerged hydrofoils

### 2.1 Hull-borne mode

2.1.1. The stability in the hull-borne mode should be sufficient to satisfy the provisions of 2.3 and 2.6 of this Code.

2.1.2. Paragraphs 1.1.2 to 1.1.5 of this annex are appropriate to this type of craft in the hull-borne mode.

### 2.2 Transient mode

2.2.1. The stability should be examined by the use of verified computer simulations to evaluate the craft's motions, behaviour and responses under the normal conditions and limits of operation and under the influence of any malfunction.

2.2.2. The stability conditions resulting from any potential failures in the systems or operational procedures during the transient stage which could prove hazardous to the craft's watertight integrity and stability should be examined.

### 2.3 Foil-borne mode

. The stability of the craft in the foil-borne mode should be in compliance with the provisions of 2.4 of this Code. The provisions of paragraph 2.2 of this annex should also apply.

. Paragraph 1.2.2 of this annex should be applied to this type of craft as appropriate and any computer simulations or design calculations should be verified by full-scale tests.

## Annex 7 - Stability of Multihull Craft

### 1 Stability criteria in the intact condition

. A multihull craft, in the intact condition, should have sufficient stability when rolling in a seaway to successfully withstand the effect of either passenger crowding or high speed turning as described in 1.4. The craft's stability should be considered to be sufficient p. The area (A1) under the GZ curve up to an angle  $\Theta$  should be at least:

$$A1 = 0.055 \times 30^\circ / \Theta \text{ (m.rad)}$$

where:

$\Theta$  is the least of the following angles:

. 1. the downflooding angle:

.2. the angle at which the maximum GZ occurs: and

.3. 30°.

## 1.2 Maximum GZ

. The maximum GZ value should occur at an angle of at least 10°.

## 1.3 Heeling due to wind

. The wind heeling lever should be assumed constant at all angles of inclination and should be calculated as follows:

$$HL1 = \frac{P_i \cdot A \cdot Z}{9800 \Delta} \text{ (m) (see figure 1)}$$

$$HL2 = 1.5 HL1 \text{ (m) (see figure 1)}$$

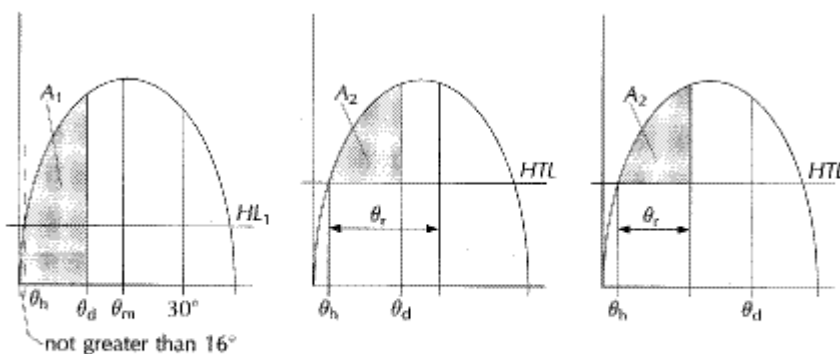

$HL_1$  = Heeling lever due to wind

$HTL$  = Heeling lever due to wind + gusting + (passenger crowding or turning)

## Figure 1 Intact stability

where:

$P_i = 500$  (Pa)

$A$  = projected lateral area of the portion of the ship above the lightest service waterline ( $m^2$ )

$Z$  = vertical distance from the centre of  $A$  to a point one half the lightest service draught (m)

$\Delta$  = displacement (t)

## 1.4 Heeling due to passenger crowding or high speed turning

. Heeling due to the crowding of passengers on one side of the craft or to high speed turning, whichever is the greater should be applied in combination with the heeling lever due to wind ( $HL_2$ ).

.1. Heeling due to passenger crowding

When calculating the magnitude of the heel due to passenger crowding, a passenger crowding lever should be developed using the assumptions stipulated in 2.10 of this Code.

.2. Heeling due to high speed turning

When calculating the magnitude of the heel due to the effects of high speed turning, a high speed turning lever should be developed using the following formula:

$$TL = \frac{1}{g} \frac{V_o^2}{R} \left( KG - \frac{d}{2} \right) \quad (m)$$

where:

TL = turning lever (m)

Vo = speed of craft in the turn (m/s)

R = turning radius (m)

KG = height of vertical centre of gravity above keel (m)

d = mean draught (m)

## 1.5 Rolling in waves

. The effect of rolling in a seaway upon the craft's stability should be demonstrated mathematically. In doing so, the residual area under the GZ curve (A2), i.e. beyond the angle of heel ( $\Theta_h$ ), should be at least equal to 0.028 m.rad up to the angle of roll  $\Theta_r$ . In the absence of model test or other data  $\Theta_r$  should be taken as 15° or an angle of  $(\Theta_d - \Theta_h)$ , whichever is less.

## 2 Criteria for residual stability after damage

2.1. The method of application of criteria to the residual stability curve is similar to that for intact stability except that the craft in the final condition after damage should be considered to have an adequate standard of residual stability provided:

- .1. the required area A2 should be not less than 0.028 m.rad ( figure 2 refers); and
- .2. there, is no requirement regarding the angle at which the maximum GZ value should occur.

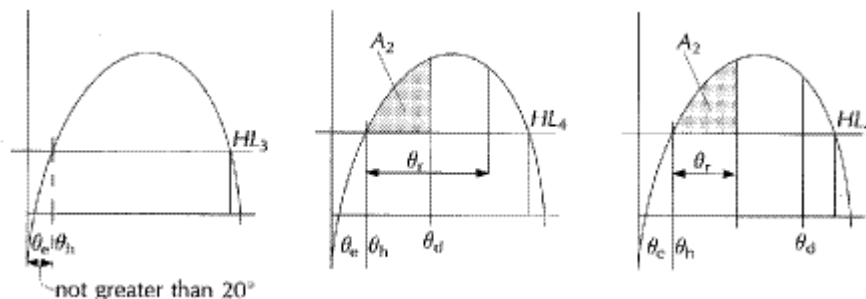

**Figure 2 Damage stability**

2.2. The wind heeling lever for application on the residual stability curve should be assumed constant at all angles of inclination and should be calculated as follows:

$$HL3 = \frac{P_d \cdot A \cdot Z}{9800 \Delta}$$

where:

$P_d = 120$  (Pa)

A = projected lateral area of the portion of the ship above the lightest service waterline (m<sup>2</sup>)

Z = vertical distance from the centre of A to a point one half of the lightest service draught (m)

$\Delta$  = displacement (t)

2.3. The same values of roll angle should be used as for the intact stability.

2.4. The downflooding point is important and is regarded as terminating the residual stability curve. The area A2

should therefore be truncated at the downflooding angle.

2.5. The stability of the craft in the final condition after damage should be examined and shown to satisfy the criteria, when damaged as stipulated in 2.6 of this Code.

2.6. In the intermediate stages of flooding, the maximum righting lever should be at least 0.05 m and the range of positive righting lever should be at least 7°. In all cases, only one breach in the hull and only one free surface need to be assumed.

## **3 Application of heeling levers**

### **3.1 In applying the heeling levers to the intact and damaged curves the following should be considered:**

3.1.1. for intact condition:

.1. wind heeling lever - steady wind (HLI); and

.2. wind heeling lever (including gusting effect) plus either the passenger crowding or speed turning levers whichever is the greater (HTL).

3.1.2. for damage condition:

.1. wind heeling lever - steady wind (HL3); and

.2. wind heeling lever plus heeling lever due to passenger crowding (HL4).

### **3.2 Angles of heel due to steady wind**

3.2.1. The angles of heel due to steady wind when the heeling lever HLI, obtained as in 1.3, is applied to the intact stability curve, should not exceed 16°, and

3.2.2. The angle of heel due to steady wind when the heeling lever HL3, obtained as in 2.2, is applied to the residual stability curve, after damage, should not exceed 20°.

## **Annex 8 - Definitions, Requirements and Compliance Criteria Related to Operational and Safety Performance**

. This annex applies to all types of craft. Tests to evaluate operational safety should be conducted on the prototype craft of a new design or of a design incorporating new features which may modify the results of a previous testing. The tests should be carried out to a schedule agreed between the Administration and the manufacturer. Where conditions of service warrant additional testing (e.g., low temperature), the Administration or base port State authorities as appropriate may require further demonstrations. Functional descriptions, technical and system specifications relevant to the understanding and evaluation of craft performance should be available.

The objective of these tests is to provide essential information and guidance to enable the craft to be operated safely under normal and emergency conditions within the design speed and environmental envelope.

The following procedures are outlined as requirements in dealing with verification of craft performance.

## **1 Performance**

### **1.1 General**

1.1.1. The craft should meet the applicable operational requirements in chapter 17 of this Code and this annex for all extremes of passenger and load configurations for which certification is required. The limiting sea state related

to the different modes of operation should be verified by tests and analyses of a craft of the type for which certification is requested.

1.1.2. Operational control of the craft should be in accordance with procedures established by the applicant for operation in service. Procedures to be established should be start procedure, cruise procedures, normal and emergency stop and manoeuvre procedures.

1.1.3. The procedures established under 1.1.2 should:

- .1. demonstrate that normal manoeuvres and craft responses to failures are consistent in performance;
- .2. use methods or devices that are safe and reliable; and
- .3. include allowance for any time lag in the execution of procedures that may reasonably be expected in service.

1.1.4. Procedures required by this annex should be conducted over water of sufficient depth such that craft performance will not be affected.

1.1.5. Tests should be conducted at minimum practicable weight and additional testing should be conducted at maximum weight sufficient to establish the need for additional restrictions and for testing to examine the effect of weight.

## 2 Stopping

2.1. This test is to establish the acceleration experienced when stopping the craft in calm water with no passenger load or cargo load during the following conditions:

- .1. normal stop for maximum operational speed;
- .2. emergency stop for maximum operational speed; and
- .3. crash stop from maximum operational speed and from any transient mode speed.

2.2. The tests referred to in 2.1.1 and 2.1.2 should document that the accelerations do not exceed safety level 1 in annex 3 when control levers are used in accordance to written procedures as given in the craft operating manual or in an automatic mode. Should safety level 1 be exceeded during normal stop, control systems should be modified in order to avoid exceedance or passengers should be required to be seated during normal stop. Should safety level 1 be exceeded during emergency stop, then written procedures in the craft operating manual should include detailed information of how to avoid exceedance or control system should be modified to avoid exceedance.

2.3. The test referred to in 2.1.3 should document that the accelerations do not exceed safety level 2 of annex 3 when control levers of automatic modes are used in a manner which will give the highest accelerations. If safety level 2 is exceeded then the craft operating manual should include a warning that it is a risk to passengers being injured, if crash stop is performed.

2.4. Other tests should be repeated during craft turning to establish the need or otherwise to impose any speed related restrictions during manoeuvres.

## 3 Cruise performance

3.1. This test is to establish the craft performance and accelerations experienced during cruise modes with no passenger load or cargo load during the following conditions:

- .1. normal operation conditions are those in which the craft will safely cruise at any heading while manually operated, auto-pilot assisted operated or operated with any automatic control system in normal mode; and
- .2. worst intended conditions, referred to in 1.4.48 of this Code, are those in which it should be possible to maintain safe cruise without exceptional piloting skill. However, operations at all headings relative to the wind and sea may not be possible. For type of craft having a higher performance standard in non-displacement mode, the

performance and accelerations should also be established at displacement mode during operation in the worst intended condition.

3.2. Operation levels, as defined in 3.1, should be established and documented by full-scale tests in at least two relevant sea conditions and in head, beam and following seas. Test period should be at least 15 min. Model tests and mathematical simulations could be used to verify the performance in the worst intended conditions.

Limits for normal operation condition should be documented by measurements of craft speed, heading to the wave and interpolation of measurements of maximum horizontal accelerations in accordance with 2.4 of annex 3. Measurement of wave height and period should be made to the maximum extent practicable.

Limits for worst intended condition should be documented by measurements of craft speed, wave height and period, heading to the wave and by root mean square (RMS) values of horizontal accelerations in accordance with 2.4 of annex 3 and of vertical accelerations close to the craft longitudinal centre of gravity. RMS values could be used for extrapolation of peak values. To obtain the expected peak values related to structural design load and safety levels (1 per 5-min exceedance), multiply the RMS values by 3.0 or

$$C = \sqrt{2 \ln N}$$

where:

N is the number of successive amplitudes within the relevant period.

If not otherwise verified by model tests or by mathematical calculations, it might be assumed a linear relation between wave height and accelerations based on measurements in the two sea conditions. Limits for worst intended condition should be documented both related to passenger safety in accordance with 2.4 of annex 3 and related to the actual structural design load of the craft.

3.3. The tests and verification process should document the limiting seas for safe operation of the craft:

.1. in normal operation at maximum operational speed the accelerations should not exceed safety level 1 in annex 3 with an average of 1 per 5-min period. The craft operating manual should include detailed description of the effects of speed reduction or change of heading to the waves in order to prevent exceedance;

.2. in the worst intended conditions, with reduced speed as necessary, the accelerations should not exceed safety level 2 in annex 3 with an average of 1 per 5-min period, nor should any other craft characteristic motion as pitch, roll and yaw exceed levels that could impede the safety of passengers. In worst intended conditions, with reduced speed as necessary, craft should be safely manoeuvrable and provide adequate stability in order that the craft can continue safe operation to the nearest place of refuge, provided caution is exercised in handling. Passengers should be required to be seated when safety level 1 in annex 3 is exceeded; and

.3. within the actual structural design load for the craft, with reduced speed and change of heading, as necessary.

3.4. Turning and manoeuvrability

The craft should be safely controllable and manoeuvrable during:

.1. hull-borne operation;

.2. operation in non-displacement mode;

.3. take-off, landing;

.4. any intermediate or transition modes, as applicable; and

.5. berthing operations, as applicable.

## 4 Effects of failures or malfunction

### 4.1 General

. The limits of safe operation, special handling procedures and any operational restrictions should be examined and developed as a result of full-scale trials conducted by simulating possible equipment failures.

. The failures to be examined should be those leading to major or more severe effects as determined from evaluation of FMEA or similar analysis.

. Failures to be examined should be agreed between the craft manufacturer and the Administration and each single failure should be examined in a progressive manner.

### 4.2 Objects of tests

. Examination of each failure should result in:

.1. determining safe limits of craft operation at the time of failure, beyond which the failure will result in degradation beyond safety level 2;

.2. determining crew member's actions, if any, to minimize or counter the effect of the failure; and

.3. determining craft or machinery restrictions to be observed to enable the craft to proceed to a place of refuge with the failure present.

### 4.3 Failures to be examined

. Equipment failures should include, but not be limited to, the following:

.1. total loss of propulsion power;

.2. total loss of lift power (for ACV and SES);

.3. total failure of control of one propulsion system;

.4. involuntary application of full propulsion thrust (positive or negative) on one system;

.5. failure of control of one directional control system;

.6. involuntary full deflection of one directional control system;

.7. failure of control of trim control system;

.8. involuntary full deflection of one trim control system element; and

.9. total loss of electrical power.

Failures should be fully representative of service conditions and should be simulated as accurately as possible in the most critical craft manoeuvre where the failure will have maximum impact.

### 4.4 "Dead ship" test

. In order to establish craft motions and direction of laying to wind and waves, for the purposes of determining the conditions of a craft evacuation, the craft should be stopped and all main machinery shut down for sufficient time that the craft's heading relative to wind and waves has stabilized. This test should be carried out on an opportunity basis to establish patterns of the design's "dead ship" behaviour under a variety of wind and sea states.



# Annex 9 - Criteria for Testing and Evaluation of Revenue and Crew Seats

## 1 Purpose and scope

. The purpose of these criteria is to provide requirements for revenue and crew seats, seat anchorages and seat accessories and their installation to minimize the possibility of occupant injury and/or disruption of egress/ingress if the craft suffers a collision.

## 2 Static seat tests

2.1. The requirements of this paragraph are applicable for crew and revenue seats in craft having a design collision load of less than 3 g.

2.2. All seats to which this paragraph applies, along with their supports and deck attachments, should be designed to withstand at least the following static forces applied in the direction of the craft:

- .1. Forward direction: a force of 2.25 kN,
- .2. After direction: a force of 1.5 kN,
- .3. Transverse direction: a force of 1.5 kN,
- .4. Vertically downward: a force of 2.25 kN, and
- .5. Vertically upward: a force of 1.5 kN.

If these forces are applied in the fore or aft direction of the seat, they should be applied horizontally to the seat back 350 mm above the seat bottom. If the forces are applied in the transverse seat direction, they should be applied horizontally to the seat bottom. Vertical upward forces should be evenly distributed to the corners of seat bottom frame. Vertical downward forces should be uniformly distributed over the seat bottom.

If a seating unit consists of more than one seating position, these forces should be applied at each seating position concurrently during the tests.

2.3. When the forces are applied to a seat, consideration should be given to the direction in which the seat is to face in the craft. For example, if the seat faces sideways, the transverse craft force would be applied fore and aft on the seat and the forward craft force would be applied transversely on the seat.

2.4. Each seating unit to be tested should be attached to the support structure similar to the manner in which it will be attached to the deck structure in the craft. Although a rigid support structure can be used for these tests, a support structure, having the same strength and stiffness as the support structure in the craft, is preferred.

2.5. The forces described in 2.2.1 to 2.2.3 should be applied to the seat through a cylindrical surface having a radius of 82 mm and a width at least equal to the width of the seat. The surface should be equipped with at least one force transducer able to measure the forces specified.

2.6. The seat should be considered acceptable if:

- .1. under the influence of the forces referred to in 2.2.1 to 2.2.3, the permanent displacement measured at the point of application of the force is not more than 400 mm;
- .2. no part of the seat, the seat mountings or the accessories become completely detached during the tests;
- .3. the seat remains firmly held, even if one or more of the anchorages is partly detached, and all of the locking systems remain locked during the whole duration of the test (adjustment and locking systems need not be operational after the tests); and

.4. rigid parts of the seat with which the occupant may come into contact should present a curved surface with a radius of at least 5 mm.

2.7. The requirements of section 3 may be used in lieu of the requirements of this section provided that the accelerations used for the tests are at least 3 g.

### 3 Dynamic seat tests

3.1. The requirements of this section are applicable for crew and revenue seats in craft having a design collision load of 3 g or greater.

3.2. All seats for which this section applies, the seat supporting structure, the attachment to the deck structure, the lap belt, if installed, and shoulder harness, if installed, should be designed to withstand the maximum acceleration force that can be imposed upon them during a design collision. Consideration should be given to the orientation of the seat relative to the acceleration force (i.e. whether the seat is forward, aft, or side facing).

3.3. The acceleration pulse to which the seat is subjected should be representative of the collision time-history of the craft. If the collision time-history is not known, or cannot be simulated, the acceleration time-history envelope shown in the figure can be used.

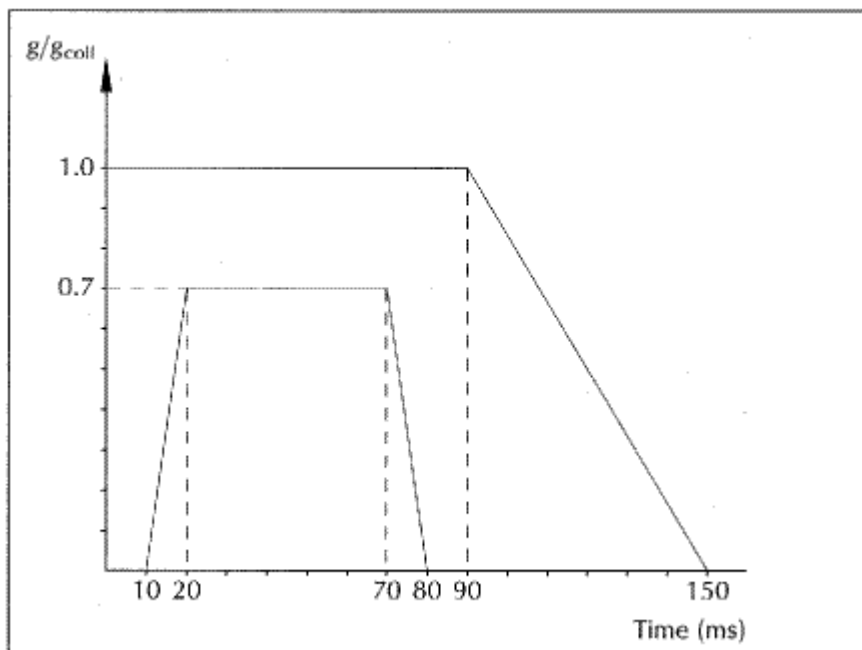

**Figure 1**

3.4. In the test frame, each seat unit and its accessories (e.g., lap belts and shoulder harnesses) should be attached to the support structure similar to the manner in which it will be attached to the deck structure in the craft. The support structure can be a rigid surface, however, a support structure having the same strength and stiffness as the support structure in the craft is preferred. Other seats and/or tables with which an occupant may come in contact during a collision should be included in the test frame in an orientation and with a method of attachment typical of that in the craft.

3.5. During the dynamic seat test, a fiftieth percentile anthropomorphic test dummy, corresponding to the Hybrid II or Hybrid III (preferred) human surrogate (unless a more advanced test dummy is available), should be placed in the seat in an upright seating position. If a typical seating unit is composed of more than one occupant seat, a test dummy should be placed in each occupant seat in the unit. The dummy, or dummies, should be secured in the seat unit in accordance with procedures of recognized national standards and be secured using only the lap belt and shoulder harness if they are installed. Tray tables and other such devices should be placed in the position that would cause the greatest potential for an occupant to become injured.

3.6. The test dummy should be instrumented and calibrated, in accordance with the requirements of a recognized national standard, so as to permit calculation of the head injury criterion, calculation of the thoracic trauma index, measurement of force in the femur, and measurement, if possible, of extension and flexion of the neck, measurement of the maximum relative pelvis acceleration, and measurement of the maximum pelvis load in the direction of the spine.

3.7. If more than one dummy is used in the tests, the dummy located in the seat having the highest potential for an occupant to be injured should be the one instrumented. The other dummy or dummies need not be instrumented.

3.8. The tests should be conducted and the instrumentation should be sampled at a rate sufficient to reliably show response of the dummy in accordance with the requirements of a recognized national standard.

3.9. The seat unit tested in accordance with the requirements of this section should be considered acceptable if:

.1. The seat unit and tables installed in the seat unit or area do not become dislodged from the supporting deck structure and do not deform in a manner that would cause the occupant to become trapped or injured.

.2. The lap belt, if installed, remains attached and on the test dummy's pelvis during the impact. The shoulder harness, if installed, remains attached and in the immediate vicinity of the test dummy's shoulder during the impact. After the impact, the release mechanisms should be operative.

.3. The following acceptability criteria are met:

.1. the head injury criterion (HIC), calculated in accordance with the formula, does not exceed 500

$$HIC = (t_2 - t_1) \left[ \frac{1}{t_2 - t_1} \int_{t_1}^{t_2} a(t) dt \right]^{2.5}$$

where:

$t_1$  and  $t_2$  are the beginning and ending times (in seconds) of the interval in which the HIC is a maximum. The term  $a(t)$  is the resultant measured acceleration in the head of the dummy in g;

.2. the thoracic trauma index (TTI), calculated in accordance with the formula, does not exceed 30 g except for periods totalling less than 3 ms

$$TTI = \frac{g_R + g_{LS}}{2}$$

or acceleration at the centre of gravity

where:

$g_R$  is the acceleration in g of either the upper or lower rib; and

$g_{LS}$  is the acceleration in g of the lower spine;

.3. the maximum pelvis acceleration does not exceed 130 g's;

.4. the maximum pelvic load does not exceed 6.7 kN measured in the axis of the spine,

.5. neck flexion does not exceed 88 Nm, if measured;

.6. neck extension does not exceed 48 Nm, if measured; and

.7. the force in the femur does not exceed 10 kN except that it cannot exceed 8 kN for periods totalling more than 20 ms.

.4. Loads on the upper torso harness straps do not exceed 7.8 kN or a total of 8.9 kN if dual straps are used.

# Annex 10 - Open Reversible Liferafts

## 1 General

1.1. All open reversible liferafts should:

- .1. be constructed with proper workmanship and materials;
- .2. not be damaged in stowage throughout the air temperature range of  $-18^{\circ}\text{C}$  to  $+65^{\circ}\text{C}$ ;
- .3. be capable of operating throughout an air temperature range of  $-18^{\circ}\text{C}$  to  $+65^{\circ}\text{C}$  and a seawater temperature range of  $-1^{\circ}\text{C}$  to  $+30^{\circ}\text{C}$
- .4. be rot-proof, corrosion-resistant and not be unduly affected by seawater, oil or fungal attack;
- .5. be stable and maintain their shape when inflated and fully laden; and
- .6. be fitted with retro-reflective material, where it will assist in detection, and in accordance with recommendation adopted by the Organization.

## 2 Construction

2.1. The open reversible liferaft should be so constructed that when it is dropped into the water in its container from a height of 10 m, the liferaft and its equipment will operate satisfactorily. If the open reversible liferaft is to be stowed at a height of more than 10 m above the waterline in the lightest seagoing condition, it should be of a type which has been satisfactorily drop-tested from at least that height.

2.2. The open reversible floating liferaft should be capable of withstanding repeated jumps on to it from a height of at least 4.5 m.

2.3. The open reversible liferaft and its fittings should be so constructed as to enable it to be towed at a speed of 3 knots in calm water when loaded with its full complement of persons and equipment, with the sea-anchor deployed.

2.4. The open reversible liferaft when fully inflated should be capable of being boarded from the water whichever way up it inflates.

2.5. The main buoyancy chamber should be divided into:

.1. not less than two separate compartments, each inflated through a nonreturn inflation valve on each compartment; and

.2. the buoyancy chambers should be so arranged that in the event of one of the compartments being damaged or failing to inflate, the intact compartment should be able to support, with positive freeboard over the open reversible liferaft's entire periphery, the number of persons which the liferaft is permitted to accommodate, each having a mass of 75 kg and seated in their normal positions.

2.6. The floor of the open reversible liferaft should be waterproof.

2.7. The open reversible liferaft should be inflated with a non-toxic gas by an inflation system complying with the requirements of regulation III/39 of the Convention. Inflation should be completed within the period of one minute at an ambient temperature of between  $18^{\circ}\text{C}$  and  $20^{\circ}\text{C}$  and within a period of three minutes at an ambient temperature of  $-18^{\circ}\text{C}$ . After inflation the open reversible liferaft should maintain its form when loaded with its full complement of persons and equipment.

2.8. Each inflatable compartment should be capable of withstanding a pressure equal to at least three times the working pressure and should be prevented from reaching a pressure exceeding twice the working pressure either by means of relief valves or by a limited gas supply. Means should be provided for fitting the topping-up pump or bellows.

2.9. The surface of the buoyancy tubes should be of non-slip material. At least 25% of these tubes should be of a highly visible colour.

2.10. The number of persons which an open reversible liferaft should be permitted to accommodate should be equal to the lesser of:

.1. the greatest whole number obtained by dividing by 0.096 the volume, measured in cubic metres of the main buoyancy tubes (which for this purpose should not include the thwarts if fitted) when inflated; or

.2. the greatest whole number obtained by dividing by 0.372 the inner horizontal cross-sectional area of the open reversible liferaft measured in square metres (which for this purpose may include the thwart or thwarts, if fitted) measured to the innermost edge of the buoyancy tubes; or

.3. the number of persons having an average mass of 75 kg, all wearing lifejackets, that can be seated inboard of the buoyancy tubes without interfering with the operation of any of the liferaft's equipment.

### 3 Open reversible liferaft fittings

3.1. Lifelines should be securely becketed around the inside and outside of the open reversible liferaft.

3.2. The open reversible liferaft should be fitted with an efficient painter of a length suitable for automatic inflation on reaching the water. For open reversible liferafts accommodating more than 30 persons an additional bowsing-in line should be fitted.

3.3. The breaking strength of the painter system including its means of attachment to the open reversible liferaft, except the weak link required by regulation III/39 of the Convention, should be:

.1. 7.5 kN for open reversible liferafts accommodating up to 8 persons;

.2. 10.0 kN for open reversible liferafts accommodating 9 to 30 persons; and

.3. 15.0 kN for open reversible liferafts accommodating more than 30 persons.

3.4. The open reversible liferaft should be fitted with at least the following number of inflated ramps to assist boarding from the sea whichever way up the raft inflates:

.1. one boarding ramp for open reversible liferafts accommodating up to 30 persons; or

.2. two boarding ramps for open reversible liferafts accommodating more than 30 persons, such boarding ramps should be 180° apart.

3.5. The open reversible liferaft should be fitted with water pockets complying with the following requirements:

.1. the cross-sectional area of the pockets should be in the shape of an isosceles triangle with the base of the triangle attached to the buoyancy tubes of the open reversible liferaft;

.2. the design should be such that the pockets fill to approximately 60% of capacity within 15 s to 25 s of deployment;

.3. the pockets attached to each buoyancy tube should normally have aggregate capacity of between 125 l and 150 l for inflatable open reversible liferafts up to and including the 10 person size;

.4. the pockets to be fitted to each buoyancy tube on liferafts certified to carry more than 10 persons should have as far as practicable an aggregate capacity of  $(12 \times N)$  litres, where N is the number of persons carried;

.5. each pocket on a buoyancy tube should be attached so that when the pocket is in the deployed position it is attached along the full length of its upper edges to, or close to, the lowest part of the lower buoyancy tube; and

.6. the pockets should be distributed symmetrically round the circumference of the liferaft with sufficient separation between each pocket to enable air to escape readily.

3.6. At least one manually controlled lamp complying with the requirements should be fitted on the upper and lower surfaces of the buoyancy tubes.

3.7. Suitable automatic drain arrangements should be provided on each side of the floor of the liferaft in the following manner:

.1. one for open reversible liferafts accommodating up to 30 persons; or

.2. two for open reversible liferafts accommodating more than 30 persons.

3.8. The equipment of every open reversible liferaft should consist of:

.1. one buoyant rescue quoit, attached to not less than 30 m of buoyant line with a breaking strength of at least 1 kN;

.2. two safety knives of the non-folding type having a buoyant handle should be fitted attached to open reversible liferaft by light lines. They should be stowed in pockets so that, irrespective of the way in which the open reversible liferaft inflates, one will be readily available on the top surface of the upper buoyancy tube in a suitable position to enable the painter to be readily cut;

.3. one buoyant bailer;

.4. two sponges;

.5. one sea anchor permanently attached to the open reversible liferaft in such a way as to be readily deployable when the open reversible liferaft inflates. The position of the sea anchor should be clearly marked on both buoyancy tubes;

.6. two buoyant paddles;

.7. one first-aid outfit in a waterproof case capable of being closed tightly after use;

.8. one whistle or equivalent sound signal;

.9. two hand flares;

.10. one waterproof electric torch suitable for Morse signalling together with one spare set of batteries and one spare bulb in a waterproof container;

.11. one repair outfit for repairing punctures in buoyancy compartments; and

.12. one topping-up pump or bellows.

3.9. The equipment specified in 3.8 is designated an HSC Pack.

3.10. Where appropriate, the equipment should be stowed in a container which, if it is not an integral part of, or permanently attached to the open reversible liferaft, should be stowed and secured to the open reversible liferaft and be capable of floating in water for at least 30 min without damage to its contents. Irrespective of whether the equipment container is an integral part of, or is permanently attached to, the open reversible liferaft, the equipment should be readily accessible irrespective of which way up the open reversible liferaft inflates. The line which secures the equipment container to the open reversible liferaft should have a breaking strength of 2 kN or a breaking strength of 3:1 based on the mass of the complete equipment pack, whichever is the greater.

## 4 Containers for open reversible inflatable liferafts

4.1. The open reversible liferafts should be packed in a container that is:

- .1. so constructed as to withstand conditions encountered at sea;
- .2. of sufficient inherent buoyancy, when packed with the liferaft and its equipment, to pull the painter from within and to operate the inflation mechanism should the craft sink; and
- .3. as far as practicable watertight, except for drain holes in the container bottom.

4.2. The container should be marked with:

- .1. maker's name or trademark;
- .2. serial number;
- .3. the number of persons it is permitted to carry;
- .4. non-SOLAS reversible;
- .5. type of emergency pack enclosed;
- .6. date when last serviced;
- .7. length of painter;
- .8. maximum permitted height of stowage above waterline (depending on drop-test height); and
- .9. launching instructions.

## 5 Markings on open reversible inflatable liferafts

. The open reversible liferafts should be marked with:

- .1. Maker's name or trademark;
- .2. serial number;
- .3. date of manufacture (month and year);
- .4. name and place of service station where it was last serviced; and
- .5. number of persons, it is permitted to accommodate on the top of each buoyancy tube, in characters not less than 100 mm in height and of a colour contrasting with that of the tube.

## 6 Instructions and information

. Instructions and information required for inclusion in the craft's training manual and in the instructions for on-board maintenance should be in a form suitable for inclusion in such training manual and instructions for on-board maintenance. Instructions and information should be in a clear and concise form and should include, as appropriate, the following:

- .1. general description of the open reversible liferaft and its equipment;
- .2. installation arrangements;

.3. operational instructions including use of associated survival equipment; and

.4. servicing requirements. ``